



Rogue Valley Transportation District

REQUEST FOR PROPOSALS

Design and Installation CNG Compressor Skid Replacement Project

RFP NO. CNGCOMP26

Published June 5, 2026
Rogue Valley Transportation District
Attention: Nick Black
101 S Front St
Medford, OR 97501

Responses are due: **June 30, 2026 5:00pm (PST)**

Table of Contents

- **Section 1: Schedule of Events**
- **Section 2: General Provisions and Scope of Work**
- **Section 3: Inspection, Testing and Acceptance**
- **Section 4: Required Experience**
- **Section 5: Products**
- **Section 6: CNG Compressor Skid**
- **Section 7: CNG Compressors**
- **Section 8: Skid Mounted Pressure Vessels**
- **Section 9: Compressor Prime Movers**
- **Section 10: Motor Starter Panel**
- **Section 11: Instruments and Controls For Compressor System**
- **Section 12: Emergency Shutdown System**
- **Section 13: Execution**
- **Section 14: Adjusting, Balancing and Testing**
- **Section 15: Evaluation & RVTD's Rights**
- **Section 16: Required Forms**
- **Section 17: Federally Required And Other Model Contract Clauses**
- **Section 18: RVTD Campus Layout**
- **Section 19: Current Fueling infrastructure Photos**
- **Section 20: Existing Fueling Station As-Builts**

HISTORY AND CURRENT FACILITIES

The Rogue Valley Transportation District (RVTD) has been in operation since 1975. RVTD's current fueling system was installed in 2012 and has exceeded its useful life. RVTD operates a fleet of CNG fueled transit buses and relies on having CNG available onsite to provide public transit to our community. The goal of this project is to provide RVTD with reliable and efficient onsite CNG fueling capabilities. The successful proposer will design the upgrades using existing equipment where feasible.

RVTD operates a fleet of 31 CNG fueled buses, consuming approximately 200,000 GGE of CNG annually. Our current fueling equipment consists of two Knox Western CNG compressors mounted on a single enclosed skid. The current specifications are as follows.

1. Existing Equipment/Infrastructure

- 460v, 800 Amp feed available
- Twin 4 stage Compressors housed in single skid, twin 250hp, 1200rpm motors
- Gas supply 55psi inlet pressure -880CF/SEC load rate
- Current compressors supply 307 ft³/m of CNG flow at 1200rpm. They were originally designed as 1800rpm compressors.
- Two fast fill dispensers. One dispenser is equipped with a remote fill hose.
- One natural gas dryer
- 4 gas storage vessels

SECTION 1.0 SCHEDULE OF EVENTS

- **RFP Release Date..... June 5, 2026**
- **Optional Pre-proposal Conference..... June 15, 2026**

This meeting will cover the proposed location for the CNG fueling facility and the technical aspects of the RFP and required attachments. PROPOSERS will be given the opportunity to ask any questions or concerns they may have. In-person attendance is not required.

- **Written Questions/Clarifications deadline... June 18, 2026**
- **Answers to Proposers..... June 23, 2026**
- **Proposals Due..... June 30, 2026**

Proposers shall submit one (1) signed original proposal, four (4) copies of their proposals and one digital copy on a thumb drive. Proposals can be mailed via certified mail or hand delivered to:

**RVTD
101 South Front St.
Medford, OR 97501
Attn: RFP #CNGCOMP26**

Proposals are Due no later than 5:00pm PST

Late RFP's will be returned un-opened to the proposer. As this is an RFP and not an Invitation for Bids (IFB), the opening of the proposals will not be a public meeting.

- **Meeting with Proposers
in Competitive Range July 27-28, 2026**
- **Best and Final Offers Due..... August 13, 2026**
- **Contract Intent to Award..... August 19, 2026**
- **Contract Award..... August 26, 2026**
- **Expected Notice to Proceed..... September 14, 2026**
- **Substantial Completion Met..... August 1, 2027**

SECTION 2.0 GENERAL PROVISIONS AND SCOPE OF WORK

2.1 Introduction

The request for proposals (RFP) is issued by Rogue Valley Transportation District (RVTD) to seek proposals from qualified bidders for the design, construction and installation of two fast fill natural gas compressors housed within one skid, and two CNG dispensers and a replacement gas dryer rated for a minimum of 300 psi gas pressure. RVTD's current CNG equipment operates with a natural gas inlet pressure of 55psi. RVTD will be upgrading our gas supply feed in conjunction with the new equipment installation. The new equipment will have available natural gas inlet pressure of 300psi. RVTD fast fills its CNG fueled bus fleet nightly.

The new CNG compressor skid will be placed on the existing footprint of the current compressor skid located at 3150 Crater Lake Ave, Medford OR 97504. The successful proposer will design the upgrades using existing equipment where feasible.

Downtime of our existing CNG equipment is a great concern to RVTD. The successful proposer must propose a temporary CNG fueling solution during the duration of installation.

Proposers must meet the qualifications of the project and have experience designing and installing new or replacement CNG compressor skids. The contractor shall be responsible for all work associated with the project including any design, permitting, approvals, equipment/material sourcing, construction/installation, and commissioning.

This procurement is a Federal Transit Administration (FTA) funded project and therefore Proposers are hereby bound by all applicable federal, state, and local laws and regulations, and certifications. In accordance with the Civil Rights Act of 1964, Proposers are hereby notified that Disadvantaged Business Enterprises (DBEs) and Small Business Enterprises (SBE) are encouraged to submit Proposals and will be afforded full opportunity to submit and participate in this request. No extra points will be awarded during evaluation to any proposals that show DBE/SBE participation.

2.2 Scope of Work

Rogue Valley Transportation District currently has a transit fleet of 31 CNG buses. To meet the current and future needs of the CNG fleet, the RVTD is procuring the design and construction/installation of new CNG compressors, PLC system, natural gas dryer and CNG dispensers to reliably support the CNG bus fleet.

RVTD anticipates the design services to begin within 6 months of award. Contractor has an 8-week window from "groundbreaking to commissioning". This 8-week window does not include the installation of the temporary fueling method, but rather at the start of existing equipment removal. Full system testing shall begin no later than June 30, 2027. Commissioning of equipment, considered substantial completion, shall occur no later than August 1, 2027.

RVTD seeks the following summary of work to be performed.

1. Design a replacement CNG compressor skid assembly using existing equipment where feasible. Design must be approved by RVTD prior to the commencement of other tasks.
2. Provide a CNG fueling solution so that RVTD will experience no downtime during the project.

3. Remove the existing CNG compressor skid and replace with two (2) new CNG compressors housed in one skid that closely matches the existing CNG compressor 1 & 2 skid size and utility locations.
4. New CNG compressors should be designed and engineered in a way to closely match the existing power and gas plumbing found on RVTD's current compressor site.
5. Make all associated mechanical connections as required.
6. Make all associated electrical, electronic and controls connections as required.
7. Upgrade current PLC systems to modern equipment compatible with the new CNG compressors.
8. Remove existing natural gas dryer and install a new unit compatible with a 300psi inlet pressure.
9. Conduct commissioning and startup services as required.
10. Replace the two (2) existing 3600psi Kraus Global CNG dispensers with new dispensers compatible with delivering the specified gas flow requirements and compatible with a 3-stage storage tank system.
11. Proposed CNG fueling equipment must meet a 95 percent minimum up time for reliability.
12. Provide a 5-year preventative maintenance and repair contract along with 2, optional 5-year preventative maintenance and repair contract extensions. Provide an option for a two-year extended full coverage warranty that would include replacement parts, diagnostics and repair labor costs. Preventative maintenance shall be performed in accordance with manufacturer recommendations and coordinated to minimize disruption to RVTD fueling operations.

2.3.1 Transition and Implementation

The transition process to remove the existing CNG compressor and related fueling equipment and install new CNG compressor skid and related equipment will involve an assessment of current equipment, existing infrastructure, and staff training to ensure minimal disruption to service operations.

1. Transition from current CNG fueling equipment.
 - A. System Implementation Plan: The Proposer shall provide a step-by-step process in the proposal for removing old equipment and installation of new equipment. This plan will include key milestones, responsibilities, resource allocation, and timelines for each phase of implementation. It will also detail the installation of temporary fueling equipment and estimated downtime of a permanent CNG fueling station.
 - B. Fueling Equipment Removal and Installation Plan: The Proposer shall supply a plan detailing technical requirements, utilized removal/installation equipment, timelines and detailed specifications of new fueling equipment tie ins to existing infrastructure. This includes the CNG compressor skid, PLC systems and CNG fueling dispensers.
2. Removal, Installation and training of CNG fueling equipment will be coordinated with the selected CONTRACTOR and RVTD's Maintenance Manager or designee, when applicable, to ensure smooth deployment of this project. Training sessions will be conducted for RVTD Maintenance staff to familiarize them with the new CNG fueling equipment features, functionalities, and best practices for efficient use.
 - A. Installation Schedule: The Proposer's installation schedule will detail the timeline and sequencing

of activities related to equipment removal and installation and training sessions. The Proposer shall indicate which activities will take place in person versus virtual. Key milestones and deadlines will be clearly defined to ensure alignment with RVTDs' needs.

- B. Testing Requirements (testing environment): Proposer shall include details for functional testing, usability testing, integration testing, and performance testing to identify and address any issues or defects before full deployment and temporary fueling system removal.
- C. Equipment Commissioning: Proposer shall include details for the commissioning of the new and modified CNG equipment. Include the process, sequencing and any quality assurance methods that verifies the new or modified machinery and systems are designed, installed, tested, and operating according to the owner's requirements. This serves as the bridge between installation and full operational handover and once complete will be considered substantial completion.
- D. Training Plan: Proposer shall provide a detailed training plan in the proposal which will be used to educate RVTD staff on how to effectively utilize new fueling equipment in their daily operations. Training sessions will cover daily use and inspection of equipment, functionalities, and equipment safety topics. The Proposer is expected to organize the materials to align with the equipment end users, mechanics, fuelers, etc.

2.4 WARRANTY, SERVICE RESPONSE AND SYSTEM SUPPORT REQUIREMENTS

A. General Requirements

The Contractor shall provide comprehensive warranty support, preventive maintenance services, emergency repair services, technical support, and operational assistance for all Contractor-supplied equipment, components, controls, dispensers, compressors, PLC systems, instrumentation, and associated appurtenances furnished under this Contract.

The Contractor shall maintain sufficient staffing, technical capability, replacement parts availability, and service resources necessary to support continuous operation of RVTD's CNG fueling facility.

The Contractor shall provide 24-hour emergency technical support coverage for the duration of the warranty period and any contracted maintenance or service agreement periods.

B. Definitions

1. Critical Fueling System Failure - A Critical Fueling System Failure shall be defined as any condition that:
 - Prevents normal fueling operations;
 - Prevents RVTD from fueling sufficient vehicles to maintain transit service operations;
 - Disables all compressors;
 - Reduces fueling capacity below operational fleet requirements;
 - Disables all fueling dispensers;
 - Causes activation of the emergency shutdown system;
 - Results in unsafe operating condition;
 - Results in uncontrolled gas leakage;
 - Or otherwise renders the fueling facility substantially inoperable.

2. Major System Failure - A Major System Failure shall be defined as any non-critical condition that:
 - Reduces system redundancy;
 - Disables one compressor while another compressor remains operational;
 - Reduces fueling performance;
 - Causes recurring operational alarms;
 - Or impacts system reliability without fully disabling fueling operations.

 3. Minor System Failure- A Minor System Failure shall be defined as any condition that does not materially impact fueling operations or system safety, including nuisance alarms, indicator failures, reporting issues, or non-critical instrumentation faults.
-

C. Required Service Response Times

1. Critical Fueling System Failure

The Contractor shall:

- Provide qualified remote technical response within one (1) hour of notification;
- Provide qualified onsite technician response within twelve (12) hours of notification;
- Maintain continuous repair efforts until fueling capability is restored.

If a Critical Fueling System Failure cannot be permanently corrected within four business days of equipment failure, (96) hours, the Contractor shall provide a temporary fueling solution acceptable to RVTD until permanent repairs are completed.

2. Major System Failure

The Contractor shall:

- Provide remote technical response within two (2) hours of notification;
- Provide onsite technician response within twenty-four (24) hours of notification.

3. Minor System Failure

The Contractor shall:

- Respond within one (1) business day;
 - Coordinate repair scheduling with RVTD maintenance staff.
-

D. Temporary Fueling Support Due to System Failure

If fueling capability is interrupted due to Contractor-supplied equipment failure for a duration of five business days or longer during the warranty period, the Contractor shall provide temporary fueling support as necessary to maintain RVTD fleet operations.

Temporary fueling support may include:

- Mobile fueling equipment;
- Tube trailer fueling systems;

- Temporary compressors;
- Temporary dispensers;
- Or other Owner-approved temporary fueling solutions.

The Contractor shall be responsible for all labor, transportation, setup, operational support, and removal associated with temporary fueling systems unless otherwise approved in writing by RVTD.

E. Preventive Maintenance Requirements

The Contractor shall provide preventive maintenance services in accordance with manufacturer recommendations and industry best practices.

Preventive maintenance activities shall include, at minimum:

- Inspection of compressors and prime movers;
- Inspection and testing of safety systems;
- Oil analysis and replacement;
- Filter replacement;
- Instrument calibration;
- PLC and controls diagnostics;
- Methane detection testing;
- Vibration monitoring;
- Valve inspection and testing;
- Dryer maintenance;
- Dispenser inspection and calibration.

Scheduled maintenance activities resulting in fueling downtime shall be coordinated with RVTD at least seven (7) calendar days in advance unless emergency conditions exist.

Preventive maintenance activities shall be scheduled to minimize disruption to RVTD fueling operations.

F. Replacement Parts Availability

The Contractor shall maintain access to critical replacement parts necessary to restore fueling operations in a timely manner.

Critical replacement parts shall include, at minimum:

- PLC and control components;
- Pressure transducers and sensors;
- Methane detection components;
- Starter and motor control components;
- Solenoid valves and actuators;
- Compressor service components;
- Dispenser communication components;
- HMI display components;
- Electrical relays and protection devices.

The Contractor shall identify anticipated lead times for major replacement components within the proposal submission.

G. Uptime Requirements

The Contractor shall design, install, and support the fueling system to achieve a minimum operational uptime of ninety-five percent (95%).

System up time shall be calculated on a rolling twelve-month basis.

Uptime calculations shall exclude:

- Utility electrical outages;
- Utility natural gas service interruptions;
- Force majeure events;
- Owner-directed shutdowns;
- Damage caused by third parties;
- Scheduled preventive maintenance approved by RVTD.

Downtime shall include all unscheduled failures of Contractor-supplied equipment that reduce fueling capability below required operational performance.

RVTD reserves the right to request uptime documentation and maintenance records at any time during the warranty or service agreement period.

H. Service Documentation

The Contractor shall provide written service reports following all preventive maintenance activities and emergency service calls.

Service reports shall include:

- Date and time of notification;
- Technician arrival time;
- Description of issue;
- Root cause analysis;
- Corrective actions performed;
- Parts replaced;
- System testing performed;
- Return-to-service time;
- Recommendations for future corrective action, if applicable.

Service reports shall be submitted to RVTD within five (5) business days following completion of service activities.

I. Escalation and Support Contacts

The Contractor shall provide an escalation matrix identifying:

- Primary technical support contacts;
- Secondary technical support contacts;

- Emergency after-hours contacts;
- Service management contacts;
- Parts procurement contacts;
- Warranty administration contacts.

The escalation matrix shall be updated whenever staffing or contact information changes.

J. Warranty Coverage

The Contractor shall provide a minimum warranty period of two (2) years from the date of final acceptance unless otherwise specified elsewhere in this Contract.

Warranty coverage shall include:

- Parts;
- Labor;
- Travel expenses;
- Diagnostic services;
- Software and firmware support;
- Repair or replacement of defective equipment;
- Recommissioning following repairs.

Warranty exclusions shall be clearly identified within the proposal submission.

SECTION 3.0 INSPECTION, TESTING AND ACCEPTANCE

1. General. The Contractor shall be responsible for proving to the satisfaction of the Owner that the minimum specifications for the Equipment and installation work, as described herein, have been met. The Owner will require the execution of various inspections and tests, including documentation thereof, prior to accepting the Equipment as complete and in compliance with these specifications. Such inspections and tests shall be based on recommendations by the Contractor, as well as the CNG skid manufacturer and manufacturer/vendors of various components and systems of the work. If the Owner determines that such recommended inspections and tests are not adequate, the Owner shall require additional inspections and tests as needed. Inspections, witnessing of tests, or waiving of any such procedure by the Owner shall not release the Contractor, or its designees from full responsibility for compliance with equipment, material and functional requirements according to the project specifications.
2. Requirements. Contractor shall supply the Owner all recommended acceptance and testing procedures of main vendor and other vendor in-process manufacturing, factory pre-delivery functional demonstration, installation and start-up for at least the components and systems described as:
 - A-Replacement Skid mounted CNG compressors
 - B-Starter-motor system for new CNG Compressor skids
 - C-Controls/ I/O modules & PLC system for CNG compressors
 - D-Two new CNG dispensers.
 - E-All required valving.
 - F-Replacement natural gas dryer
3. Contractor shall also provide test equipment, material and labor to conduct on-site testing and start-up procedures. Such procedures shall be provided to the Owner for each of the above components and systems. All tests shall be witnessed by the Owner to determine compliance with specifications
4. Documentation and Notification. Recommended procedures for compressor skid manufacturer acceptance and testing shall be submitted in writing to the Owner not more than thirty days after contract award, or no later than two weeks prior to start of tests, whichever occurs first. Complete compressor skids must be accompanied by factory test, inspection reports and manufacturer warranties at or before delivery to site. Notification for such procedures will be witnessed by the Owner shall be given at least 48 hours prior to start of construction test/inspection, and at least two weeks prior to factory test, unless otherwise agreed to by manufacturer. Additionally, the Owner will give notice of required modifications to inspections and tests originally recommended, if any, at this time.
5. In-Process Manufacturing Inspections. Included shall be recommendations for inspections and tests, if any, to be performed at 50-percent completion, and again at 100-percent completion, of compressor-skid manufacture/assembly at compressor skid manufacturer's site. The purpose of inspections shall be to confirm schedule and design compliance, and at 100-percent complete inspection and testing, for functional verification of all relevant components and systems.
6. Criteria. All design performance pass/fail criteria shall be as specified in these specifications and set of drawings.

7. Acceptance. Owner will only accept facility as complete after Contractor provides compliance with the requirements as specified in this RFP.
8. RVTD shall not be under any obligations for payment for any pre-contractual expenses. Pre-contractual expenses are defined as expenses incurred by the proposer include, but are not limited to:
 1. Prepare and submit a proposal in response to this RFP;
 2. Negotiate any matter related to this proposal; and/or
 3. Any other expenses incurred by Proposer prior to date of award.

SECTION 4.0 Required Experience

- A. General CNG Experience.
 1. Contractor or subcontractors shall have applicable Oregon licenses.
- B. Contractor shall have experience designing and installing new or replacement CNG-compressor skids with a compressor rating of at least 250 HP into existing CNG facilities. Provide references for at least three such projects completed within the last ten years.
- C. Proposal must list qualifications and information for the team positions used on this project.
- D. Reference Requirements. For each referenced project, please provide the following information:
 1. Owner (organization or company)
 2. Location or site name
 3. City, State of facility
 4. Year completed
 5. Reference person knowledgeable of the project, including name, title, email address and phone number

The following sections 5.0 - 13.0 describe RVTD's preferences for equipment specifications. The successful Contractor may propose equivalent equipment, or alternatives that are approved by RVTD. Equivalent or alternative equipment shall be proposed during the Design phase with appropriate documentation to the satisfaction of RVTD.

SECTION 5.0 Products

- A. **New Equipment.** Equipment to be supplied by the Contractor shall be new and shall include all components and systems necessary to operate the respective system or component, compressors, prime movers, gas coolers, CNG-flow control systems, blowdown receivers, filters, safety systems, skid, frame and enclosure, and other related components and systems as described herein.
- B. **Pressure Ratings.** All piping, tubing, unions, vessels, valves, filter bodies and appurtenances shall have a manufacturer's rated normal working pressure that is equal to or above its respective normal duty pressure, with a burst-safety factor as specified by either ASME B31.3, or the ASME Boiler and Pressure Vessel Code, as appropriate. Such ratings shall be indicated on component and material submittals to be approved by the Owner.
- C. **Electrical Classifications.** All electrical and electronic components shall be installed and configured appropriately for their respective service conditions and locations. All such installations shall comply with NFPA 70 standards for Class I, Group D, Division 1, and as stipulated in Table 8.4.2.9 of NFPA 52, 2013, or other requirements as called for by authorities having jurisdiction.
- D. **Material Compatibility.** Contractor shall be responsible for providing and installing components and materials throughout the entire work that are compatible with, and do not adversely react with other component or material that could be expected to come in contact during normal operation.
- E. **Ball Valves.** All ball valves shall use 3-piece construction. Ball valves smaller than NPS 2 shall include bodies, balls and stems fabricated from 304 or 316 stainless steel and shall have a listed MAWP of not less than the highest service pressure normally existing in the process segment where it will be located. Ball valves in sizes NPS 2, or larger, may have carbon steel bodies, but otherwise shall otherwise meet the above specification for ball valves smaller than NPS 2. Actuated ball valves shall use pneumatic operators powered by a common control-air system. Actuators driven by electric motors or regulated CNG are not allowed.
- F. **Operating Environment.** All equipment, components, materials, displays and systems provided shall be designed for normal operation in an un-shaded environment with ambient temperatures ranging between 10°F and 120°F, unless explicitly excepted elsewhere in this specification section.
- G. **Phasing.** Equipment contractor to provide equipment phasing plan for removal and replacement. Contractors shall include a phasing plan into their project schedule. Contractor shall provide temporary fueling capability to maintain bus service continuity during the duration of construction. Temporary fueling must be capable of producing a minimum of 150 CFM gas flow.

SECTION 6.0 CNG Compressor Skid

- A. General. Two CNG compressors mounted within a single skid assembly shall be provided. The compressor skid shall be intended for use with natural gas and shall have a minimum discharge capacity of 460 ft³/m at 4500 PSIG, based on a suction-supply pressure of 300 PSIG at skid inlet. The new compressors shall be piped, valved and wired so they will operate independently, or in parallel operation.
- B. ESD Buttons. One ESD button shall be located outside the skid enclosure near a door.
- C. Oil 'Day' Tank. The compressor skid shall include an oil supply tank, with a minimum capacity of 10 gallons, piped to supply makeup compressor oil to the compressor sump. Tank systems shall include a low-level switch, which shall announce at its respective compressor control panel, as well as a sight glass. Sight glass shall be permanently
- D. Enclosure. Skids shall be enclosed in a weather-resistant rain-tight lockable enclosure. All enclosure doors and panels shall be removable to facilitate servicing. The enclosure shall accommodate walking room around compressors and drives within enclosure. The enclosure roof shall be designed and constructed to support a load of two feet of snow at 50% water content.
- H. Enclosure Accessories.
 - 1. Doors. Doors may be of either swing out, sliding, and/or rollup type, shall be lockable and shall include a means to open at least one door from the inside, even if locked.
 - 2. Interior Lighting. Two luminaries with (3) LED lamps each and controlled by a common manual switch shall be mounted inside each enclosure, evenly distributed within the main enclosure-interior area.
 - 3. Methane Detection. Single point-type infrared methane sensors shall be installed within 6" of the CNG-skid ceiling and shall interface with the skid controller. Detection of 20% LFL methane shall announce an alarm at the control panel. Detection of 50% LFL methane shall announce an alarm at the control panel and shut down the compressor system, in the same manner as activation of the ESD circuit.
 - 4. Sound Attenuation. Enclosure shall provide sound-attenuation features, including double-wall construction and sound-attenuated louvers for cooler air intake and exhaust. Sound pressure level produced by the compressor skid shall not exceed 79 dB, A-weighted, at any point farther than 15 feet from the skid enclosure. The sound pressure level shall not exceed 7dB(A) above ambient sound level at nearest property line.
 - 5. Ventilation. Provide a 600-CFM ventilation fan with adjustable temperature switch, initially set to 95°F. Include manual-override with 4-hour timer switch. Fan shall be ACMA type-A spark proof.
 - 6. Area Classification. Within the skid, all motors, switches, fixtures, panels or electrical devices of any type shall be listed for Division 1, Group D, Class 1 hazardous locations. Conduits shall also be appropriately listed and shall include seal off as required by NEC.

SECTION 7.0 CNG Compressors

- A. General. CNG compressors shall be reciprocating, fully lubricated, and horizontally opposed, with three or four stages of compression. Each stage of compression shall have gas-to-air after-cooling. Cooler discharge temperature in any stage shall not exceed 20°F approach of the ambient temperature, up to an ambient temperature of 120°F, in the planned un-shaded outdoor installation.
- B. Required Capacity. The compressor skid shall be sized to produce not less than 460 ft³/m of CNG at a discharge pressure of 4500 PSIG during simultaneous operation. This capacity is conditional on a design skid-inlet pressure of 300 PSIG with a 880CF/SEC load rate. The design capacity shall also allow for all pressure drops through filters, pulsation bottles, interstage devices, dryer, coolers and piping from the inlet flange to the discharge-tubing connection on the skid. RVTB requests, but does not require that these capacity specifications can be met with the compressors operating at 1200rpm.
- C. Compressor Size. The compressor frames shall be furnished with cylinders which, when operating at design operating condition(s), shall, as far as practical, load the drive motor to its full design load.
- D. Compressor Size. The compressor frames shall be furnished with cylinders which, when operating at design operating condition(s), shall, as far as practical, load the drive motor to its full design load.
- E. Accessories. The compressor shall be provided with a direct-drive assembly, interstage and discharge coalescers, and interstage and after-cooling. Each compressor should be designed for automatic starting, unloading and captured blowdown and equipped with a fail-closed inlet valve, discharge check valve, suction flex line, suction particulate filter, and discharge coalescing filter. Fail-closed inlet valve shall be actuated by the programmable controller.
- F. Recirculation. The compressors and control panel shall include a recirculation mode, where the suction-supply valves close, the blowdown-unloader valve opens, and the compressor continues to run. Recirculation mode shall begin after the buffer storage is fully replenished and no dispenser demand exists. Compressor(s) shall shut down after 5 minutes of continuous recirculation. Recirculation duration shall be user adjustable at the PLC / controller.
- G. Warmup and cooldown. The compressors and controller shall facilitate compressor warmup upon startup, and cooldown after recirculation period with no CNG demand during assigned recirculation period.
- H. Compressor Lubrication System. Compressor-cylinder action shall be force-oil- lubricated and shall include an electric motor-driven pre-lube pump.
 - 1. Lubricating Oil Carryover. Net carryover of lubricating oil from the compressor crankcases through to the dispensers shall be no greater than 0.5 pounds of oil per million SCF of compressed natural gas, equal to 11 PPM in mass. Net carryover shall not include oil drained or recovered from the blowdown receiver and coalescers.
 - 2. Piston Rings. All compressor piston rings shall be either ferrous or synthetic, subject to be reviewed and approved in submittals provided to the Owner.
 - 3. Oil. Compressor-lube oil for both crankcase lubrication and cylinder lubrication shall be a diester-type synthetic oil, as approved by the compressor manufacturer.

- I. Compressor Crankcase Ventilation. Each compressor shall be equipped with means to prevent accumulation of combustible gases in the crankcase. Vent exhaust shall be directed to a safe location and shall be protected from rain and debris by a rain cap or similar.
- J. Interstage Coalescing. Each stage shall include oil coalescing downstream of cooler outlet for that stage, or other method of interstage oil removal as approved by the Owner. Coalescing filters shall include automatic drainage to the compressor's recovery vessel.
- K. Loadings. Compressor, drive motor and auxiliary equipment shall be designed and constructed for operation under full load at normal operating conditions.
- L. Pressure Rating for Controls. All gas controls shall have a pressure rating equal to or greater than the maximum pressure to which they will be subjected during normal operation of the compressors.
- M. Appurtenance. Each compressor stage shall include a surge chamber sufficient in capacity to adequately dampen the effects of compressor pulsation on adjacent components. The first stage inlet shall include a flexible inlet pipe section to protect against vibration and movement of the compressor vs. the suction-supply piping. The compressor discharge line shall be protected by check valve(s).
- N. Alignment. Compressor and prime mover alignment shall be set in the factory using a commercial laser alignment system, (e.g., Hamar Laser). Laser alignment shall verify rigidity of the motor mount (avoid excessive soft-foot alignment), and parallelism of the axes of rotation between the motor and compressor crankshaft prior to shipment. Alignment shall be mechanically field verified to factory tolerance following completion of all anchor connections but prior to any bump-over or startup on site.
- O. Design Conditions. The compressor system shall be capable of operating within the full range of conditions specified in paragraphs 1-4 below. Values listed as 'design' shall be used for sizing the compressors with respect to specified flow rate. The values listed below supersede all other like values listed elsewhere in the specification.
 - 1. Suction Pressure. MSA outlet pressure post regulator will average 300 PSIG. The design pressure loss across the dryer and piping between the MSA and compressor inlet shall be 5 PSI, and the design pressure at the compressor-skid inlet flange shall be 300 PSIG.
 - 2. Elevation. The design basis for site elevation is 1350 feet above mean sea level.
 - 3. Ambient Temperature. The ambient temperature will range from 15°F to 120°F, with a local annual average temperature of 57°F.
- P. Approved Products. RVTD shall have the right to approve all CNG compressor skid models.

SECTION 8.0 Skid Mounted Pressure Vessels

- A. Stamping. All vessels requiring ASME stamping shall also be stamped with the following:
1. MAWP.
 2. The water volume of the vessel.
 3. Gas storage content in SCF at the MAWP.
- B. Suction Filter. (1) suction particulate filter upstream of the first stage compressor inlet shall be included.
1. Specification. This filter shall eliminate all suction gas particles (liquid and solids) with a diameter of 50 microns or greater. The filter shall be adequately sized for the maximum compressor throughput. The filter body design pressure shall not be less than the blowdown receiver relief valve set pressure.
 2. Ancillary Equipment. A drain with manual valve and differential pressure gauges shall be provided with this filter.
- C. Pulsation/Volume Bottles. Pulsation bottles sufficient in capacity to adequately dampen the effects of compressor pulsation on adjacent components shall be included in the following locations: upstream of the first-stage inlet; downstream of final-stage discharge.
1. Compliance. Design of compressor system shall comply with the guidelines of the Compressed Air and Gas Handbook, Fifth Edition, Chapter 10, published by the Compressed Air and Gas Institute, so as to minimize the effects of harmonics and pulsation. Pressure curves in Handbook (Figure 10.50, approximate bottle sizing chart) shall be extrapolated to pertinent working pressures of the relevant compression stages and systems.
 2. Drains. Pulsation bottles shall be equipped with drains.
- D. Interstage Oil Removal. Interstage coalescer downstream of each oil-lubricated cylinder between the interstage coolers and next-stage compressor inlet shall be provided.
1. Size. Separators shall be housed in a Parker J4 housing at minimum and shall be designed to eliminate 95 percent of entrained liquids and handle liquid accumulation, which may result from 12 hours of continuous compressor operation.
 2. Drains. Drains shall be a minimum 1/4-inch tube or 3/8-inch pipe and be fitted with a matching check valve. A pneumatically actuated valve shall be provided to allow liquid blowdown to the blowdown receiver vessel. Drain lines and the actuated valve shall be sized to handle compressor idling gas volumes.
- E. Two-Stage Discharge-Coalescing Filtration. Both pre-coalescer and coalescer filters shall be housed in a Parker J6 housing at minimum and shall be located immediately downstream of the final stage aftercooler of the compressor.
1. Specification. Coalescer filter discharge shall contain no more oil or other liquid hydrocarbons, exclusive of non-condensable, than 11 parts per million on a mass basis. The filters shall be sized for the maximum compressor gas flow rate over

- gas pressures ranging from 2000 to 4500 PSIG so that pressure drop does not exceed 0.5%. The first filter shall use a Parker Hannifin grade-4 coalescer element and the second filter shall use a Parker Hannifin grade-10 coalescer element.
2. Drains. The filter(s) shall have an automatic liquids purge to the blowdown receiver. The coalescing filter shall have an actuated valve which opens upon compressor shutdown and/or regular intervals of compressor runtime.
- F. Blowdown Receivers. Equip each compressor skid assembly with blowdown receiver(s) of adequate capacity and pressure rating for the normal operation of the compressor. The receiver system shall capture all gas bled from the compressor and interstage filter vessels during blowdown.
- G. Connections. The blowdown receiver(s) shall have the following connections:
1. Condensate drain. A 1/2-inch ball valve and drain port shall be provided in a readily accessible location for manual draining of liquids accumulation in the blowdown receiver.
 2. Interstage separator blowdown. A manual ball valve shall be provided to isolate the blowdown receiver from the actuated blowdown valve, to facilitate servicing of the blowdown piping, without the need to depressurize the receiver.
 3. Gas connection to compressor suction upstream of suction filter.

SECTION 9.0 Compressor Prime Movers

- A. General. Each gas compressor prime mover shall be a 460V AC, 60 Hz, 3-phase squirrel cage induction motor. Prime movers shall be totally enclosed and fan-cooled (TEFC), having a minimum continuous rating of 250 HP (base specification), with a 1.15 service factor. Prime movers shall be designed, constructed and tested in accordance with NEMA Standard MG1-1998. Motors shall also comply with the applicable portions of the Energy Policy Act of 1992, and meet NEMA Premium Efficiency design and performance standards.
- B. Ratings. Prime movers shall be rated for continuous duty at 60 HZ, single voltage with across-the-line full voltage start at 460 VAC. Prime movers shall have a 1.15 service factor. Torque characteristic shall be NEMA Design B. Motors shall have 4 poles, and a full load rated speed of 1,785 RPM. Motors shall be listed for use in Group D, Class 1, Division 2 hazardous atmospheres.
- C. Service Conditions. Motors shall be suitable for continuous duty operation without derating under the following service conditions:
1. Exposure to ambient temperatures from 0°F to 120°F, plus temperature rise resulting from friction, compression and normal system operation.
 2. Exposure to altitudes up to 1341 feet ASL.
 3. Electrical Design. Motor efficiency shall be evaluated in accordance with IEEE standard 112-1991, Subclause 6.4, Method B. The nominal efficiency, 3/4-load efficiency and guaranteed minimum efficiency shall be stamped on the motor's nameplate.

- D. **Motor Insulation.** Motor insulation shall be a non-hygroscopic, chemical and humidity resistant system. The minimum thermal rating of the system shall be Class F, as defined in NEMA MG1-1998. The stator windings shall meet or exceed NEMA MG1-1998, Part 31. Stator shall be double dipped and baked in varnish to form a heavy build that exceeds the test criteria of moisture resistance per NEMA MG-1. When operated at rated horsepower, voltage and frequency, the temperature rise of the stator winding shall not exceed 80°C, when measured by winding resistance. Motor insulation shall be designed and tested to withstand 2000 Volt transients without premature motor failure, and have no cable limitations in motor application.
- E. **Service Factor.** Motors shall be rated for a 1.15 service factor on sine wave power in a 40°C ambient temperature.
- F. **Mechanical Design.** Motor shall be totally enclosed and fan cooled (TEFC). Motor bearings have a degree of protection of IP54, from moisture and foreign material. Motors shall be equipped with ball bearings or roller bearings. Ball bearings shall be the same size on both ends. Bearings shall be re-greaseable without disassembling the fan or fan cover and provide for the elimination of purged grease through fittings extending beyond the fan cover. Inner bearing caps shall be provided for bearing retention and to prevent harmful amounts of lubricant from entering the motor interior. For direct-coupled motors, stabilized bearing temperature shall not exceed a temperature rise of 45°C, as measured by a thermocouple on the surface of the bearing house.
1. Bearings shall provide for an L-10 life of at least 26,000 hours per ANSI/AFBMA 9-1990, based on NEMA belting application limits per NEMA MG1-1993, section 14.41. The insulation system and motor leads shall be compatible with mineral oil.
 2. Condensation drain holes shall be provided at the low points in the end brackets and shall be supplied with corrosion resistant breather drain plugs.
 3. Ventilating fans shall be of non-sparking conductive plastic material. The proper fan rotation direction shall be indicated by a permanent label on the outside of the motor.
 4. The motor's conduit box shall be equipped with a ground lug. Gaskets shall be provided between the conduit box and frame, and between conduit box base and cover, to provide a moisture resistant barrier.
 5. Shouldered eyebolts with a minimum safety factor of 10 shall be provided for motor lifting. All fastening hardware shall be hex-head bolts or socket head cap screws with zinc plating. Cast iron motor components shall be primed and painted to surpass a 250-hour salt spray test per ASTM B117-90.
- G. **Nameplate.** Motor nameplate shall be stainless steel, and shall contain the following information in addition to that noted in section 10.40 of NEMA MG1-1993.
1. AFBMA bearing ID.
 - a. Manufacture date code.
 - b. Motor weight.
 - c. Guaranteed minimum efficiency.
- H. **Airborne Sound.** Motor sound power level, when measured at a no load condition, shall not exceed 90 dBA, when determined in accordance with IEEE Standard 85-1973.

- I. Vibration. Motor vibration measured in any direction on the bearing housing meets the levels listed below when tested per section 12.08 of NEMA MG1-1993:
 - 1. Unfiltered vibration at rated voltage and frequency shall not exceed 0.15 in/s peak velocity.
- J. Production Tests. The motor manufacturer shall perform production tests according to NEMA MG-1-12 and ANSI/IEEE Standard 112, Method B.
 - 1. The following test information shall be recorded and inserted in the motors' shipper.
 - a. Winding Resistance.
 - b. No load current and speed at rated line voltage and frequency.
 - c. Current input at rated frequency with rotor at stand-still.
 - d. High-potential test.
 - e. The following five unfiltered vibration readings, measured as described above: drive end (horizontal, vertical, and axial) and opposite drive end (horizontal and vertical).
- K. Warranty. Motor components shall have a full three-year performance warranty when operated on sine wave power and three-year warranty on inverter power.
- L. Manufacturers and Models.
 - 1. TECO Westinghouse MAX-E1 Premium Efficiency Severe Duty TEFC.
 - 2. Siemens – Medallion Motors, Premium Efficiency Severe Duty TEFC Type CZ.
 - 3. WEG Severe Duty TEFC.
 - 4. US Motors Catalog No. C50P2C.
 - 5. Baldor TEFC.
 - 6. Or Approved Equal

Listed manufactures/models establish minimum quality and performance expectations and are not intended to restrict equivalent products.

SECTION 10.0 Motor Starter Panel

- A. General. Starters matched to the compressor prime movers, cooler-fan motors, and pre-lube pump motors as applicable shall be provided with the compressor system, shall be controlled by the programmable-logic control (PLC) system and shall be located in a non-hazardous area, or in a hazardous area if panel is listed for Class 1 Division 2 Group D service per NEC. For starter assemblies located outside of the hazardous area, house in NEMA 3R or NEMA 4 cabinet. All motor starters shall include TVSS protection.
- B. Electromechanical Motor Control.
 - 1. Compressor fan drive motors and pre-lube pump motors shall be controlled by Full-Voltage Non-Reversing (FVNR) magnetic starters, i.e. across-the-line starters.
 - 2. Magnetic starters through NEMA Size 9 shall be equipped with double-break silver alloy contacts. The starter must have straight-through wiring. Each starter shall have one (1) NO auxiliary contact.
 - 3. Solid-State Overload Relay.
 - 3.01 Provide a solid-state overload relay for protection of the motors. The relay shall be Cutler Hammer type CEP7 or approved equal.
 - 3.02 The overload relay shall be modular in design, be an integral part of a family of relays to provide a choice of levels of protection, and be listed under UL Standard 508.
 - 3.03 The overload relay shall have the following features

- a. Be self-powered.
 - b. Class 10 or 20 fixed tripping characteristics.
 - c. Manual or automatic reset.
 - d. Provide phase loss protection. The relay shall trip in 2 seconds or less under phase loss condition when applied to a fully loaded motor.
 - e. Visible trip indication.
 - f. One NO and one NC isolated auxiliary contact.
 - g. Test button that operates the normally closed contact.
 - h. Test trip function that trips both the NO and NC contacts.
 - i. A current adjustment range of 3.2:1 or greater.
 - j. Ambient temperature compensated.
 - k. Ground fault protection. Relay shall trip at 50% of full load ampere setting.
 - l. Jam/Stall protection. Relay shall trip at 400% of full load ampere setting, after inrush.
 - m. FVNR Motor starters shall be Cutler-Hammer Freedom Series or approved equal.
- C. Solid-State Reduced Voltage Motor Control for compressor drive. For this procurement, vendor shall provide 1x MCC to drive one CNG compressor and appurtenances specified under this base procurement.
1. Controller for each compressor prime mover shall be Cutler-Hammer type S811 or equal, and shall have PLC control unit complete with built-in 24VDC control power transformer or other similar programmable soft starter.
 2. The solid-state reduced-voltage starter shall be UL and CSA listed.
 3. The solid-state reduced-voltage starter shall be an integrated unit with power SCRs, logic board, paralleling bypass contactor, and electronic overload relay enclosed in a single molded housing. The SCR-based power section shall consist of six (6) back-to-back SCRs and shall be rated for a minimum peak inverse voltage rating of 1500 volts PIV.
 4. Units using triacs or SCR/diode combinations shall not be acceptable.
 5. Resistor/capacitor snubber networks shall be used to prevent false firing of SCRs due to dV/dT effects.
 6. The logic board shall be mounted for ease of testing, service and replacement. It shall have quick disconnect plug-in connectors for current transformer inputs, line and load voltage inputs and SCR gate firing output circuits.
 7. The paralleling run bypass contactor shall energize when the motor reaches 90 of full speed and close/open under one (1) times motor current.
 8. The paralleling run bypass contactor shall utilize an intelligent coil controller to limit contact bounce and optimize coil voltage during varying system conditions.
 9. The coil shall have a 5-year warranty.
 10. Starter shall be provided with electronic overload protection as standard and shall be based on inverse time-current algorithm. Overload protection shall be capable of being disabled during ramp start for long acceleration loads via a DIP switch setting on the device keypad.
 11. Overload protection shall be adjusted via the device keypad and shall have a motor full load ampere adjustment from 30 to 100% of the maximum continuous ampere rating of the starter.
 12. Starter shall have selectable overload class settings of 5, 10, 20 or 30 via a DIP switch setting on the device keypad. Starter shall be capable of either an electronic or mechanical reset after a fault. Units using bimetal overload relays are not acceptable. Over-temperature protection (on heat sink) shall be standard. Starters shall provide protection against improper line-side phase rotation

SECTION 11.0 INSTRUMENTS AND CONTROLS FOR COMPRESSOR SYSTEM

- A. General. Compressor-system controls, including start and shutdown shall be electronic and shall operate automatically and unattended by a remote PLC, provided under a separate contract. Provide local I/O module in the compressor skid for connection to and control by a remote master PLC that is provided by others. Module shall be wired to and equipped with analog and digital sensors, transducers, transmitters and switches as required for items under paragraph 2.08.
- B. Control System. Each skid shall include a local junction for input-output functions, which shall be supervised by a remote PLC:
1. Compressor-Skid Interface. Provide compressor skid with an Allen Bradley Point I/O module or approved equal for digital or analog monitoring of skid functions as recommended by compressor-skid manufacturer. Furnish compressor skid with a 7" touch-type HMI display. Wire module to separate remote master PLC using CAT-6 Ethernet cable. Module shall connect to, control, and monitor the following items:
 - a. Motor start/run, including temperature permissives, and RPM.
 - b. Suction pressure.
 - c. Each-stage & final-stage discharge pressure.
 - d. Each-stage discharge temperature, including discrete per cylinder.
 - e. Blowdown pressure.
 - f. Oil flow.
 - g. Oil temperature.
 - h. Compressor vibration (analog).
 - i. Cooler-fan vibration (analog).
 - j. Methane detection.
 2. Configuration of Point I/O Module. The compressor skid shall be equipped with an integrated module that includes the following components:
 - a. 002 1734-IV8 24V – DC 8-Point Source Input Module
 - b. 007 1734-TOP – One-Piece Terminal Base, 8-point, Screw Clamp Terminals
 - c. 002 1734-OB8 – 24V DC 8-Point Source Output Module
 - d. 002 1734-IE8C – 8-Channel High-Density Analog Current Input Module
 - e. 001 1734-IE4C – 4-Channel High-Density Analog Current Input Module
 - f. 001 2711P-T7C21D8S – Graphic Terminal, Standard Model, 6.5 in. Display, TFT Color, Touch Screen, Single Ethernet, 18-30 V DC
- C. Shutdowns, Alarms and Annunciators.
1. General. Coordinate program to remote master PLC with compressor manufacturer as required to facilitate shutdowns, alarms and annunciators. These functions of the new compressor skids shall be monitored by the master PLC, and shall be electronic and adjustable. The actual PLC-programming will be performed by compressor manufacturer, based on coordination provided by the Contractor.
 2. Specifications. The first column, below, lists the relevant component or system. The second column lists the corresponding required action (i.e. shutdown, alarm, indicator):
 3. Compressors:
 - a. Low suction pressure: Shutdown

b. High interstage pressure, all stages:	Shutdown
c. High discharge pressure:	Shutdown
d. Low lube oil pressure:	Shutdown
e. High discharge temp., each cylinder:	Shutdown
f. High compressor & cooler vibration:	Shutdown
g. High vibration:	Shutdown
h. 20% LEL methane detection level:	Alarm
i. 50% LEL methane-detection level:	Shutdown
j. High storage pressure, each bank:	Shutdown
k. Nearing low control-air pressure (header):	Alarm
l. Low control-air pressure (air-supply header):	Shutdown
m. High blowdown pressure (95% MAWP):	Shutdown

D. Additional Requirements. In addition to the devices previously listed, the skid controller shall include:

1. Manual shutdown switch.
2. Lights to indicate main power is energized, condition light for each compressor indicating "running", "standby" or "fault."
3. Compressor automatic-start-cycle failure.
4. First-out fault annunciation.
5. An emergency shutdown switch shall be provided at the control panel. The ESD switch shall shut off the compressor drive motor gas supply and close the actuated suction valve at each compressor. ESD system shall be expandable to other locations on a common 24VDC or 120VAC circuit.
6. Hour meter. Each compressor shall have a non-resettable hour meter to record cumulative time of operation and may be part of a multi-functional digital display with a backup battery.
7. Motor overload. The annunciator need not specifically call out "compressor NG- motor overload". Rather the annunciator may indicate a message such as "compressor motor failure"
8. Temperature for high interstage and discharge temperatures shall be measured at the outlet of each cylinder.

E. Instrumentation.

1. Temperature Measurement. Thermocouples or resistance thermometer devices (RTDs) shall be used to sense temperature for control functions.
2. Pressure Measurement.
 - a. Required Pressure Gauges. Pressure gauges shall be provided for compressor suction, interstage pressures, blowdown receiver and final compressor discharge for each compressor.

- b. Calibration Valve. All pressure switches and transducers/transmitters shall have a dedicated block-and-vent valve to facilitate pressure calibration. The block valve should be lockable with a wire and lead seal.
- c. Pressure Gauges. Manual pressure gauges shall monitor the following pressures:
 - I. Compressor lube oil
 - II. First-stage suction
 - III. Each stage discharge
 - IV. Blowdown receiver

F. Connectivity.

Wire I/O module to remote-master PLC using cat 5E Ethernet cable. Route cable in RGC conduit and provide seal fittings at each end of conduit. Support and anchor conduit to concrete slab with galvanized steel Unistrut and conduit clamps at maximum spacing of 5ft O.C.

- 1. Allen Bradley 'Point I/O' module.
- 2. Approved Equal.

SECTION 12.0 Emergency Shutdown System

- A. General. An emergency shutdown system shall be provided that, when activated, shall interrupt the power supply to the compressor skids, shut down compressors, shut off the inlet natural gas supply valve to the compressors and shutoff the electrical power and the discharge of CNG to the dispensers. The system shall be controlled in the control panel, common to all compressors, be on a normally closed circuit and shall be expandable with 40% additional capacity so that additional switches may be added in future. Buttons shall be push-in mushroom-head type and appropriately rated as required by location.
- B. Specification.
 - 1. Circuit. ESD shall be 120VAC normally closed serial-type circuit, so that the opening (activation) of any ESD switch shall cause an ESD fault. Control panel shall require manual reset from ESD activation.
 - 2. Buttons. ESD buttons shall be red mushroom-headed press-to-open type and must be pulled out to reset. All buttons shall have a protective fence flush with its face in order to minimize accidental pressing. Buttons shall be rated for class-1 division-2 service if located within a hazardous area.
 - 3. Locations. Install one ESD button on each new compressor skid. face in order to minimize accidental pressing. Buttons shall be rated for class-1 division-2 service if located within a hazardous area.
 - 4. Locations. Install one ESD button on each new compressor skid.

SECTION 13.0 Execution

- A. Execution is described in the respective Product description of this section.
- B. All components and equipment shall be installed according to the respective manufacturers' instructions and recommendations. Industry-standard practices shall apply if no manufacturer instructions exist.
- C. PIPING AND APPURTENANCES
 - 1. General. Seamless stainless-steel tubing, stainless steel pipe, or seamless carbon steel pipe shall be used to conduct CNG. Cap any unused (i. e. future) tubing and/or piping.
 - 2. Service Pressure. Piping, tubing and appurtenances downstream of compressor discharge shall have a manufacturer-rated working pressure of 5,000 PSI, in accordance with ANSI B31.3, *Process Piping*.
 - 3. Shipping. While in transit, all hose and flexible metal hose and tubing, including their connections, shall be protected from wear or injury and shall be capped.
 - 4. Markings. Hose, metallic hose, flexible metal hose and tubing shall be distinctly marked either by the manufacturer's permanently attached tag or by distinct markings every 5 feet indicating the manufacturer's name or trademark, material grade, service and working pressure.
 - 5. Dissimilar Metals. Connections between dissimilar metals shall include dielectric insulation. This includes piping and other metallic connections.
 - 6. Blowdown Tees. Within specified equipment, piping and high-pressure tubing systems and sections shall be equipped with blocking ball valves and blowdown tees or needle valves to facilitate equipment maintenance. Blowdown valves shall discharge in a manner that directs the discharging gas safely away from the person using the blowdown valve. Discharge lines on blowdown valves shall be equipped with threaded end caps to seal the line in normal service, so as to prevent accidental line depressurization and gas release. Block valves and blowdown tees shall be provided at all filter locations for safe depressurization of filter housings.
 - 7. Pipe Routing. All gas, CNG and control-air piping inside the CNG-equipment compound shall be located and routed aboveground, unless shown as dashed piping on the as-built drawings. Piping may be installed below grade, if it is installed in a pre- cast concrete pipe trench that is covered and rated for traffic and loads to which it may be exposed. Piping shall be ganged on common runs, racks and carriers where appropriate and shall be insulated against cathodic action and contact with dissimilar metals. Piping and tubing outside of the compound shall be routed underground.
 - 8. Pipe Specification. Pipe containing flammable material shall be seamless carbon steel manufactured in accordance with ASTM A-106 Grade B. All pipe, fittings and other piping components shall be suitable for the full range of pressures, temperatures and loadings to which they may be subjected with a factor of safety of at least four (4). Any material used, including gaskets and packing, shall be compatible with natural gas and its service conditions.
- D. Connections.
 - 1. Small Pipe Connections. For 2-inch or under nominal pipe size with maximum operation pressure greater than 15 PSIG, the connections shall be socket welded in accordance with

ASME/ANSI B31.3, except that twenty-five (25) percent random dye-penetrant examination and one hundred (100) percent visual examination is required. Each weld shall be de-scaled and internally cleaned from any welding slag. Documentation of examination shall be transmitted to the Owner within 5 working days of examination. One hundred (100) percent of pipe welds made outside of the CNG-equipment area shall be inspected via dye-penetrant examination.

2. Large Pipe Connections. For over 2-inch nominal pipe size with maximum operation pressure greater than 15 PSIG, the connections shall be, butt welded in accordance with ASME/ANSI B31.3 except that twenty-five (25) percent random radiographic x-ray examination and one hundred (100) percent visual examination is required. Each weld shall be de-scaled and internally cleaned from any welding slag. Documentation of examination shall be transmitted to the Owner within 5 working days of examination.
3. Flange Joint. Flanges shall be in accordance with ANSI B16.5. Weldneck raised face flanges shall be used unless specified otherwise. Ring-type joints or spiral-wound metallic gaskets with centering ring shall be employed for ANSI class 900 flanges or higher.
4. Sealing. Threaded pipe joints shall be seal welded. However, seal welding is not required on instruments or where disassembly is required for maintenance.
5. Pre-start Pipe Cleaning. Piping sections between packaged components that include piping or tubing intended for CNG shall be blown clean prior to connection to equipment. Blow out shall be achieved by closing the downstream end of pipeline with a 5,000 PSI-rated ball valve, connecting a minimum 1,650 PSI-source pressure vessel to the upstream end of the pipeline, opening supply valve at source so that minimum 750 PSI accumulates in pipeline, then opening outlet ball valve to atmosphere. Procedure shall be repeated until no solid or particulate matter is discharged from the pipeline. For gas-supply lines, limit pressure to 300 PSIG and for compressed air lines, limit pressure to 200 PSIG.
 - 1) Personnel opening and closing ball valve at downstream end shall take care to keep clear of the discharge path of the blowout, and shall wear eye and ear protection during procedure.
 - 2) Direction of blowout flow shall be performed in both directions if possible.
 - 3) Contractor shall take care to clear area at pipeline discharge to prevent property damage or injury during procedure.
6. Startup Filtration. 'Witch's hat' or similar strainer devices shall be installed where practical at termination of such piping sections prior to system startup and shall be checked, cleaned and replaced by the Contractor as required until all residual pipe debris has been removed.
 2. Pipe Fabrication. All internal pipe surfaces of piping between components shall be cleaned over its entire length, removing dirt, debris and loose corrosion products before pipe is lined up for welding. The open ends of all strings of pipe shall be kept securely closed to prevent the entrance of dirt, debris, water or animals into the pipe.
 3. Field-applied Paint. All aboveground carbon steel pipe, pipe supports, and pipe bollards shall be painted using a suitable industrial maintenance coating, including exterior grade, and resistance to UV. Surface preparation and selection and application of primer and finish coat shall conform to the paint manufacturer's written instructions.

E. High-Pressure Tubing.

1. Tubing Specification. Gas tubing shall be stainless steel ASTM A-213 or ASME SA213 cold drawn, bright annealed seamless tubing. Tube material shall be Type 316 stainless steel.
2. Installation of Tubing and Tube Fittings. Swagelok, Parker A-Lok, or Hoke tube fittings shall be used. Contractor shall use tube fittings from a single manufacturer throughout a prepackaged component, to simplify use and consistency of appropriate repair parts. Type 316 stainless steel fittings shall be used with stainless steel tubing. Manufacturers' personnel who install tubing and tube fittings shall be trained and certified by the fitting manufacturer for such activity, and proof shall be provided. Tubing shall be installed neatly and in a workman-like manner as per manufacturer's design and recommendation. All tubing shall be properly anchored, supported or pitched and shall be protected from impact. As CNG tubing dilates and contracts in response to its wide range of operating pressures, Parker ParKlamp assemblies, or approved similar resilient anchors, shall be used to support gas tubing. Parker Seal-lok fittings shall be used for tube fittings for tubing $\frac{3}{4}$ " or larger.
3. Valve Clearance. All valves shall be accessible for easy operation and maintenance.

F. Instrument Piping. Provisions shall be made for the installation of piping and tubing to accommodate field servicing and calibration of instruments.

G. Valves.

1. General. All valve bodies shall be permanently marked by the manufacturer with their service pressure ratings.
2. Shut-off Valve. A full-port manual ball valve shall be installed immediately downstream from the connection to each compressor-discharge line and the skid outlet line, to facilitate servicing.
3. Compressor Discharge Check Valve. A backflow preventer (check valve) shall be provided at each high-pressure outlet, to prevent backflow into the compressors from ancillary equipment. Backflow preventers shall be suitable for use at the maximum pressure to which they are subjected.
4. Pressure Relief Valves. Pressure relief valves installed to protect each isolated piping system shall have sufficient capacity and shall be set to open at a pressure not exceeding 125% of system MAWP or the pressure which produces a hoop stress of 75% of specified minimum yield strength, whichever is lower. Pressure relief valve (PRV) shall be of the following type, or approved equal: Anderson Greenwood Type fabricated with stainless steel, having an orifice size appropriate for the pressure and volume/rate that it is protecting.
5. Stamping. All relief valves shall be ASME rated and stamped with their set pressure and date of setting by manufacturer. Date stamp shall be less than 12 months from date of delivery to site.
6. Control. There shall be no shutoff means in the discharge line of a pressure-limiting device or between the relief valve and the pressure source that it controls.

7. Relief Valve Venting. Each relief valve shall be connected to a vent pipe constructed of schedule 80 carbon steel pipe with primed and epoxy coating or approved equal coating. The vent pipe shall vent released gas at an elevation 10 feet above grade or another approved, safe location and shall be properly anchored and supported against anticipated vent force. Escaping gas shall not impinge on a vessel, valves or fittings. Except for safety valves that are integral with service valves, relief-valve vent pipes on tanks shall be installed in a vertical position and shall be fitted weep holes at the low point of the pipe.
8. Relief Valve Vents. Each vent pipes shall be capped with rain caps as a means of preventing the entry of water and debris.
9. Prohibited Pressure Relief Devices. Fusible plugs and/or rupture plugs are prohibited for primary relief devices.
10. Actuated Valves. All valves requiring automatic actuation shall be ball type with port sizes not smaller than the largest line connection. Actuators shall be pneumatic, and matched to valve, subject to Owner approval. Solenoid valves or actuation by regulated gas or electric operators are prohibited unless specifically approved by the Owner.

H. LABELING

1. Major Equipment. The manufacturer shall provide a stainless steel or brass nameplate on each major item of equipment. The nameplate shall be mechanically affixed and shall be embossed with the manufacturer's name, address, model number, serial number, pressure rating and flow capacity.
2. Valves. The Contractor shall provide a uniform brass or stainless-steel embossed nameplate on or adjacent to valves located as listed below. The nameplate shall be mechanically affixed.
3. Gas and CNG connections at the exterior perimeter of the compressor skids.
4. All valves for the control-air system.

I. FIELD-STARTUP SERVICES

1. General. Contractor shall provide field-startup services performed by manufacturers' authorized representatives for each phase separately, including on-site assistance as required for the following equipment, and including integration as required:
 - a) Compressor skid.
 - b) Motor-starter system
 - c) Revisions to remote master PLC control system.
 - d) Emergency-shutdown system.
2. Joint Meetings. Contractor shall facilitate joint, on-site meeting(s) consisting of technicians from the Contractor, Contractor's electrical subcontractor, Contractor's mechanical-piping subcontractor, all other related subcontractors and CNG-skid manufacturer. First joint meeting shall be conducted upon completion of all mechanical connections, final terminations and energizing of all systems listed herein, for the purpose of coordinating debugging activities. Contractor shall facilitate as many such joint meetings as may be required to achieve acceptance and test compliance.

SECTION 14.0 Adjusting, Balancing And Testing

- A. After completion of the installation, start, regulate, adjust and test all equipment and devices. This section is applicable to each phase of construction. All adjusting, balancing and testing, as specified herein, shall be performed upon completion of each phase.
- B. Functional Tests.
1. Leak tests of high-pressure CNG piping sections, systems and appurtenances shall be performed by maintaining a nitrogen charge of 110 percent of its respective working pressure for a duration of 30 minutes with charge source disconnected. The tests shall use a gauge that is scaled to between 110 percent and 300 percent of the test pressure. Piping and tubing shall also be subject to soap-bubble testing. See Mechanical General notes for test procedure.
 2. Functional Testing. At minimum, successful completion of the following functional tests shall be required.
 - a. ESD / emergency shutdown at all button/station locations, including required valve closures.
 - b. Low suction pressure, each skid (close skid-supply ball valves).
 - c. Correct annunciation on controller / PLC shall be required for all test events, as appropriate.
 - d. Observe compressor operation, including stage pressures and temperatures, and verifying function of controller, including triggering selected faults, such as high interstage temperature.
 3. Reliability Test. Reliability test shall consist of fueling under normal-use conditions for 5 consecutive workdays. System shall have no failures of operation of contractor-provided equipment and materials, nor for PLC with respect to modifications made to accommodate and connect to the new equipment. If any failure occurs, the test shall be repeated in its entirety. Contractor shall be responsible for all onsite coordination of troubleshooting and coordination of suppliers and trades during test.
 4. Failure is defined as the occurrence of any of the following:
 - a. Inability of the CNG system to dispense CNG at the pressures and rate specified, including accounting for temperature compensation at settled conditions.
 - b. Failure of a compressor to start and run within factory-listed operating pressures and temperatures.
 - c. Failure of the controller/PLC, to control compressors and rest of the CNG fueling system.
 - d. Presence of an audible or visible gas or CNG leak.
 - e. Occurrence of an auto-fault shutdown of either or both CNG compressors, except those caused by ESD-button activation, gas-detection system outside of skids, variations in gas supply pressure, or damage to the facility beyond the Contractor's control.
 - f. Failure of site ESD valve to close upon ESD event or no compressor running, and to open when minimum of one compressor is running.
 5. Contractor may take equipment offline for scheduled maintenance during the test period, provided maintenance is consistent with manufacturer's recommendations, and does not

restrict Owner's ability to fuel vehicles during the normal daily fueling window between 4:00PM and 11:00PM. Contractor shall be responsible for maintenance through successful completion of test, including provision of consumables.

6. Corrective work conducted by the Contractor and all subcontractors and suppliers preceding and during the performance test shall be documented at the time of the repair by the technician performing the repair. If the technician suspects a cause of fault that is beyond the scope of his respective firm or responsibility, technician shall notify Owner immediately and shall not repairs until condition of failure has been documented and the other firm(s) have been notified and been provided documentation of the condition.

C. CNG Fueling Operation and Maintenance Training.

1. General:

- a. At least 60 days prior to scheduled date for commencement of training, submit training syllabus with time allotments per topic and instructional materials to the Owner for review and approval. Upon review of syllabus, Owner may require additional time be allotted to certain training topics.
- b. Where specified, develop and conduct a program to train selected Owner personnel in the safe operating procedures, and maintenance of equipment and systems furnished during the hours required by the Owner. Also include in the training program key hazards and their protectors, and corrective actions for violation of safety rules.
- c. Furnish instructors, instructional materials and audio-visual aids and equipment.
- d. Owner will provide physical facilities and equipment for training.
- e. Begin instruction upon successful completion of Testing as specified in this Section.

2. Program content: At a minimum, instruction shall include material covered in the operation and maintenance manuals as well as the following:

- a. Theory of operation of CNG system.
- b. Practical aspects of operation.
- c. Description of system, equipment and components.
- d. Functional characteristics of system, equipment and components.
- e. Emergency operating procedures.
- f. Maintenance procedures.
- g. Servicing intervals and schedules.
- h. Diagnosis and problem solving (troubleshooting).
- i. Repair.
- j. All segments characterizing CNG equipment.
- k. Instruction manual will contain measurable training objectives.
- l. Hazards relative to CNG Facility operations.
- m. Conduct preventive maintenance checks and services.

- n. Perform general and location Emergency Response.
- o. Perform personal precautions in Emergency Situations such as Fires, Leaks or Spills.
- p. Perform corrective actions to respond to Emergency Situations such as Fires, Leaks or Spills.
- q. Operations and Safety personnel will perform CNG Shop Operations such as Prepare Maintenance Request; Maintain Records for Hazard of CNG Operations.
- r. Perform CNG vehicle fueling.
- s. Operation, reading, interpretation and resetting of master control panel.

D. Special tools or equipment.

1. Contractor shall supply special tools or equipment.
 - a. The special equipment or tools are defined as, other than those nominally found in a mechanic's toolbox, necessary for the general upkeep, maintenance and overhaul of the equipment or products contained in equipment and components delivered under this contract.
 - b. A list of special tools or equipment shall be provided to the Owner for approval no later than 60 days after award.
 - c. Any tools not found in the catalogue or over-the-counter of a local supply company is considered a specialty tool or equipment.

E. Duration.

1. Training for maintenance, operation and troubleshooting shall be 4 total hours.
2. Actual durations for each type of training may be reduced at the discretion of the Owner.

F. AS BUILT DRAWINGS

A. Contractor shall provide the following items when project is completed:

1. Printed Copies: Supply one (1) complete printed copy of redlined as-built drawings.
2. Electronic Copies: Supply one (1) complete copy of redlined as-built drawings in electronic PDF format, with matching content and organization matching the printed copy. PDF shall be text searchable, and media shall be USB flash drive with label or tag.

END OF CNG EQUIPMENT & SYSTEMS

SECTION 15: EVALUATION & RVTD’S RIGHTS

The Proposal and the required documents described in this RFP will be evaluated by a committee of RVTD personnel and subject matter experts. 220 total points can be awarded. Complete proposals will be evaluated based on the following criteria:

1	<p>Project Understanding & Technical Capacity</p> <p>10 points each</p>	<p>60 points available</p>
<ul style="list-style-type: none"> • Completeness of proposal addressing Sections 2-3. • Completeness of proposal addressing Sections 5-14. • Ability to integrate proposed equipment with the District’s existing electrical, gas utility, controls, and facility infrastructure. • Proposed project schedule and transition plan • Ability and proposed methodology to provide temporary fueling capability during construction, testing and commissioning activities. • Quality, completeness and feasibility of the proposed implementation and commissioning plan. 		
2	<p>Qualifications & Experience (See Section 4. A-C)</p> <p>10 points each</p>	<p>40 points available</p>
<ul style="list-style-type: none"> • Demonstrated experience performing projects of similar size, complexity, and operational criticality. • Experience designing, retrofitting or replacing CNG fueling infrastructure at active transit or municipal fleet facilities while maintaining fleet operation continuity. • Financial stability and organizational capacity of the Contractor, equipment manufacturers (if different) and key subcontractors. 		

3	Contractor References (see Section 4. D) 10 points each	30 points available
<ul style="list-style-type: none"> • Satisfaction of references regarding project management, communication, schedule adherence, and workmanship quality. • Demonstrated track record of successful installation, testing, and long-term support of comparable CNG fueling systems. • Documented reliability and commissioning of installed systems. 		
4	Cost (see 15.8) 10 points each	50 points available
<ul style="list-style-type: none"> • Clarity and completeness of cost proposal. • Reasonableness of price for ‘soft costs’. • Reasonableness of price for equipment, installation, testing and commissioning. • Total cost of proposed two-year extended warranty and five-year service agreement, including optional renewal periods. • Availability and cost of critical replacement parts. 		
5	Equipment Lifecycle Cost and Reliability 10 points Each	50 points available
<ul style="list-style-type: none"> • Proposed redundancy and fail-safe features to minimize fueling interruptions. • Proposed guaranteed onsite response time for critical fueling system failures • Projected maintenance intervals and overhaul requirements. • Expected major equipment component lifespans. • Warranty support guarantee and manufacturer commitment to long-term product support. 		

15.1 Pre-Proposal Conference

A Pre-proposal Conference will be held on **June 15, 2026**, from 10:00AM to 11:00AM PST. CONTRACTORS can submit questions in advance via email until **June 13, 2026**, at 5:00 PM PST to RFP@rvtd.org and shall reference RFP #CNGCOMP26 in the subject line. Questions may be read and answered during the virtual meeting. Additional questions may be asked during the virtual meeting. RVTD will send the agenda and virtual meeting link to the Responders list prior to the meeting date. Proposers are encouraged to attend in person however it is not required. The Pre-proposal conference will include a tour of the existing CNG Facilities.

15.2 Responders List

Only those persons who contact RVTD by email or in writing will be on the Responders List. The Responder's List is used to send updates and amendments regarding this RFP. RVTD will not automatically send notifications regarding this RFP to other outlets though updates will be available on our website at www.rvtd.org/about/RFP. To participate in the Responders List please email the request to RFP@rvtd.org or send to Debbie Wilbur, 101 S. Front Street, Medford, Oregon 97501. RVTD shall maintain the right to distribute the responders list upon request.

15.3 Technical Questions

CONTRACTORS have the opportunity to submit questions. Questions will need to be submitted no later than June 18, 2026 by 5:00PM (PST). RVTD intends to publish responses to all questions, including those submitted for the Pre-proposal conference, by **June 23, 2026 at 5:00PM (PST)**. RVTD reserves the right to condense similar questions into one inquiry. RVTD will respond to the questions via pdf and emailed to the Responders list and posted online at www.rvtd.org/about/RFP. Questions, Responses and, if necessary, Addendums will be available online at www.rvtd.org/about/RFP. ALL TECHNICAL QUESTIONS SHOULD BE SENT TO: RFP@rvtd.org and shall reference RFP #CNGCOMP26 in the subject line.

15.4 Proposals and All Required Material

Hard copies of the Proposals and All Required Material are due to RVTD no later than **June 30, 2026, at 5:00PM (PST)** to 101 S. Front Street, Medford, Oregon 97501 with "CNG Compressor Skid Project # CNGCOMP26" written on the package. Proposals can be dropped off in person at 101 S. Front Street, Medford, Oregon 97501 with notice. RVTD reserves the right to allow CONTRACTORS to submit incomplete or missing information from Section 6 only by the end of the day July 1, 2026, by 5:00PM (PST).

15.5 Evaluation of Proposals

Proposers' responsiveness to all required materials will be evaluated using the criteria in Section 15 and 16. An Evaluation Committee will review the proposals and independently score each proposal. The Evaluation Committee will convene to discuss the scores and calculate averages across each scorer. RVTD has the right to designate a 'competitive range' determined by the average scores if it identifies a significant gap between higher and lower score totals. RVTD will notify proposers who are deemed not to be within the competitive range and will not continue to be considered by RVTD.

RVTD may request all proposers who are within the competitive range to participate in an interview. RVTD will contact proposers to select an interview date and time for the week of **July 27th**. RVTD's Evaluation Committee may revise the original scores using the responses from the interviews to identify which proposers should remain within the competitive range. Best and Final offers may be requested from only those proposers who have been identified as remaining within the competitive range by the Evaluation Committee.

15.6 BAFO and Award

Written requests for Best and Final Offer will be published to CONTRACTORS who remain within the competitive range. Best and Final Offers will be due to RVTD no later than **August 13, 2026, by 5:00PM (PST)**. Anticipated Intent to Award is scheduled on or before August 19, 2026. CONTRACTOR shall not begin work until Notice to Proceed Letter has been received, which is scheduled to occur on or before September 14, 2026. Substantial Project Completion shall occur by August 1, 2027.

15.7 Required Proposal Forms

Required Proposal Forms, located in Section 16 must be submitted with the Proposal for a proposer to be considered responsive. All required forms are contained within the proposal documents and located in Section 16: Required Proposal Forms. Non-responsive proposals may be rejected.

15.8 Pricing and Cost Forms

Proposers shall clearly identify costs using their preferred method such as a separate spreadsheet itemizing the costs. If pricing is included throughout the proposal document, a summary table is required. Proposals shall separate the initial Design phase costs which may include but are not limited to on-site analysis, consultation with RVTD staff, design drawings and report. Travel related costs must be listed separately.

Costs related to on-site work, virtual meetings, project management tasks, travel and other 'soft costs' shall be listed separately from the direct costs associated with the equipment and installation.

All construction associated costs must conform with the Davis Bacon Act and Prevailing Wage.

15.9 Proof of Insurability

CONTRACTORS must submit a copy of their current certificate of insurance (COI) with their proposal. If the COI does not include the required coverage and minimum limits, CONTRACTORS must submit a letter from their insurance provider stating the provider's commitment to insure the CONTRACTOR, if awarded the contract, for the types of coverage and at the limits specified within this RFP.

15.10 Term of Contract

RVTD will enter into a 5-year contract with two 5-year renewal options. The initial 5-year term will begin approximately on September 14, 2026 or upon contract execution and expire September 13, 2031.

15.11 Independent Contractor

- A. The parties intend that an independent relationship will be created by this contract. RVTD is interested primarily in the results to be achieved; the implementation of services will lie solely with CONTRACTOR. No agent, employee, servant or representative of CONTRACTOR shall be deemed to be an employee, agent, servant or representative of RVTD for any purpose, and the employees of CONTRACTOR are not entitled to any of the benefits RVTD provides to its employees. CONTRACTOR will be solely and entirely responsible for its acts and for the acts of its agents, servants, SUBCONTRACTORS or representatives during the performance of this Contract.
- B. In the performance of the services herein contemplated, CONTRACTOR is an independent CONTRACTOR with the authority to control and direct the performance of the details of the work. However, the results of the work contemplated herein must meet the approval of RVTD and shall be subject to RVTD's general rights of inspection and review to secure the satisfactory completion thereof.
- C. CONTRACTOR shall designate a representative to act on its behalf. Said representative shall have full authority to direct all affairs in respect to the work performed under this Contract.

15.12 Assignment and/or Subcontracting

RVTD and CONTRACTOR, each for himself, binds himself, his principals, successors, assignees and legal representatives of such party in respect of all covenants of this Contract. This Contract and all obligations arising thereunder shall not be sold, assigned or transferred by either party without the previous consent, in writing, of the other party to this Contract.

The performance of all activities contemplated by this Contract shall be accomplished personally by CONTRACTOR, persons and SUB-CONTRACTORS identified in the submittal. CONTRACTOR shall not assign or subcontract performance to others unless specifically authorized in writing by RVTD in advance. All terms and conditions of this Contract shall apply to any approved subcontract or assignment related to this Contract.

15.13 Safeguarding Client Information /Trade Secrets or Confidential Proprietary Data

CONTRACTOR agrees that confidential information obtained from RVTB shall not be disclosed except upon the written consent of RVTB.

RVTB may withhold from disclosure those portions of the proposal or bid that CONTRACTOR designates as trade secrets or as confidential proprietary data in accordance with applicable law. See ORS 192.501(2); 646.461 to 646.475. CONTRACTOR shall separate information designated as confidential from other nonconfidential information at the time of submitting its proposal.

15.14 Hold Harmless and Indemnification

- A. CONTRACTOR expressly agrees to indemnify and hold harmless RVTB and all of its officers, employees, agents or otherwise, from any loss, damages, costs, charges or expenses whether to persons or property, including any costs, expenses or attorney's fees in the defense of any claims therefore, which RVTB may incur by reason of any act, action, neglect, omission or default on the part of CONTRACTOR; provided however, as to any liability for damages arising out of bodily injury to persons or damage to property caused by or resulting from the concurrent negligence of RVTB and/or its agents or employees and CONTRACTOR or its agents and employees. This section is valid and enforceable only to the extent of CONTRACTOR'S negligence.
- B. In case any suit be brought against RVTB on account of any negligent act, action, neglect, omission or default of CONTRACTOR, CONTRACTOR hereby covenants to assume the defense thereof and pay any and all costs, charges, attorney's fees and other expenses and CONTRACTOR shall pay any and all judgments that may be incurred by or obtained against RVTB, except any judgments for liability for damages arising out of bodily injury to persons or damage to property caused by or resulting from the sole negligence of RVTB and/or its agents and employees, and except in the case of a judgment for liability for damages arising out of bodily injury to persons or damages to property caused by or resulting from the concurrent negligence of RVTB and/or its agents or employees, and CONTRACTOR and its/his agents or employees, the obligation of CONTRACTOR shall be limited and enforceable only to the extent of CONTRACTOR'S negligence.
- C. It is further provided that no liability shall attach RVTB by reason of entering into this contract, except as expressly provided herein.

15.15 Contract Changes

Either party may request changes to the scope of services and performance to be provided hereunder; however, no change or addition to this Contract shall be valid or binding upon either party unless such change or addition be in writing and signed by both parties. Such amendments shall be attached to and made part of this Contract.

15.16 Licensing in Compliance with Laws and Regulations

CONTRACTOR agrees to comply with all applicable federal, state, county, or municipal standards for the licensing, certifications, operation of facilities and programs, and accreditation and licensing of individuals, if any.

15.17 Insurance Requirements

Proposers must submit a copy of their current certificate of insurance (COI) with their proposal. If the COI does not include the required coverage and minimum limits, Proposers must submit a letter from their insurance provider stating the provider's commitment to insure the Proposer, if awarded the contract, for the types of coverage and at the limits specified within this RFP.

During the term of this Contract, CONTRACTOR shall purchase and maintain any insurance required by this Contract. CONTRACTOR shall be responsible for the payment of all premiums and deductibles and shall indemnify RVTD for any liability or damages that RVTD may incur due to CONTRACTOR'S failure to purchase or maintain any required insurance.

CONTRACTOR shall maintain insurance of the types and in the amounts described below.

1) Commercial General Liability Insurance

Commercial General Liability insurance, with coverage limits not less than:

- (a) \$2,000,000.00 per occurrence, bodily injury and property damage; and
- (b) \$2,000,000.00 general aggregate, bodily injury and property damage.

Such coverage will be equivalent to or better than the insurance Service Office (ISO) standard coverages, conditions, and extensions, and shall not contain limitations or exclusions for Blanket Contractual, Broad Form Property Damage, Personal Injury, Premises-Operations, Products and Completed Operations, Independent Contractors, Fire Legal Liability, and Explosion, Collapse, and Underground (XCU).

The General Liability policy shall be endorsed with CG 2010 1185 or CG 2010 1001 and CG 2037 1001 or equivalent, naming RVTD and its directors, officers, representatives, agents, and employees as additional insured.

2) Business Auto Liability Insurance

Automobile bodily injury and property damage liability insurance covering all motor vehicles, whether owned, non-owned, leased, or hired, with not less than the following limits:

- (a) Bodily Injury: \$2,000,000.00 per person; \$2,000,000.00 per accident; and
- (b) Property damage: \$2,000,000.00 per accident.

The Automobile policy shall be endorsed with CA 20 48 02 99 or equivalent, naming RVTD and its directors, officers, representatives, agents, and employees as additional insured.

3) Worker's Compensation Insurance

Oregon statutory workers' compensation and employer's liability coverage, including all states protection, if applicable, voluntary compensation and Federal endorsement. Employer's liability coverage shall have the following minimum limits:

- (a) Bodily Injury by Accident \$1,000,000.00 each accident
- (b) Bodily Injury by Disease \$1,000,000.00 each accident
- (c) Bodily Injury by Disease \$1,000,000.00 policy limit

CONTRACTORS who are non-subject workers meeting one of the exceptions in ORS 656.027 may not be required to carry workers compensation insurance. Any CONTRACTOR requesting an exemption from the workers compensation coverage listed above must make that request in writing, stating the

CONTRACTOR'S qualification for exemption under ORS 656.027 and shall maintain "if any" workers compensation insurance coverage.

Failure of RVTD to demand certificates of insurance, additional insured endorsements or other evidence of full compliance with these insurance requirements or failure of RVTD to identify a deficiency from evidence that is provided shall not be construed as a waiver of CONTRACTOR'S obligation to maintain such insurance.

The insurance required under this Paragraph will:

- 1) Include (as evidenced by endorsement) RVTD and its directors, officers, representative, agents, and employees as additional insureds with respect to work or operations connected with the contract (excluding Professional Liability and Worker's Compensation policies);
- 2) Require CONTRACTOR to give RVTD not less than thirty (30) days written notice prior to termination, cancellation, or non-renewal of coverage;
- 3) Insurance policies shall be purchased only from insurance companies with a rating criteria of "A-" or better (excluding SAIF) and are authorized to do insurance business in Oregon;
- 4) CONTRACTOR will cause its underwriters of insurance policies to waive their rights of subrogation arising from the work performed under this Contract. CONTRACTOR'S insurance shall apply as primary and will not seek contribution from any insurance or self-insurance maintained by, or provided to, the additional insureds listed above. This must be noted on the insurance certificate.

15.18 Liquidated Damages

CONTRACTOR understands that if the Substantial Completion is not achieved by August 1, 2027, as such date or duration may be amended by subsequent Change Order, Owner will suffer damages which are difficult to determine and accurately specify. CONTRACTOR agrees that if the date or duration set forth above in this paragraph is not attained, CONTRACTOR shall continue to have temporary onsite fueling available at no additional cost to the RVTD until substantial completion has been reached. Substantial completion is defined as the full implementation of the replacement CNG fueling equipment, completed commissioning and demonstrated functionality of all equipment, and the completion of the acceptance period. The liquidated damages provided therein shall be in lieu of all liability for extra costs, losses, expenses, claims, penalties, and other damages incurred by CONTRACTOR which are occasioned by delay in CONTRACTOR'S performance or in achieving Substantial Completion within the prescribed timeframe. In no event shall the total liquidated damages exceed \$75,000.

15.19 Notices

Any notice or demand under, or required by, this Contract shall be given in writing and shall be deemed properly given if received in due and timely course by the party for whom the notice was intended, or if sent by registered or certified mail, postage prepaid, to the intended party in care of the appropriate address below:

Rogue Valley Transportation District
Att: Debbie Wilbur
CNG Compressor Skid Replacement Project # CNGCOMP26
101 S. Front Street
Medford, Oregon 97501

15.20 Proposal Acceptance or Rejection

RVTD reserves the right to reject any or all proposals, to accept or reject any or all items in the proposal, to waive any informality in the proposals received, and to award the contract in whole or in part, if it is deemed to be in the best interest of the RVTD. RVTD reserves the right to negotiate with any consultant after proposals are opened, if such action is deemed to be in the best interest of RVTD.

In addition to the factors mentioned above, CONTRACTORS are cautioned to review carefully all terms, conditions and specifications of the RFP prior to submission of proposals. The work may be awarded on the basis of the CONTRACTOR'S proposal including the CONTRACTOR'S qualifications as received and without further discussion.

15.21 Proposal/Bid Protest

Any Proposer who has submitted a proposal to RVTD and who is adversely affected by the RVTD's contract award to another Proposer can submit a written protest of award to the RVTD. Such right to protest shall conform to the requirements of OAR 137-030-0104(1) and specify the grounds upon which the protest is based. RVTD's Bid Protest Procedures can be found at www.rvtd.org/about/rfpunder Bid Protest Procedures by copying the link on your browser.

15.22 Withdrawals and Modifications

Any proposals can be withdrawn or modified in writing by emailing RFP@rvtd.org, prior to the closing date.

SECTION 16: REQUIRED FORMS

16.1 Statement of Qualifications Certification

TO BE COMPLETED BY CONTRACTOR

- _____ Sole Proprietorship
- _____ Partnership (Limited / General)
- _____ Corporation

Contractor Name: _____

Address: _____

Federal Tax ID: _____

Phone Number: _____

Email Address: _____

STATEMENT OF QUALIFICATIONS CERTIFICATION

The undersigned is fully authorized to execute this certification on behalf of the CONTRACTOR and certifies on the CONTRACTOR'S behalf that, to the best of its knowledge, the information presented in this Statement of Qualifications is a statement of facts and that the CONTRACTOR has the financial capability to perform the work which is the subject of this solicitation. The CONTRACTOR further certifies that it knows of no personal and/or organizational conflicts of interest prohibited under federal, state and local law.

Signature _____ Date _____

Title _____

Disadvantaged Business Enterprise Certification

_____ The Bidder/Offeror hereby agrees to subcontract RVTD's minimum DBE goal requirement of 0.75% of the contract to disadvantaged business enterprises.

_____ The Bidder/Offeror (if unable to meet the DBE goal of .75%) is committed to a minimum of _____% DBE utilization on this contract and submits documentation demonstrating good faith efforts.

_____ The Bidder/Offeror will not participate in DBE participation.

NOTE: please check one of the above options.

CONTRACTOR Name: _____

Signature: _____

Title: _____

Date: _____

DBE PARTICIPATION SCHEDULE

The Bidder/Offeror shall complete the following information for all DBE's participating in the contract that comprises the DBE Utilization percent stated in the DEB Utilization Form. The Bidder/Offeror shall also furnish the name and telephone number of the appropriate contact person should the RVTD have any questions in relation to the information furnished herein.

DBE IDENTIFICATION AND INFORMATION FORM

Business Name and Address	Contact Name and Telephone Number	Percent of Total Contract	Description of Work to Be Performed	Race and Gender if known

(Failure to complete this form may render this bid non-responsive).

16.3 Debarment

CERTIFICATION OF PRIMARY PARTICIPANT REGARDING DEBARMENT, SUSPENSION, AND OTHER RESPONSIBILITY MATTERS

The Primary Participant _____ certifies to the best of its knowledge and belief, that it and its principals:

1. Are not presently debarred, suspended, proposed for debarment, declared ineligible or voluntarily excluded from covered transactions by any Federal department or RVTD.
2. Have not within a three-year period preceding this proposal been convicted of or had a civil judgment rendered against them for commission of fraud or a criminal offense in connection with obtaining, attempting to obtain, or performing a public (Federal, State or local) transaction or contract under a public transaction, - violation of Federal or State anti-trust statutes or commission of embezzlement, theft, forgery, bribery, falsification or destruction of records, making false statements, or receiving stolen property;
3. Are not presently indicted for or otherwise criminally or civilly charged by a governmental entity (Federal, State or local) with commission of any of the offenses enumerated in paragraph (2) of this certification; and
4. Have not, within three-year period preceding this application/proposal, had one or more public transactions (Federal, State or local) terminated for cause or default.

Where the CONTRACTOR is unable to certify to any of the statements in this certification, the participant shall attach an explanation to this certification.

CONTRACTOR (name) _____ CERTIFIES OR AFFIRMS THE TRUTHFULNESS AND ACCURACY OF THE CONTENTS OF THE STATEMENTS SUBMITTED ON OR WITH THIS CERTIFICATION AND UNDERSTANDS THAT THE PROVISIONS OF 31 U.S.C. SECTIONS 3801 ET. SEQ. ARE APPLICABLE THERETO.

Dun & Bradstreet Number: _____
(must be an active D&B number registered with the System For Award Management (www.sam.gov))

Date: _____ Authorized Official: _____

Signature: _____

16.4 Representation

CONTRACTOR'S REPRESENTATIONS

By the act of submitting a bid for the proposed Contract, the CONTRACTOR represents that:

- The CONTRACTOR and all SUB-CONTRACTORS they intend to use have carefully and thoroughly reviewed the Drawings, Specifications and other Documents and found them complete and free from ambiguities and sufficient for the purpose intended.
- The CONTRACTOR and all workers, employees and SUB-CONTRACTORS the CONTRACTOR intends to use shall follow all applicable codes and regulations, including but not limited to, the Americans with Disabilities Act (ADA) requirements. To that effect the successful CONTRACTOR shall be responsible to verify and construct the Project in compliance with the above stated regulations and coordinate any installations as required in order to meet the respective codes. In the event that the Project, or any part thereof, is found to be non-compliant, the successful CONTRACTOR shall be held solely responsible to remedy all found deficiencies at no additional cost to the Owner, or the Owner's employees or agents including Architects, Engineers or Consultants.
- The CONTRACTOR and all workers, employees and SUB-CONTRACTORS the CONTRACTOR intends to use are skilled and experienced in the type of construction represented by the Construction Contract Documents described in bid.
- The proposed figure is based solely upon the Construction Contract Documents and properly issued written Addenda and not upon any other written representation.
- Neither the CONTRACTOR nor any of the CONTRACTOR'S employees, agents, intended suppliers or SUB-CONTRACTORS have relied upon any verbal representations from the Owner, or the Owner's employees or agents including Architects, Engineers or Consultants in assembling the bid figure.

Acknowledged:

By: _____

For: _____

Date: _____

16.5 Certificate Regarding Lobbying

Project Name: CNG Compressor Skid Replacement #CNGCOMP26
Certification for Contracts, Grants, Loans, and Cooperative Agreements
(To be submitted with each bid or offer exceeding \$100,000)

The undersigned CONTRACTOR certifies, to the best of his or her knowledge and belief that:

(1) No Federal appropriated funds have been paid or will be paid, by or on behalf of the undersigned, to any person for influencing or attempting to influence an officer or employee of an agency, a Member of Congress, an officer or employee of Congress, or an employee of a Member of Congress in connection with the awarding of any Federal contract, the making of any Federal loan, the entering into of any cooperative agreement, and the extension, continuation, renewal, amendment, or modification of any Federal contract, grant, loan, or cooperative agreement.

(2) If any funds other than Federal appropriated funds have been paid or will be paid to any person for making lobbying contacts to an officer or employee of any agency, a Member of Congress, an officer or employee of Congress, or an employee of a Member of Congress in connection with this Federal contract, grant, loan, or cooperative agreement, the undersigned shall complete and submit Standard Form--LLL, "Disclosure Form to Report Lobbying," in accordance with its instructions [as amended by "Government-wide Guidance for New Restrictions on Lobbying," 61 Fed. Reg. 1413 (1/19/96)].

(3) The undersigned shall require that the language of this certification be included in the award documents for all subawards at all tiers (including subcontracts, subgrants, and contracts under grants, loans and cooperative agreements) and that all subrecipients shall certify and disclose accordingly.

This certification is a material representation of fact upon which reliance was placed when this transaction was made entered into. Submission of this certification is a prerequisite for making or entering into this transaction imposed by 31 U.S.C. § 1352 (as amended by the Lobbying Disclosure Act of 1995). Any person who fails to file the required shall be subject to a civil penalty of not less than \$10,000 and not more than \$100,000 for each such failure.

The CONTRACTOR, _____, certifies or affirms the truthfulness and accuracy of each statement of its certification and disclosure, if any. In addition, the CONTRACTOR understands and agrees that the provisions of 31 U.S.C. 3801, et. seq., apply to this certification and disclosure, if any.

Acknowledged:

_____ Signature of CONTRACTOR'S Authorized Official

_____ Name and Title of CONTRACTOR'S Authorized Official

_____ Date

16.6 Buy America

Project Name: CNG Compressor Skid Replacement Project # CNGCOMP26

BUY AMERICA

49 U.S.C. 5323(j) 49 C.F.R. part 661

The CONTRACTOR agrees to comply with 49 U.S.C. 5323(j) and 49 C.F.R. part 661, which provide that Federal funds may not be obligated unless all steel, iron, and **manufactured products** used in FTA funded projects are produced in the United States, unless a waiver has been granted by FTA or the product is subject to a general waiver. General waivers are listed in 49 C.F.R. § 661.7. Separate requirements for rolling stock are set out at 49 U.S.C. 5323(j)(2)(C) and 49 C.F.R. § 661.11.

The bidder or offeror must submit to RVTD the appropriate Buy America certification below with its bid or offer. Bids or offers that are not accompanied by a completed Buy America certification will be rejected as nonresponsive.

In accordance with 49 C.F.R. § 661.6, for the procurement of steel, iron or manufactured products, use the certifications below.

Certificate of Compliance with Buy America Requirements

The bidder or offeror hereby certifies that it will comply with the requirements of 49 U.S.C. 5323(j)(1), and the applicable regulations in 49 C.F.R. part 661.

Date: _____

Signature: _____

Company: _____

Name: _____

Title: _____

Certificate of Non-Compliance with Buy America Requirements

The bidder or offeror hereby certifies that it cannot comply with the requirements of 49 U.S.C. 5323(j), but it may qualify for an exception to the requirement pursuant to 49 U.S.C. 5323(j)(2), as amended, and the applicable regulations in 49 C.F.R. § 661.7.

Date: _____

Signature: _____

Company: _____

Name: _____

Title: _____

16.7 Receipt of Addenda

ADDENDA RECEIVED:

Addendum No. _____ Date Received: _____

Addendum No. _____ Date Received: _____

Addendum No. _____ Date Received: _____

Addendum No. _____ Date Received: _____

Addendum No. _____ Date Received: _____

Addendum No. _____ Date Received: _____

Addendum No. _____ Date Received: _____

Addendum No. _____ Date Received: _____

Addendum No. _____ Date Received: _____

Addendum No. _____ Date Received: _____

If no addendum was received, write "None Received": _____

Date: _____

Representative Signature: _____

Printed Name: _____

Company: _____

Section 17. Federally Required and Other Model Contract Clauses

ACCESS TO RECORDS AND REPORTS

49 U.S.C. § 5325(g) 2 C.F.R. § 200.333 49 C.F.R. part 633

- a. **Record Retention.** The Contractor will retain, and will require its subcontractors of all tiers to retain, complete and readily accessible records related in whole or in part to the contract, including, but not limited to, data, documents, reports, statistics, sub-agreements, leases, subcontracts, arrangements, other third party agreements of any type, and supporting materials related to those records.
- b. **Retention Period.** The Contractor agrees to comply with the record retention requirements in accordance with 2 C.F.R. § 200.333. The Contractor shall maintain all books, records, accounts and reports required under this Contract for a period of at not less than three (3) years after the date of termination or expiration of this Contract, except in the event of litigation or settlement of claims arising from the performance of this Contract, in which case records shall be maintained until the disposition of all such litigation, appeals, claims or exceptions related thereto.
- c. **Access to Records.** The Contractor agrees to provide sufficient access to FTA and its contractors to inspect and audit records and information related to performance of this contract as reasonably may be required.
- d. **Access to the Sites of Performance.** The Contractor agrees to permit FTA and its contractors access to the sites of performance under this contract as reasonably may be required.

BUY AMERICA

49 U.S.C. 5323(j) 49 C.F.R. part 661

The contractor agrees to comply with 49 U.S.C. 5323(j) and 49 C.F.R. part 661, which provide that Federal funds may not be obligated unless all steel, iron, and manufactured products used in FTA funded projects are produced in the United States, unless a waiver has been granted by FTA or the product is subject to a general waiver. General waivers are listed in 49 C.F.R. § 661.7. Separate requirements for rolling stock are set out at 49 U.S.C. 5323(j)(2)(C) and 49 C.F.R. § 661.11.

CARGO PREFERENCE – Use of United States-Flag Vessels

46 U.S.C. § 55305 46 C.F.R. part 381

The contractor agrees:

- a. to use privately owned United States-Flag commercial vessels to ship at least 50 percent of the gross tonnage (computed separately for dry bulk carriers, dry cargo liners, and tankers) involved, whenever shipping any equipment, material, or commodities pursuant to the underlying contract to the extent such vessels are available at fair and reasonable rates for United States-Flag commercial vessels;

- b. to furnish within 20 working days following the date of loading for shipments originating within the United States or within 30 working days following the date of loading for shipments originating outside the United States, a legible copy of a rated, "on-board" commercial ocean bill-of-lading in English for each shipment of cargo described in the preceding paragraph to the Division of National Cargo, Office of Market Development, Maritime Administration, Washington, DC 20590 and to the FTA recipient (through the contractor in the case of a subcontractor's bill-of-lading.); and
- c. to include these requirements in all subcontracts issued pursuant to this contract when the subcontract may involve the transport of equipment, material, or commodities by ocean vessel.

CLEAN AIR ACT AND FEDERAL WATER POLLUTION CONTROL ACT

42 U.S.C. §§ 7401 – 7671q 33 U.S.C. §§ 1251-1387 2 C.F.R. part 200, Appendix II (G)

The Contractor agrees:

- 1) It will not use any violating facilities;
- 2) It will report the use of facilities placed on or likely to be placed on the U.S. EPA "List of Violating Facilities;"
- 3) It will report violations of use of prohibited facilities to FTA; and
- 4) It will comply with the inspection and other requirements of the Clean Air Act, as amended, (42 U.S.C. §§ 7401 – 7671q); and the Federal Water Pollution Control Act as amended, (33 U.S.C. §§ 1251-1387).

PREVAILING WAGE AND ANTI-KICKBACK

40 U.S.C. 276

For all prime construction, alteration or repair contracts in excess of \$2,000 awarded by FTA, the Contractor shall comply with the Davis-Bacon Act and the Copeland "Anti-Kickback" Act. Under 49 U.S.C. § 5333(a), prevailing wage protections apply to laborers and mechanics employed on FTA assisted construction, alteration, or repair projects. The Contractor will comply with the Davis-Bacon Act, 40 U.S.C. §§ 3141-3144, and 3146-3148 as supplemented by DOL regulations at 29 C.F.R. part 5, "Labor Standards Provisions Applicable to Contracts Governing Federally Financed and Assisted Construction." In accordance with the statute, the Contractor shall pay wages to laborers and mechanics at a rate not less than the prevailing wages specified in a wage determination made by the Secretary of Labor. In addition, the Contractor agrees to pay wages not less than once a week. The Contractor shall also comply with the Copeland "Anti-Kickback" Act (40 U.S.C. § 3145), as supplemented by DOL regulations at 29 C.F.R. part 3, "Contractors and Subcontractors on Public Building or Public Work Financed in Whole or in part by Loans or Grants from the United States." The Contractor is prohibited from inducing, by any means, any person employed in the construction, completion, or repair of public work, to give up any part of the compensation to which he or she is otherwise entitled.

CONTRACT WORK HOURS AND SAFETY STANDARDS

For all contracts in excess of \$100,000 that involve the employment of mechanics or laborers, the Contractor shall comply with the Contract Work Hours and Safety Standards Act (40 U.S.C. §§ 3701- 3708), as supplemented by the DOL regulations at 29 C.F.R. part 5. Under 40 U.S.C. § 3702 of the Act, the Contractor shall compute the wages of every mechanic and laborer, including watchmen and guards, on the basis of a standard work week of 40 hours. Work in excess of the standard work week is permissible provided that the worker is compensated at a rate of not less than one and a half times the basic rate of pay for all hours worked in excess of 40 hours in the work week. The requirements of 40 U.S.C. § 3704 are applicable to construction work and provide that no laborer or mechanic be required to work in surroundings or under working conditions which are unsanitary, hazardous or dangerous. These requirements do not apply to the purchase of supplies or materials or articles ordinarily available on the open market, or to contracts for transportation or transmission of intelligence.

In the event of any violation of the clause set forth herein, the Contractor and any subcontractor responsible therefore shall be liable for the unpaid wages. In addition, the Contractor and subcontractor shall be liable to the United States (in the case of work done under contract for the District of Columbia or a territory, to such District or to such territory), for liquidated damages. Such liquidated damages shall be computed with respect to each individual laborer or mechanic, including watchmen and guards, employed in violation of this clause in the sum of \$10 for each calendar day on which such individual was required or permitted to work in excess of the standard workweek of forty hours without payment of the overtime wages required by this clause.

The FTA shall upon its own action or upon written request of an authorized representative of the Department of Labor withhold or cause to be withheld, from any moneys payable on account of work performed by the Contractor or subcontractor under any such contract or any other Federal contract with the same prime Contractor, or any other federally-assisted contract subject to the Contract Work Hours and Safety Standards Act, which is held by the same prime Contractor, such sums as may be determined to be necessary to satisfy any liabilities of such Contractor or subcontractor for unpaid wages and liquidated damages as provided in this section.

The Contractor or subcontractor shall insert in any subcontracts the clauses set forth in this section and also a clause requiring the subcontractors to include these clauses in any lower tier subcontracts. The prime Contractor shall be responsible for compliance by any subcontractor or lower tier subcontractor with the clauses set forth in this agreement.

Contract Work Hours and Safety Standards for Awards Non Involving Construction

The Contractor shall comply with all federal laws, regulations, and requirements providing wage and hour protections for non-construction employees, in accordance with 40 U.S.C. § 3702, Contract Work Hours and Safety Standards Act, and other relevant parts of that Act, 40 U.S.C. § 3701 et seq., and U.S. DOL regulations, "Labor Standards Provisions Applicable to Contracts Covering Federally Financed and Assisted Construction (also Labor Standards Provisions Applicable to Non-construction Contracts Subject to the Contract Work Hours and Safety Standards Act)," 29 C.F.R. part 5.

The Contractor shall maintain payrolls and basic payroll records during the course of the work and shall preserve them for a period of three (3) years from the completion of the contract for all laborers and mechanics, including guards and watchmen, working on the contract. Such records shall contain the name and address of each such employee, social security number, correct classifications, hourly rates of wages paid, daily and weekly number of hours worked, deductions made, and actual wages paid.

Such records maintained under this paragraph shall be made available by the Contractor for inspection, copying, or transcription by authorized representatives of the FTA and the Department of Labor, and the Contractor will permit such representatives to interview employees during working hours on the job.

The contractor shall require the inclusion of the language of this clause within subcontracts of all tiers.

CIVIL RIGHTS LAWS AND REGULATIONS

28 CFR Part 42

The AGENCY is an Equal Opportunity Employer. As such, the AGENCY agrees to comply with all applicable Federal civil rights laws and implementing regulations. Apart from inconsistent requirements imposed by Federal laws or regulations, the AGENCY agrees to comply with the requirements of 49 U.S.C. § 5323(h) (3) by not using any Federal assistance awarded by FTA to support procurements using exclusionary or discriminatory specifications.

Under this Agreement, the Contractor shall at all times comply with the following requirements and shall include these requirements in each subcontract entered into as part thereof.

1. **Nondiscrimination.** In accordance with Federal transit law at 49 U.S.C. § 5332, the Contractor agrees that it will not discriminate against any employee or applicant for employment because of race, color, religion, national origin, sex, disability, or age. In addition, the Contractor agrees to comply with applicable Federal implementing regulations and other implementing requirements FTA may issue.
2. **Race, Color, Religion, National Origin, Sex.** In accordance with Title VII of the Civil Rights Act, as amended, 42 U.S.C. § 2000e et seq., and Federal transit laws at 49 U.S.C. § 5332, the Contractor agrees to comply with all applicable equal employment opportunity requirements of U.S. Department of Labor (U.S. DOL) regulations, "Office of Federal Contract Compliance Programs, Equal Employment Opportunity, Department of Labor," 41 C.F.R. chapter 60, and Executive Order No. 11246, "Equal Employment Opportunity in Federal Employment," September 24, 1965, 42 U.S.C. § 2000e note, as amended by any later Executive Order that amends or supersedes it, referenced in 42 U.S.C. § 2000e note. The Contractor agrees to take affirmative action to ensure that applicants are employed, and that employees are treated during employment, without regard to their race, color, religion, national origin, or sex (including sexual orientation and gender identity). Such action shall include, but not be limited to, the following: employment, promotion, demotion or transfer, recruitment or recruitment advertising, layoff or termination; rates of pay or other forms of compensation; and selection for training, including apprenticeship. In addition, the Contractor agrees to comply with any implementing requirements FTA may issue.
3. **Age.** In accordance with the Age Discrimination in Employment Act, 29 U.S.C. §§ 621- 634, U.S. Equal Employment Opportunity Commission (U.S. EEOC) regulations, "Age Discrimination in Employment Act," 29 C.F.R. part 1625, the Age Discrimination Act of 1975, as amended, 42 U.S.C. § 6101 et seq.,

U.S. Health and Human Services regulations, "Nondiscrimination on the Basis of Age in Programs or Activities Receiving Federal Financial Assistance," 45 C.F.R. part 90, and Federal transit law at 49 U.S.C. § 5332, the Contractor agrees to refrain from discrimination against present and prospective employees for reason of age. In addition, the Contractor agrees to comply with any implementing requirements FTA may issue.

4. Disabilities. In accordance with section 504 of the Rehabilitation Act of 1973, as amended, 29 U.S.C. § 794, the Americans with Disabilities Act of 1990, as amended, 42 U.S.C. § 12101 et seq., the Architectural Barriers Act of 1968, as amended, 42 U.S.C. § 4151 et seq., and Federal transit law at 49 U.S.C. § 5332, the Contractor agrees that it will not discriminate against individuals on the basis of disability. In addition, the Contractor agrees to comply with any implementing requirements FTA may issue.

DISADVANTAGED BUSINESS ENTERPRISE (DBE)

49 C.F.R. part 26

For all DOT-assisted contracts, each FTA recipient must include assurances that third party contractors will comply with the DBE program requirements of 49 C.F.R. part 26, when applicable. The following contract clause is required in all DOT-assisted prime and subcontracts:

The contractor, subrecipient or subcontractor shall not discriminate on the basis of race, color, national origin, or sex in the performance of this contract. The contractor shall carry out applicable requirements of 49 C.F.R. part 26 in the award and administration of DOT-assisted contracts. Failure by the contractor to carry out these requirements is a material breach of this contract, which may result in the termination of this contract or such other remedy as the recipient deems appropriate, which may include, but is not limited to:

- (1) Withholding monthly progress payments;
- (2) Assessing sanctions;
- (3) Liquidated damages; and/or
- (4) Disqualifying the contractor from future bidding as non-responsible. 49 C.F.R. § 26.13(b).

Further, recipients must establish a contract clause to require prime contractors to pay subcontractors for satisfactory performance of their contracts no later than 30 days from receipt of each payment the recipient makes to the prime contractor. 49 C.F.R. § 26.29(a). Finally, for contracts with defined DBE contract goals, each FTA recipient must include in each prime contract a provision stating that the contractor shall utilize the specific DBEs listed unless the contractor obtains the recipient's written consent; and that, unless the recipient's consent is provided, the contractor shall not be entitled to any payment for work or material unless it is performed or supplied by the listed DBE. 49 C.F.R. § 26.53(f) (1).

As an additional resource, recipients can draw on the following language for inclusion in their federally funded procurements.

Overview

It is the policy of the AGENCY and the United States Department of Transportation (“DOT”) that Disadvantaged Business Enterprises (“DBE’s”), as defined herein and in the Federal regulations published at 49 C.F.R. part 26, shall have an equal opportunity to participate in DOT-assisted contracts. It is also the policy of the AGENCY to:

1. Ensure nondiscrimination in the award and administration of DOT-assisted contracts;
2. Create a level playing field on which DBE’s can compete fairly for DOT-assisted contracts;
3. Ensure that the DBE program is narrowly tailored in accordance with applicable law;
4. Ensure that only firms that fully meet 49 C.F.R. part 26 eligibility standards are permitted to participate as DBE’s;
5. Help remove barriers to the participation of DBEs in DOT assisted contracts;
6. To promote the use of DBEs in all types of federally assisted contracts and procurement activities; and
7. Assist in the development of firms that can compete successfully in the marketplace outside the DBE program.

This Contract is subject to 49 C.F.R. part 26. Therefore, the Contractor must satisfy the requirements for DBE participation as set forth herein. These requirements are in addition to all other equal opportunity employment requirements of this Contract. The AGENCY shall make all determinations with regard to whether or not a Bidder/Offeror is in compliance with the requirements stated herein. In assessing compliance, the AGENCY may consider during its review of the Bidder/Offeror’s submission package, the Bidder/Offeror’s documented history of non-compliance with DBE requirements on previous contracts with the AGENCY.

Contract Assurance

The Contractor, subrecipient or subcontractor shall not discriminate on the basis of race, color, national origin, or sex in the performance of this Contract. The Contractor shall carry out applicable requirements of 49 C.F.R. part 26 in the award and administration of DOT-assisted contracts. Failure by the Contractor to carry out these requirements is a material breach of this Contract, which may result in the termination of this Contract or such other remedy as the AGENCY deems appropriate.

ENERGY CONSERVATION

42 U.S.C. 6321 et seq. 49 C.F.R. part 622, subpart C

The contractor agrees to comply with mandatory standards and policies relating to energy efficiency, which are contained in the state energy conservation plan issued in compliance with the Energy Policy and Conservation Act.

LOBBYING RESTRICTIONS

31 U.S.C. § 1352 2 C.F.R. § 200.450 2 C.F.R. part 200 appendix II (J) 49 C.F.R. part 20

Contractor certifies to the best of his or her knowledge and belief, that:

1. No Federal appropriated funds have been paid or will be paid, by or on behalf of the undersigned, to any person for influencing or attempting to influence an officer or employee of an agency, a Member of Congress, an officer or employee of Congress, or an employee of a Member of Congress in connection with the awarding of any Federal contract, the making of any Federal grant, the making of any Federal loan, the entering into of any cooperative agreement, and the extension, continuation, renewal, amendment, or modification of any Federal contract, grant, loan, or cooperative agreement.
2. If any funds other than Federal appropriated funds have been paid or will be paid to any person for influencing or attempting to influence an officer or employee of any agency, a Member of Congress, an officer or employee of Congress, or an employee of a Member of Congress in connection with this Federal contract, grant, loan, or cooperative agreement, the undersigned shall complete and submit Standard Form-LLL, "Disclosure Form to Report Lobbying," in accordance with its instructions.

FLY AMERICA

49 U.S.C. § 40118 41 C.F.R. part 301-10 48 C.F.R. part 47.4

- a) Definitions. As used in this clause—

"International air transportation" means transportation by air between a place in the United States and a place outside the United States or between two places both of which are outside the United States.

"United States" means the 50 States, the District of Columbia, and outlying areas.

"U.S.-flag air carrier" means an air carrier holding a certificate under 49 U.S.C. Chapter 411.

- b) When Federal funds are used to fund travel, Section 5 of the International Air Transportation Fair Competitive Practices Act of 1974 (49 U.S.C. 40118) (Fly America Act) requires contractors, recipients, and others use U.S.-flag air carriers for U.S. Government-financed international air transportation of personnel (and their personal effects) or property, to the extent that service by those carriers is available. It requires the Comptroller General of the United States, in the absence of satisfactory proof of the necessity for foreign-flag air transportation, to disallow expenditures from funds, appropriated or otherwise established for the account of the United States, for international air transportation secured aboard a foreign-flag air carrier if a U.S.-flag air carrier is available to provide such services.
- c) If available, the Contractor, in performing work under this contract, shall use U.S.-flag carriers for international air transportation of personnel (and their personal effects) or property.
- d) In the event that the Contractor selects a carrier other than a U.S.-flag air carrier for international air transportation, the Contractor shall include a statement on vouchers involving such transportation essentially as follows:

Statement of Unavailability of U.S. – Flag Air Carriers

International air transportation of persons (and their personal effects) or property by U.S.-flag air carrier was not available or it was necessary to use foreign-flag air carrier service for the following reasons. See FAR § 47.403.

- e) The Contractor shall include the substance of this clause, including this paragraph (e), in each subcontract or purchase under this contract that may involve international air transportation.

BONDING REQUIREMENTS

2 C.F.R. § 200.325 31 C.F.R. part 223

Bid Guarantee

Bidders shall furnish a bid guaranty in the form of a bid bond, or certified treasurer's or cashier's check issued by a responsible bank or trust company, made payable to Rogue Valley Transportation District (RVTD). The amount of such guaranty shall be equal to (five percent) 5% of the total project price. In submitting this bid, it is understood and agreed by bidder that the RVTD reserves the right to reject any and all bids, or part of any bid, and it is agreed that the Bid may not be withdrawn for a period of [90] days subsequent to the opening of bids, without the written consent of RVTD. It is also understood and agreed that if the undersigned bidder should withdraw any part or all of his bid within [90] days after the bid opening without the written consent of the RVTD, or refuse or be unable to enter into this Contract as provided above, or refuse or be unable to furnish adequate and acceptable Performance and Payment Bonds, or refuse or be unable to furnish adequate and acceptable insurance, as provided above, it shall forfeit its bid guaranty to the extent RVTD'S damages occasioned by such withdrawal, or refusal, or inability to enter into an agreement, or provide adequate security thereof. It is further understood and agreed that to the extent the defaulting bidder's bid guaranty shall prove inadequate to fully recompense RVTD for the damages occasioned by default, then the undersigned bidder agrees to indemnify RVTD and pay over to RVTD the difference between the bid guarantee and RVTD'S total damages so as to make RVTD whole. The undersigned understands that any material alteration of any of the above or any of the material contained herein, other than that requested will render the bid unresponsive.

Performance Guarantee

A Performance Guarantee in the amount of 100% of the Contract value is required by the RVTD to ensure faithful performance of the Contract. Either a Performance Bond or an Irrevocable Stand-By Letter of Credit shall be provided by the Contractor and shall remain in full force for the term of the Agreement. The successful Bidder shall certify that it will provide the requisite Performance Guarantee to the RVTD within ten (10) business days from Contract execution. The RVTD requires all Performance Bonds to be provided by a fully qualified surety company acceptable to the RVTD and listed as a company currently authorized under 31 C.F.R. part 22 as possessing a Certificate of Authority as described hereunder. RVTD may require additional performance bond protection when the contract price is increased. The increase in protection shall generally equal 100 percent of the increase in contract price. The RVTD may secure additional protection by directing the Contractor to increase the amount of the existing bond or to obtain an additional bond. If the Bidder chooses to provide a Letter of Credit as its Performance Guarantee, the Bidder shall furnish with its bid, certification that an Irrevocable Stand-By Letter of Credit will be furnished should the Bidder become the successful Contractor. The Bidder shall also provide a statement from the banking institution certifying that an Irrevocable Stand-By

Letter of Credit for the action will be provided if the Contract is awarded to the Bidder. The Irrevocable Stand-By Letter of Credit will only be accepted by the RVTD if:

1. A bank in good standing issues it. The RVTD will not accept a Letter of Credit from an entity other than a bank.
2. It is in writing and signed by the issuing bank.
3. It conspicuously states that it is an irrevocable, non-transferable, "standby" Letter of Credit.
4. The RVTD is identified as the Beneficiary.
5. It is in an amount equal to **100%** of the Contract value. This amount must be in U.S. dollars.
6. The effective date of the Letter of Credit is the same as the effective date of the Contract
7. The expiration date of the Letter of Credit coincides with the term of this Agreement.
8. It indicates that it is being issued in order to support the obligation of the Contractor to perform under the Contract. It must specifically reference the Contract between the RVTD and the Contractor the work stipulated herein.

The issuing bank's obligation to pay will arise upon the presentation of the original Letter of Credit and a certificate and draft (similar to the attached forms contained in Sections X and Y) to the issuing bank's representative at a location and time to be determined by the parties. This documentation will indicate that the Contractor is in default under the Contract.

Payment Bonds

A Labor and Materials Payment Bond equal to the full value of the contract must be furnished by the contractor to RVTD as security for payment by the Contractor and subcontractors for labor, materials, and rental of equipment. The bond may be issued by a fully qualified surety company acceptable to (RVTD) and listed as a company currently authorized under 31 C.F.R. part 223 as possessing a Certificate of Authority as described thereunder.

GOVERNMENT-WIDE DEBARMENT AND SUSPENSION

2 C.F.R. part 180 2 C.F.R part 1200 2 C.F.R. § 200.213 2 C.F.R. part 200 Appendix II (I) Executive

The Contractor shall comply and facilitate compliance with U.S. DOT regulations, "Nonprocurement Suspension and Debarment," 2 C.F.R. part 1200, which adopts and supplements the U.S. Office of Management and Budget (U.S. OMB) "Guidelines to Agencies on Governmentwide Debarment and Suspension (Nonprocurement)," 2 C.F.R. part 180. These provisions apply to each contract at any tier of \$25,000 or more, and to each contract at any tier for a federally required audit (irrespective of the contract amount), and to each contract at any tier that must be approved by an FTA official irrespective of the contract amount. As such, the Contractor shall verify that its principals, affiliates, and subcontractors are eligible to participate in this federally funded contract and are not presently declared by any Federal department or agency to be:

- a) Debarred from participation in any federally assisted Award;
- b) Suspended from participation in any federally assisted Award;
- c) Proposed for debarment from participation in any federally assisted Award;
- d) Declared ineligible to participate in any federally assisted Award;
- e) Voluntarily excluded from participation in any federally assisted Award; or
- f) Disqualified from participation in any federally assisted Award.

By signing and submitting its bid or proposal, the bidder or proposer certifies as follows:

The certification in this clause is a material representation of fact relied upon by the AGENCY. If it is later determined by the AGENCY that the bidder or proposer knowingly rendered an erroneous certification, in addition to remedies available to the AGENCY, the Federal Government may pursue available remedies, including but not limited to suspension and/or debarment. The bidder or proposer agrees to comply with the requirements of 2 C.F.R. part 180, subpart C, as supplemented by 2 C.F.R. part 1200, while this offer is valid and throughout the period of any contract that may arise from this offer. The bidder or proposer further agrees to include a provision requiring such compliance in its lower tier covered transactions.

NO GOVERNMENT OBLIGATION TO THIRD PARTIES

The RVTD and Contractor acknowledge and agree that, notwithstanding any concurrence by the Federal Government in or approval of the solicitation or award of the underlying Contract, absent the express written consent by the Federal Government, the Federal Government is not a party to this Contract and shall not be subject to any obligations or liabilities to the RVTD, Contractor or any other party (whether or not a party to that contract) pertaining to any matter resulting from the underlying Contract. The Contractor agrees to include the above clause in each subcontract financed in whole or in part with Federal assistance provided by the FTA. It is further agreed that the clause shall not be modified, except to identify the subcontractor who will be subject to its provisions.

PROGRAM FRAUD AND FALSE OR FRAUDULENT STATEMENTS AND RELATED ACTS

49 U.S.C. § 5323(l) (1) 31 U.S.C. §§ 3801-3812 18 U.S.C. § 1001 49 C.F.R. part 31

The Contractor acknowledges that the provisions of the Program Fraud Civil Remedies Act of 1986, as amended, 31 U.S.C. § 3801 et seq. and U.S. DOT regulations, "Program Fraud Civil Remedies," 49 C.F.R. part 31, apply to its actions pertaining to this Project. Upon execution of the underlying contract, the Contractor certifies or affirms the truthfulness and accuracy of any statement it has made, it makes, it may make, or causes to be made, pertaining to the underlying contract or the FTA assisted project for which this contract work is being performed. In addition to other penalties that may be applicable, the Contractor further acknowledges that if it makes, or causes to be made, a false, fictitious, or fraudulent claim, statement, submission, or certification, the Federal Government reserves the right to impose the penalties of the Program Fraud Civil Remedies Act of 1986 on the Contractor to the extent the Federal Government deems appropriate.

The Contractor also acknowledges that if it makes, or causes to be made, a false, fictitious, or fraudulent claim, statement, submission, or certification to the Federal Government under a contract connected with a project that is financed in whole or in part with Federal assistance originally awarded by FTA under the authority of 49 U.S.C. chapter 53, the Government reserves the right to impose the penalties of 18 U.S.C. § 1001 and 49 U.S.C. § 5323(l) on the Contractor, to the extent the Federal Government deems appropriate.

The Contractor agrees to include the above two clauses in each subcontract financed in whole or in part with Federal assistance provided by FTA. It is further agreed that the clauses shall not be modified, except to identify the subcontractor who will be subject to the provisions.

RECYCLED PRODUCTS

42 U.S.C. § 6962 40 C.F.R. part 247 2 C.F.R. part § 200.322

Recovered Materials

The Contractor agrees to provide a preference for those products and services that conserve natural resources, protect the environment, and are energy efficient by complying with and facilitating compliance with Section 6002 of the Resource Conservation and Recovery Act, as amended, 42 U.S.C. § 6962, and U.S. Environmental Protection Agency (U.S. EPA), “Comprehensive Procurement Guideline for Products Containing Recovered Materials,” 40 C.F.R. part 247.

SAFE OPERATION OF MOTOR VEHICLES

23 U.S.C. part 402 Executive Order No. 13043 Executive Order No. 13513 U.S. DOT Order No. 3902.10

The Contractor is encouraged to adopt and promote on-the-job seat belt use policies and programs for its employees and other personnel that operate company-owned vehicles, company rented vehicles, or personally operated vehicles. The terms “company-owned” and “company-leased” refer to vehicles owned or leased either by the Contractor or AGENCY.

Distracted Driving

The Contractor agrees to adopt and enforce workplace safety policies to decrease crashes caused by distracted drivers, including policies to ban text messaging while using an electronic device supplied by an employer, and driving a vehicle the driver owns or rents, a vehicle Contractor owns, leases, or rents, or a privately-owned vehicle when on official business in connection with the work performed under this agreement.

SEISMIC SAFETY

42 U.S.C. 7701 et seq. 49 C.F.R. part 41 Executive Order (E.O.) 12699

The contractor agrees that any new building or addition to an existing building will be designed and constructed in accordance with the standards for Seismic Safety required in Department of Transportation (DOT) Seismic Safety Regulations 49 C.F.R. part 41 and will certify to compliance to the extent required by the regulation. The contractor also agrees to ensure that all work performed under this contract, including work performed by a subcontractor, is in compliance with the standards required by the Seismic Safety regulations and the certification of compliance issued on the project.

FEDERAL CHANGES

Contractor shall at all times comply with all applicable FTA regulations, policies, procedures and directives, including without limitation those listed directly or by reference in the FTA Master Agreement between the Rogue Valley Transportation District and the FTA, as they may be amended or promulgated from time to time during the term of the Contract. Contractor's failure to so comply shall constitute a material breach of the Contract.

TERMINATION

2 C.F.R. § 200.339 2 C.F.R. part 200, Appendix II (B)

Termination for Convenience (General Provision)

RVTD may terminate this contract, in whole or in part, at any time by written notice to the CONTRACTOR if deemed in the RVTD's best interest. The CONTRACTOR shall be compensated for allowable costs, including close-out expenses and profit on work performed up to the termination date. Upon termination, the CONTRACTOR shall promptly submit a termination claim for payment and account for any RVTD property in its possession as directed by the RVTD.

Termination for Default (Breach or Cause)

If the CONTRACTOR fails to deliver supplies or perform services in accordance with contract terms or otherwise breaches the contract, the RVTD may terminate for default by written notice specifying the breach. The CONTRACTOR will only be paid for supplies delivered and accepted or services performed as per the contract.

If the RVTD determines the CONTRACTOR'S nonperformance was excusable (e.g., due to strike, fire, flood, or other uncontrollable events), it may allow work to continue under a revised schedule or treat the termination as one for convenience.

Termination for Convenience (Professional or Transit Service Contracts)

RVTD, by written notice, may terminate this contract, in whole or in part, when it is in RVTD's interest. If this contract is terminated, RVTD shall be liable only for payment under the payment provisions of this contract for services rendered before the effective date of termination.

Termination for Default (Supplies and Service)

If the CONTRACTOR fails to deliver supplies or to perform the services within the time specified in this contract or any extension, or if the CONTRACTOR fails to comply with any other provisions of this contract, RVTD may terminate this contract for default. RVTD shall terminate by delivering to the CONTRACTOR a Notice of Termination specifying the nature of the default. The CONTRACTOR will only be paid the contract price for supplies delivered and accepted, or services performed in accordance with the manner or performance set forth in this contract.

If, after termination for failure to fulfill contract obligations, it is determined that the CONTRACTOR was not in default, the rights and obligations of the parties shall be the same as if the termination had been issued for the convenience of RVTD.

Disputes

RVTD and the CONTRACTOR intend to resolve all disputes under this Agreement to the best of their abilities in an informal manner. To accomplish this end, the parties will use an Alternative Dispute Resolution process to resolve disputes in a manner designed to avoid litigation. In general, the parties contemplate that the Alternative Dispute Resolution process will include, at a minimum, an attempt to resolve disputes through

communications between their staffs, and, if resolution is not reached at that level, a procedure for review and action on such disputes by appropriate management level officials within RVTD and the CONTRACTOR'S organization.

In the event that a resolution of the dispute is not mutually agreed upon, the parties can agree to mediate the dispute or proceed with litigation. Notwithstanding any provision of this section, or any other provision of this Contract, it is expressly agreed and understood that any court proceeding arising out of a dispute under the Contract shall be heard by a Court de novo and the court shall not be limited in such proceeding to the issue of whether the Authority acted in an arbitrary, capricious or grossly erroneous manner. Pending final settlement of any dispute, the parties shall proceed diligently with the performance of the Contract, and in accordance with RVTD's direction or decisions made thereof.

Performance during Dispute

Unless otherwise directed by RVTD, CONTRACTOR shall continue performance under this Contract while matters in dispute are being resolved.

Opportunity to Cure

For terminations due to breach or default, RVTD may provide the CONTRACTOR a specified period to remedy the breach. The termination notice will outline the cure period and relevant conditions. If the CONTRACTOR fails to resolve the issue within the provided timeframe, RVTD may terminate the contract and pursue available remedies.

Notice: Termination shall be affected by serving a written notice of termination on the CONTRACTOR setting forth the manner in which CONTRACTOR is in default. Service shall be obtained by personal delivery or delivery by mail, registered or certified, postage prepaid with return receipt requested and addressed to CONTRACTOR at the most recent address provided by CONTRACTOR.

RVTD Options: In addition to any and all other remedies at law or in equity that are available to RVTD, default by CONTRACTOR may result in the occurrence of one or more of the following:

- a) RVTD may complete such contract without further liability to CONTRACTOR for compensation for any labor, supplies or materials furnished by CONTRACTOR under the contract; and
- b) To the extent applicable, RVTD may direct CONTRACTOR to remove any equipment delivered and/or installed by CONTRACTOR and to refund to RVTD any amounts paid by RVTD to the CONTRACTOR, and RVTD shall have no further liability to the CONTRACTOR; and
- c) RVTD may contract to acquire supplies or services similar to those terminated and CONTRACTOR shall remain liable to RVTD for any difference in the total costs and expenses incurred by RVTD.

Compensation and Liability:

CONTRACTOR will only be paid the contract price for supplies delivered and accepted, or services performed in accordance with the manner of performance bargained and set forth in the contract. In addition to any other available remedies, CONTRACTOR, and to the extent applicable, CONTRACTOR'S sureties shall be liable to RVTD for all costs, loss or damage incurred for supplies or services to complete the contract.

Termination of Subcontracts

The CONTRACTOR shall terminate any subcontracts as directed by RVTD. RVTD is not liable for obligations incurred by the CONTRACTOR after the termination date.

VIOLATION AND BREACH OF CONTRACT

2 C.F.R. § 200.326 2 C.F.R. part 200, Appendix II (A)

Rights and Remedies of the AGENCY

1. The right to take over and complete the work or any part thereof as agency for and at the expense of the Contractor, either directly or through other contractors;
2. The right to cancel this Contract as to any or all of the work yet to be performed;
3. The right to specific performance, an injunction or any other appropriate equitable remedy; and
4. The right to money damages.

For purposes of this Contract, breach shall include (AGENCY to define).

Rights and Remedies of Contractor

Inasmuch as the Contractor can be adequately compensated by money damages for any breach of this Contract, which may be committed by the AGENCY, the Contractor expressly agrees that no default, act or omission of the AGENCY shall constitute a material breach of this Contract, entitling Contractor to cancel or rescind the Contract (unless the AGENCY directs Contractor to do so) or to suspend or abandon performance.

Remedies

Substantial failure of the Contractor to complete the Project in accordance with the terms of this Agreement will be a default of this Agreement. In the event of a default, the AGENCY will have all remedies in law and equity, including the right to specific performance, without further assistance, and the rights to termination or suspension as provided herein. The Contractor recognizes that in the event of a breach of this Agreement by the Contractor before the AGENCY takes action contemplated herein, the AGENCY will provide the Contractor with sixty (60) days written notice that the AGENCY considers that such a breach has occurred and will provide the Contractor a reasonable period of time to respond and to take necessary corrective action.

Disputes

Example 1: Disputes arising in the performance of this Contract that are not resolved by agreement of the parties shall be decided in writing by the authorized representative of AGENCY's [title of employee]. This decision shall be final and conclusive unless within [10] days from the date of receipt of its copy, the Contractor mails or otherwise furnishes a written appeal to the [title of employee]. In connection with any such appeal, the Contractor shall be afforded an opportunity to be heard and to offer evidence in support of its position. The decision of the [title of employee] shall be binding upon the Contractor and the Contractor shall abide by the decision.

Example 2: The AGENCY and the Contractor intend to resolve all disputes under this Agreement to the best of their abilities in an informal manner. To accomplish this end, the parties will use an Alternative Dispute Resolution process to resolve disputes in a manner designed to avoid litigation. In general, the parties contemplate that the Alternative Dispute Resolution process will include, at a minimum, an attempt to resolve

disputes through communications between their staffs, and, if resolution is not reached at that level, a procedure for review and action on such disputes by appropriate management level officials within the AGENCY and the Contractor's organization.

In the event that a resolution of the dispute is not mutually agreed upon, the parties can agree to mediate the dispute or proceed with litigation. Notwithstanding any provision of this section, or any other provision of this Contract, it is expressly agreed and understood that any court proceeding arising out of a dispute under the Contract shall be heard by a Court de novo and the court shall not be limited in such proceeding to the issue of whether the Authority acted in an arbitrary, capricious or grossly erroneous manner.

Pending final settlement of any dispute, the parties shall proceed diligently with the performance of the Contract, and in accordance with the AGENCY's direction or decisions made thereof.

Performance during Dispute

Unless otherwise directed by AGENCY, Contractor shall continue performance under this Contract while matters in dispute are being resolved.

Claims for Damages

Should either party to the Contract suffer injury or damage to person or property because of any act or omission of the party or of any of its employees, agents or others for whose acts it is legally liable, a claim for damages therefor shall be made in writing to such other party within a reasonable time after the first observance of such injury or damage.

IT ACQUISITION REGULATION

CONTRACTOR certifies through the signing of this contract that, consistent with Section 889 of the John S. McCain National Defense Authorization Act for Fiscal Year 2019, Pub. L. 115-232 (Aug. 13, 2018), the CONTRACTOR does not and will not use any equipment, system, or service that uses "covered telecommunications equipment or services" (as that term is defined in Section 889 of the Act) as a substantial or essential component of any system or as critical technology as part of any system. The CONTRACTOR will include this certification as a flow down clause in any contract related to this Contract.

INCORPORATION OF FEDERAL TRANSIT ADMINISTRATION TERMS

Incorporation of Federal Transit Administration (FTA) Terms – The preceding provisions include, in part, certain Standard Terms and Conditions required by DOT whether or not expressly set forth in the preceding contract provisions. All contractual provisions required by DOT as set forth in FTA Circular 4220.1E are hereby incorporated by reference. Anything to the contrary herein notwithstanding, all FTA mandated terms shall be deemed to control in the event of a conflict with other provisions contained in this Agreement. The CONTRACTOR shall not perform any act, fail to perform any act, or refuse to comply with any RVTB requests which would cause RVTB to be in violation of the FTA terms and conditions.

Section 18: RVTD Campus Layout







ANGI
ENERGY SYSTEMS







BE
Automation

Power supply and control units including SOLA PS-250, SOLA PS-150, SOLA DC24BAT, and a relay assembly with a red "20 VOLTS" label.

Terminal block with numerous blue and red wires connected to it.

Terminal block with blue and red wires, and a small control module.

Main wiring area with multiple rows of terminal blocks, a central switch, and a power outlet.

Small metal enclosure or component box.

Magnum
Magnum

Black power supply unit or component box.

Bundle of blue, red, and white wires on the left side of the cabinet.

Bundle of blue and white wires on the right side of the cabinet.







EATON ON
Heavy Duty Safety Switch
Interrupción de energía a mayor velocidad
Interrupción de energía de acción pasada
600 A, 480 V_{L-L}, 60 Hz, 3000⁺

CAUTION
AVERTISSEMENT
PRECAUCIÓN

SIEMENS
ON
Heavy Duty Safety Switch
Interrupción de energía a mayor velocidad
Interrupción de energía de acción pasada
600 A, 480 V_{L-L}, 60 Hz, 3000⁺
OFF
DISCONNECT
60-480V 60-60Hz

SIEMENS
ON
Heavy Duty Safety Switch
Interrupción de energía a mayor velocidad
Interrupción de energía de acción pasada
600 A, 480 V_{L-L}, 60 Hz, 3000⁺
OFF
CONTROL TRANSFORMER
DISCONNECT
18 800V 0-100

277/480 VOLTS V1E
PROHIBIDO TO CONECT
PELIGRO

EMERGENCY SHUT-OFF



CONTROL POWER ON



OFF LOCK ON



COMPRESSOR 1

BOTH

COMPRESSOR 2

START



FAULT



STOP



RESET



RUNNING HOURS



START



FAULT



STOP



RESET



RUNNING HOURS



120 VOLTS

Section 20: Existing Fueling Station As-Builts

PLANS FOR RVTD CNG FUELING STATION FOR ADROIT CONSTRUCTION

OCTOBER 2011

NOTE:
ITEMS NOT ADDRESSED IN THE SPECIFICATIONS SPECIFIC TO THIS PROJECT SHALL BE GOVERNED BY THE CITY OF MEDFORD'S STANDARD SPECIFICATIONS. ITEMS NOT ADDRESSED IN THE CITY'S SPECIFICATIONS SHALL BE GOVERNED BY THE 2008 EDITION OF THE OREGON STANDARD SPECIFICATIONS FOR CONSTRUCTION.



PREPARED BY:
HUNT, GUILLOT & ASSOCIATES, L.L.C.
CONSULTING ENGINEERS AND PROJECT MANAGERS
P.O. BOX 580
RUSTON, LA 71273

APPROVED FOR
CONSTRUCTION
DATE: 10/12/11

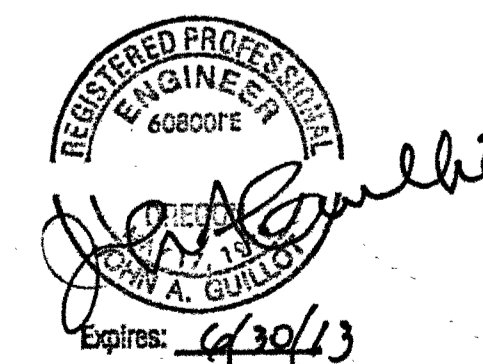

HUNT, GUILLOT & ASSOCIATES, L.L.C.
CONSULTING ENGINEERS AND PROJECT MANAGERS
P.O. BOX 580 RUSTON, LA 71273
MODEL NO.:

CONFIDENTIAL
THESE DESIGNS AND DRAWINGS ARE THE EXCLUSIVE PROPERTY OF:
HUNT, GUILLOT & ASSOCIATES, RUSTON, LA.
NO COPY OR REPRODUCTION MAY BE MADE WITHOUT WRITTEN APPROVAL.

**ADROIT CONSTRUCTION
RVTD CNG FUELING STATION
TITLE SHEET**

DESIGNED BY	PBW	8/23/11	CHECKED BY	CEH	9/14/11
DRAWN BY	PBW	8/23/11	APPROVED BY	RSO	9/14/11
PLOT AT 1:1		DATE: 8/23/11	HGA JOB NO: 7.110004 HGA ITEM NO:		
SCALE	DRAWING NUMBER		REV.		
1"=150'-0"	7.110004-T-001		0		

REV.	DESCRIPTION	CHK.	DATE	APP.	DATE
0	ISSUED FOR CONSTRUCTION	CEH	10/12/11	RSO	10/12/11
A	ISSUED FOR APPROVAL	CEH	9/14/11	RSO	9/14/11

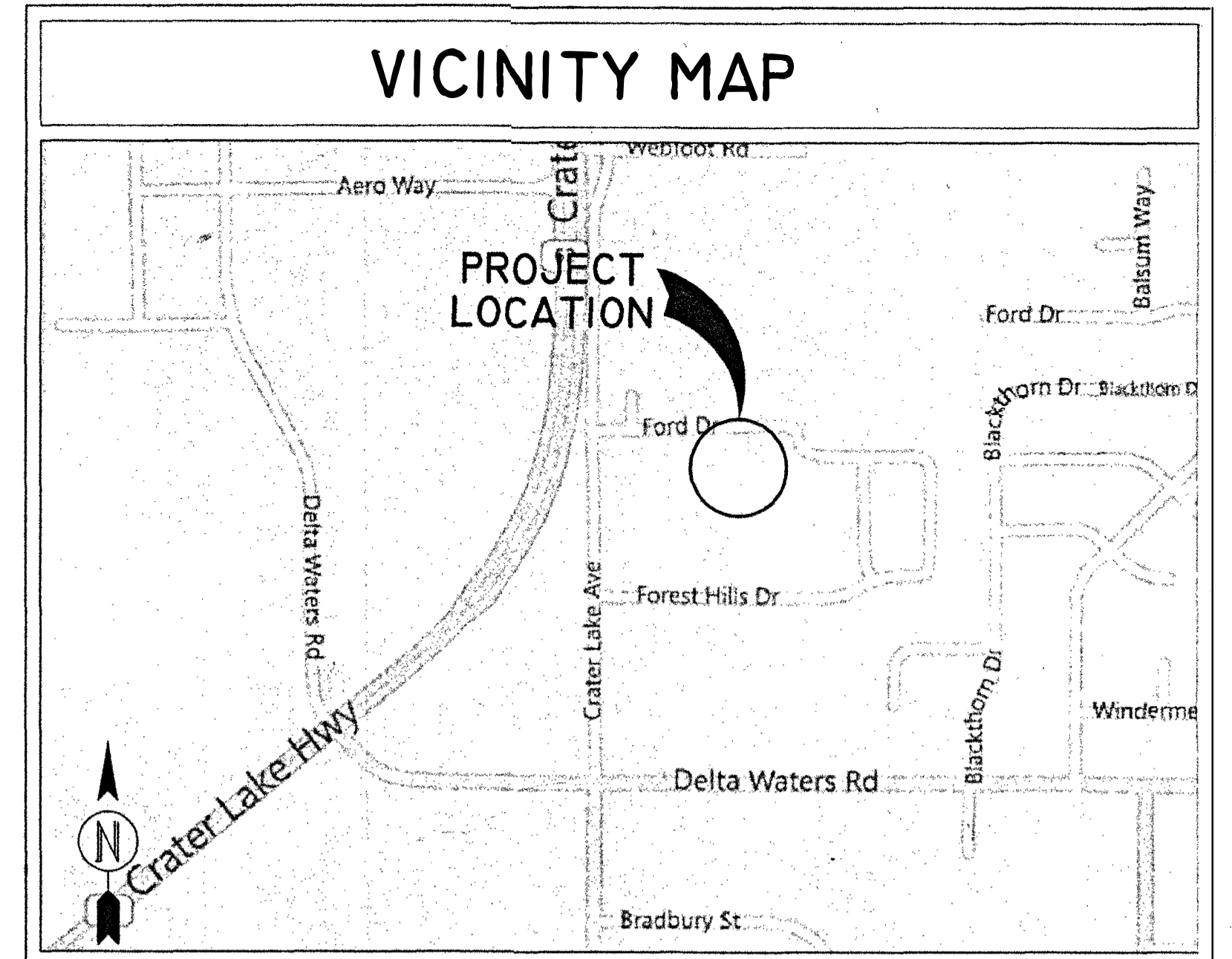

ROGUE VALLEY TRANSPORTATION DISTRICT APPROVAL

APPROVED BY _____ DATE _____

PRESIDENT _____

SHEET INDEX

SHEET NO.	DESCRIPTION
T-001	TITLE SHEET
C-001	TOPOGRAPHIC SURVEY
C-002	DEMOLITION PLAN
C-003	SITE LAYOUT PLAN
C-004	PAVING, GRADING & DRAINAGE PLAN
C-100	SECTIONS AND DETAILS SHEET 1
C-101	SECTIONS AND DETAILS SHEET 2
C-200	GENERAL NOTES
C-201	EROSION CONTROL DETAILS
C-202	FENCE DETAILS
M-001	SITE LAYOUT
M-002	EQUIPMENT LAYOUT
M-003	DISPENSER LAYOUT
M-004	PIPE SPECIFICATIONS
E-001	ONE-LINE/GENERAL NOTES
E-002	ELECTRICAL SITE PLAN
E-003	ELECTRICAL DETAILS
STD-F-001	ANCHOR BOLT DETAILS

RECORD DRAWINGS

TOPOGRAPHIC MAP OF SURVEY

Located in the Southwest One-quarter of Section 8, Township 37, Range 1 West of the Willamette Meridian, City of Medford, Jackson County, Oregon.

PREPARED FOR:
 ROGUE VALLEY TRANSPORTATION DISTRICT
 3200 Crater Lake Avenue
 Medford, OR 97504

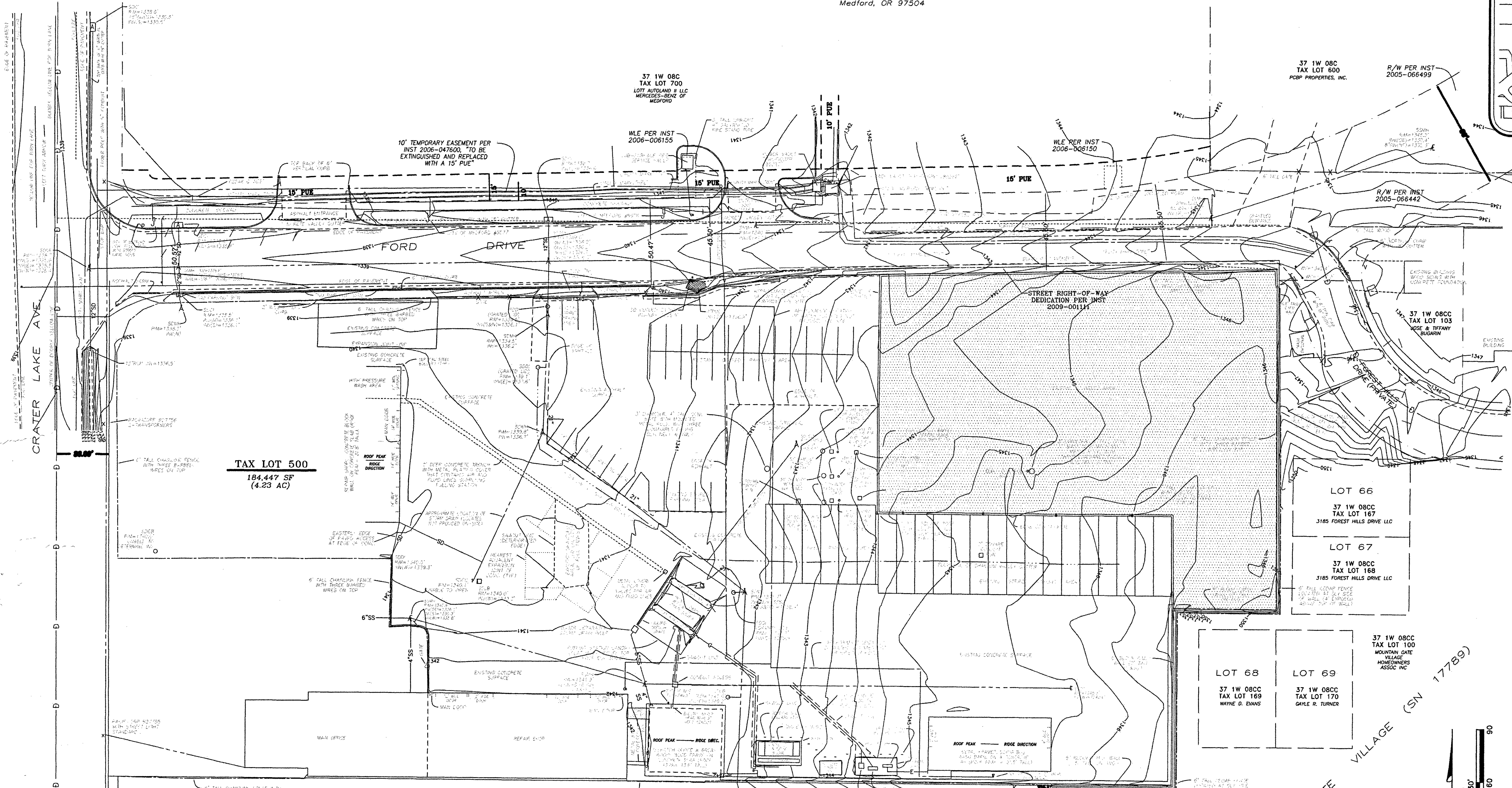
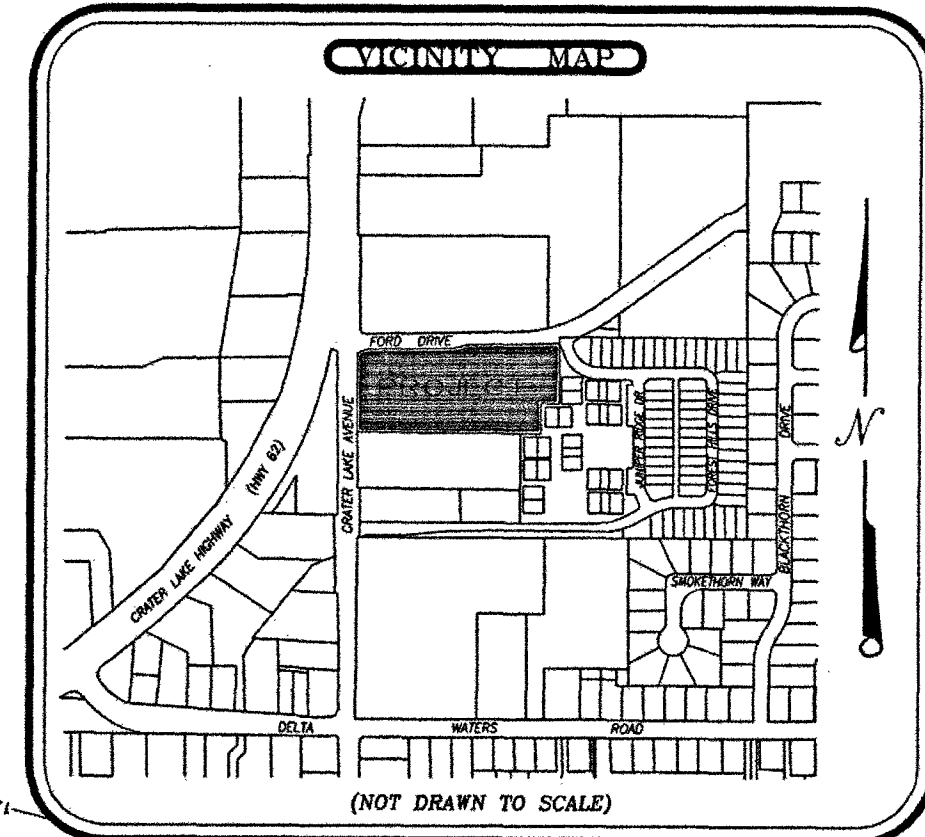

- LEGEND:**
- Indicates a utility marked gas line.
 - V Indicates an existing gas valve.
 - ⊕ Indicates an existing gas meter.
 - A Indicates an existing gas fiberglass sign/placard.
 - SS— Indicates a utility marked sanitary sewer line.
 - ⊕ Indicates an existing sanitary sewer manhole.
 - ⊕ Indicates an existing sanitary sewer cleanout.
 - S— Indicates an existing sanitary sewer lateral.
 - SD— Indicates a utility marked storm sewer line.
 - A Indicates an existing storm sewer manhole.
 - ⊕ Indicates an existing storm sewer cleanout.
 - ⊕ Indicates an existing mail box on a concrete slab.
 - J Indicates an existing street light.
 - ⊕ Indicates an existing power pedestal.
 - ⊕ Indicates an existing power meter box.
 - ⊕ Indicates an existing power pole and guy anchor.
 - OHU— Indicates an existing overhead utility line.
 - OHE— Indicates an existing overhead electric line.
 - E— Indicates a utility marked buried electric line.
 - T— Indicates a utility marked telephone line.
 - ⊕ Indicates an existing telephone pedestal.
 - W— Indicates a utility marked water line.
 - ⊕ Indicates an existing water meter.
 - ⊕ Indicates an existing water valve.
 - ⊕ Indicates an existing fire hydrant.
 - ⊕ Indicates an existing irrigation water spigot.
 - ⊕ Indicates an existing lawn irrigation box.
 - ⊕ Indicates a deciduous tree with drip-line diameter drawn to scale.
 - ⊕ Indicates a non-deciduous tree with drip-line diameter drawn to scale.
 - ww=1000' Indicates the elevation at the top of the valve nut for a water valve.
 - n, ne, nw Indicates a general direction: northerly, northeasterly, northwesterly, etcetera.
 - CLF Indicates a chain link fence.
 - WBF Indicates a wood board fence.
 - ep Indicates the edge of a paved street.
 - tbc Indicates the top back of a 6" vertical curb.
 - Indicates centerline of an existing fence line.

PROJECT NOTES:

Contour Interval: 0.5 foot
 Index Contour Interval: 1 foot

All existing underground utilities, as depicted hereon, were located with reasonable accuracy, as marked on the ground by affected agencies and utility companies. Oregon Administrative Rules Chapter 952, Division 1, Definitions, 95-001-0010 (12), states: "reasonable accuracy" means location within 24 inches of the outside lateral dimensions of both sides of an underground facility.

Property herein, in accordance with the public records report provided by AmeriTitle, may be subject to the following matters of record:

Regulations, including levies, assessments, water and irrigation rights and easements for ditches and canals of the Rogue River Valley Irrigation District.

The rights of the public in and to the subject tract of land hereof, lying within the limits of public roads, streets and highway.

The terms, provisions and conditions, including but not limited to maintenance provisions, dealing mainly with public sewer lines, per the Agreement Granting Easements in Instrument No. 75-07946 of the Official Records of Jackson County, Oregon; report notes as being appurtenant to subject tract.

The Terms and Provisions of a Mortgage recorded as Instrument No. 82-10870 and a Promissory Note per Instrument No. 83-03704 of the Official Records of Jackson County, Oregon.

Underground 10-foot wide easement granted to Pacific Power and Light Co. per Instrument No. 87-22543 and to PacifiCorp per Instrument No. 94-34638, both of the Official Records of Jackson County, Oregon. The location of said easement was not able to be accurately placed hereon, further research and coordination with PacifiCorp would be necessary to locate.

Appurtenant easement for sewer lines per Instrument No. 85-10144 of the Official Records of Jackson County, Oregon.

BASIS OF SURVEY:

Basis of Bearings: Geodetic North based on WGS 84 (World Geodetic System 1984), via GPS (Global Positioning System) observations. Basis applied to the West line of Section 8 and centerline of Crater Lake Avenue, as depicted hereon.

Basis of Elevations: City of Medford vertical datum referenced from City of Medford Bench Mark Number A-231, having a published elevation of 1326.224 feet, and being a found brass disk in the center of a headwall of a box culvert under Crater Lake Avenue, being approximately 18 feet southerly of power pole number PacifiCorp 080500 and approximately 250 feet northerly of the One-quarter Corner common to Sections 7 and 8, Township 37 South, Range 1 West of the Willamette Meridian, in the City of Medford, Jackson County, Oregon.

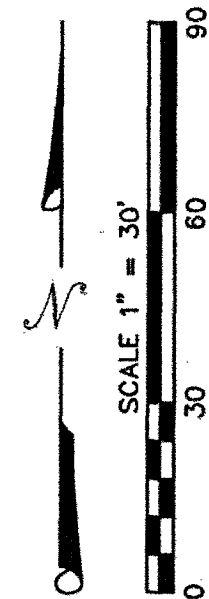

ABBREVIATIONS:

- CMP= Indicates an existing corrugated metal pipe.
- PVC= Indicates an existing polyethylene vinyl chlorid pipe.
- RCP= Indicates an existing re-enforced concrete pipe.
- SSCO= Indicates an existing sanitary sewer cleanout.
- SSMH= Indicates an existing sanitary sewer manhole.
- SDCO= Indicates an existing storm sewer cleanout.
- SDCI= Indicates an existing storm sewer curb inlet.
- WV= Indicates an existing water valve.

PREPARED BY: **Neathamer Surveying, Inc.**
 3132 St, Suite 110
 P.O. Box 1584
 Medford, Oregon 97501
 Phone (541) 732-2869
 FAX (541) 732-1382

PLOT DATE: May 6, 2009 PROJECT NUMBER: 09020

Sheet 1 of 1 ©

THIS SURVEY DRAWING WAS PROVIDED TO HUNT, GUILLOT, AND ASSOCIATES BY ROGUE VALLEY TRANSPORTATION DISTRICT. IT IS PROVIDED FOR REFERENCE SINCE IT WAS THE BASIS OF HUNT, GUILLOT, AND ASSOCIATES DESIGN.

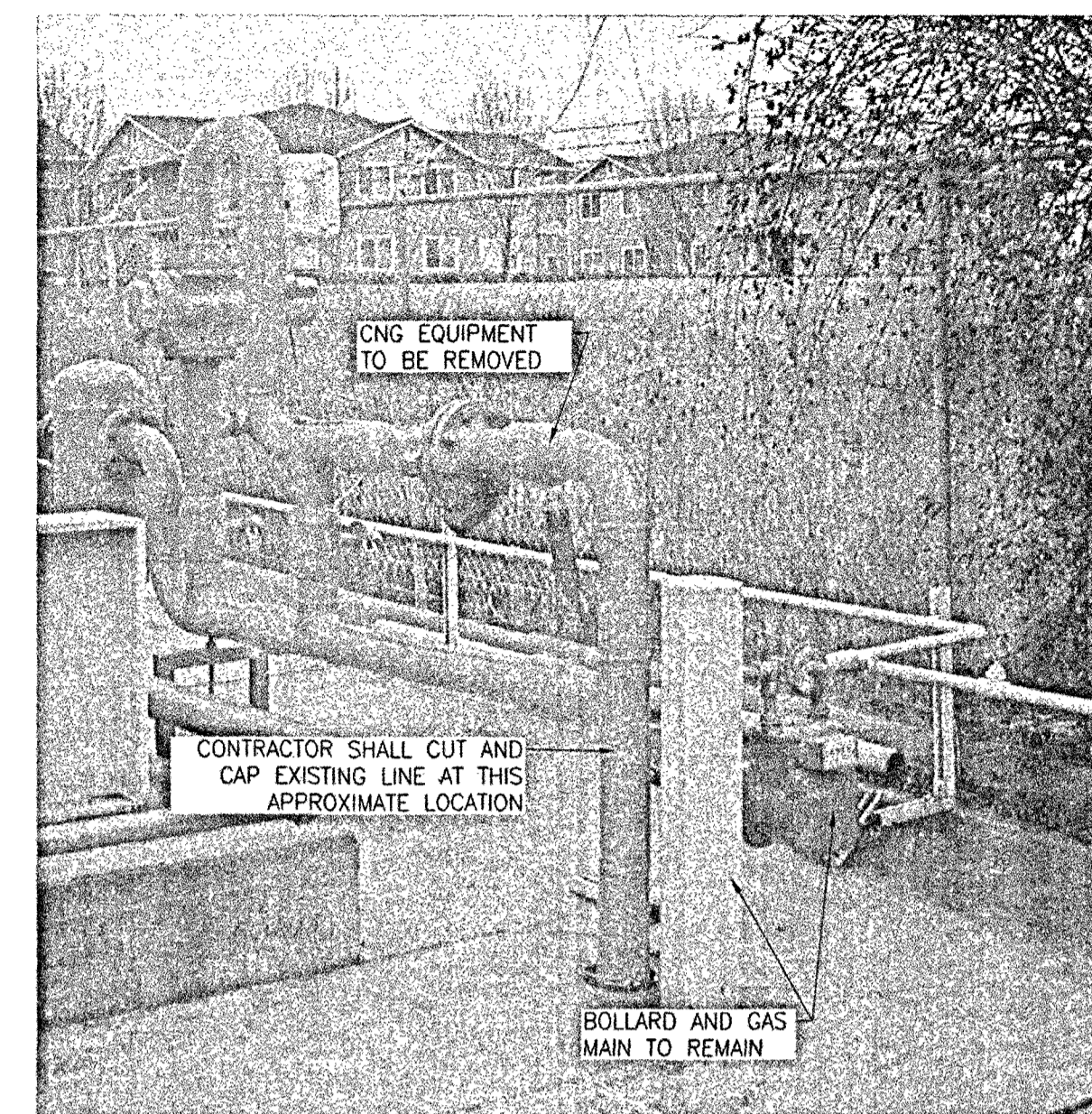
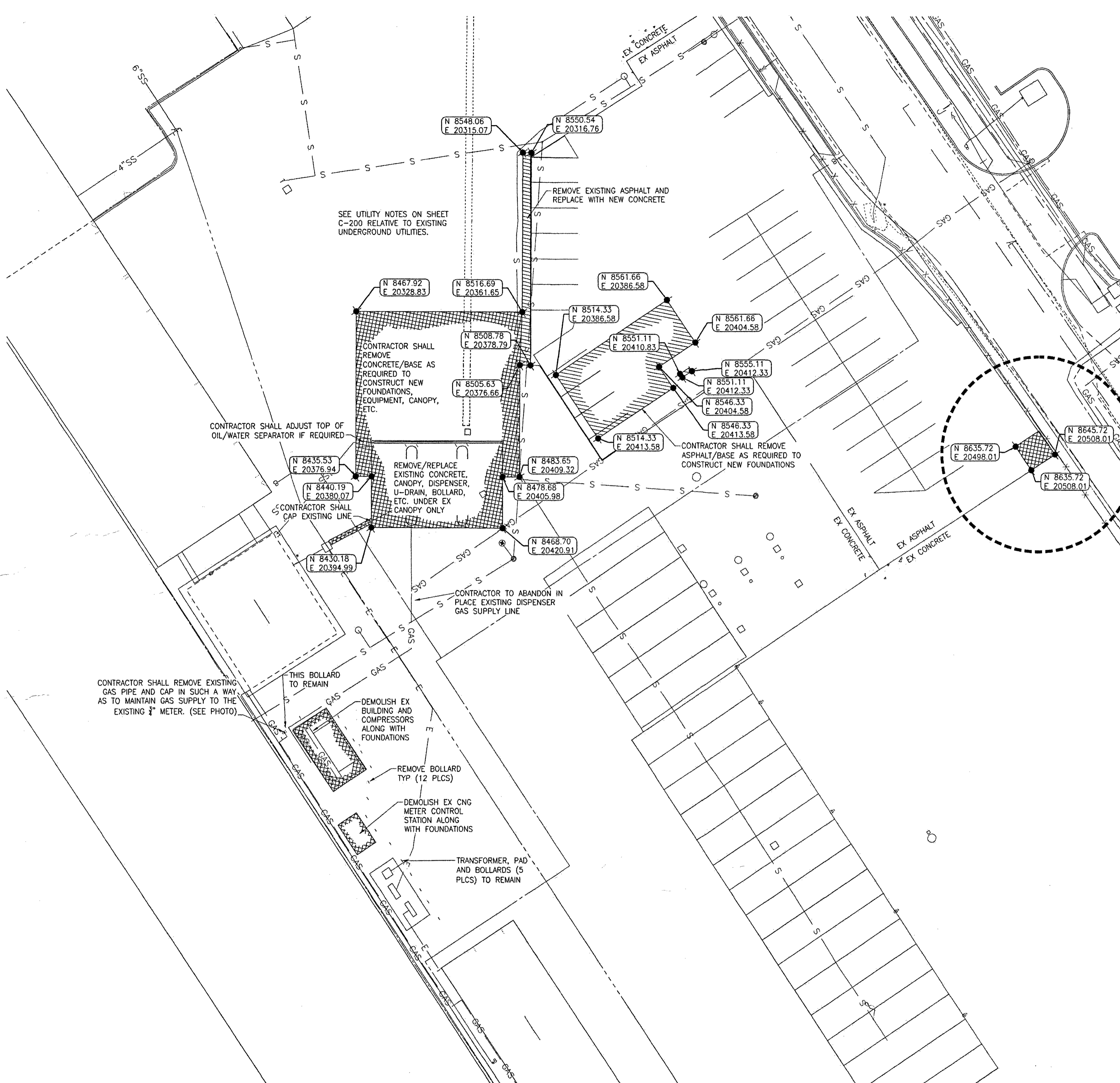

EXISTING GAS LINE & METER

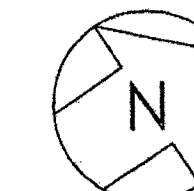

LEGEND	
	FIRE HYDRANT
	POWER POLE
	LIGHT POLE
	GUY WIRE
	ELECTRIC LINE
	PROPERTY LINE
	FIBER OPTIC CABLE
	GAS LINE
	WATER LINE
	RIGHT OF WAY
	TELEPHONE PEDESTAL
	EXISTING FENCE
	CONCRETE PAVING
	LANDSCAPING
	DEMOLITION CONCRETE AREA
	DEMOLITION ASPHALT AREA

NOTES:

- CONTRACTOR SHALL BE RESPONSIBLE FOR THE DISPOSAL OF ALL DEMOLISHED MATERIAL AT AN OFF-SITE LOCATION.
- CONTRACTOR SHALL DEMOLISH AS NEEDED TO INSTALL FOUNDATIONS.
- CONTRACTOR SHALL REMOVE SURFACE AND SUBSURFACE AS NECESSARY TO ROUTE CONDUITS IN ACCORDANCE WITH MECHANICAL AND ELECTRICAL DRAWINGS. ALL TRENCHES SHALL BE BACKFILLED AND RETURNED TO EXISTING CONDITIONS UNLESS OTHERWISE NOTED.
- CONTRACTOR SHALL BE RESPONSIBLE FOR THE REMOVAL/DEMOLITION OF EXISTING PIPE WITHIN THE DEMOLITION LIMITS IN STRICT COMPLIANCE WITH ALL FEDERAL, STATE, AND LOCAL REGULATIONS.
- ALL EDGE OF DEMOLITION AREAS SHALL BE SAWCUT ONE-HALF THE DEPTH OF THE PAVEMENT BUT NOT LESS THAN FOUR (4) INCHES TO PROVIDE A CLEAN EDGE.
- NO SOIL REPORT OR AS BUILT INFORMATION WERE PROVIDED FOR THIS SITE. CONTRACTOR SHALL DETERMINE EXISTING PAVEMENT THICKNESS.

REFERENCE DRAWINGS

- 7.110004-C-003 ADROIT CONSTRUCTION RVTD CNG FUELING STATION SITE LAYOUT PLAN
- 7.110004-C-200 ADROIT CONSTRUCTION RVTD CNG FUELING STATION GENERAL NOTES

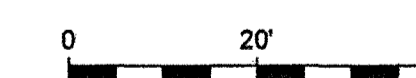

APPROVED FOR CONSTRUCTION
DATE: 10/12/11

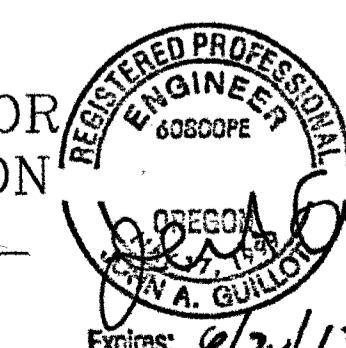

HUNT, GUILLOT & ASSOCIATES, L.L.C.
CONSULTING ENGINEERS AND PROJECT MANAGERS
P.O. BOX 580 RUSTON, LA 71273

CONFIDENTIAL
THESE DESIGNS AND DRAWINGS ARE THE EXCLUSIVE PROPERTY OF:
HUNT, GUILLOT & ASSOCIATES, RUSTON, LA.
NO COPY OR REPRODUCTION MAY BE MADE WITHOUT WRITTEN APPROVAL.

**ADROIT CONSTRUCTION
RVTD CNG FUELING STATION
DEMOLITION PLAN**

DESIGNED BY	PBW	8/11/11	CHECKED BY	CEH	9/14/11
DRAWN BY	PBW	8/11/11	APPROVED BY	RSO	9/14/11
PLOT AT 1:1	DATE: 8/23/11	HGA JOB NO: 7110004	HGA ITEM NO:		
SCALE	DRAWING NUMBER	REV.			
1"=20'-0"	7.110004-C-002	0			

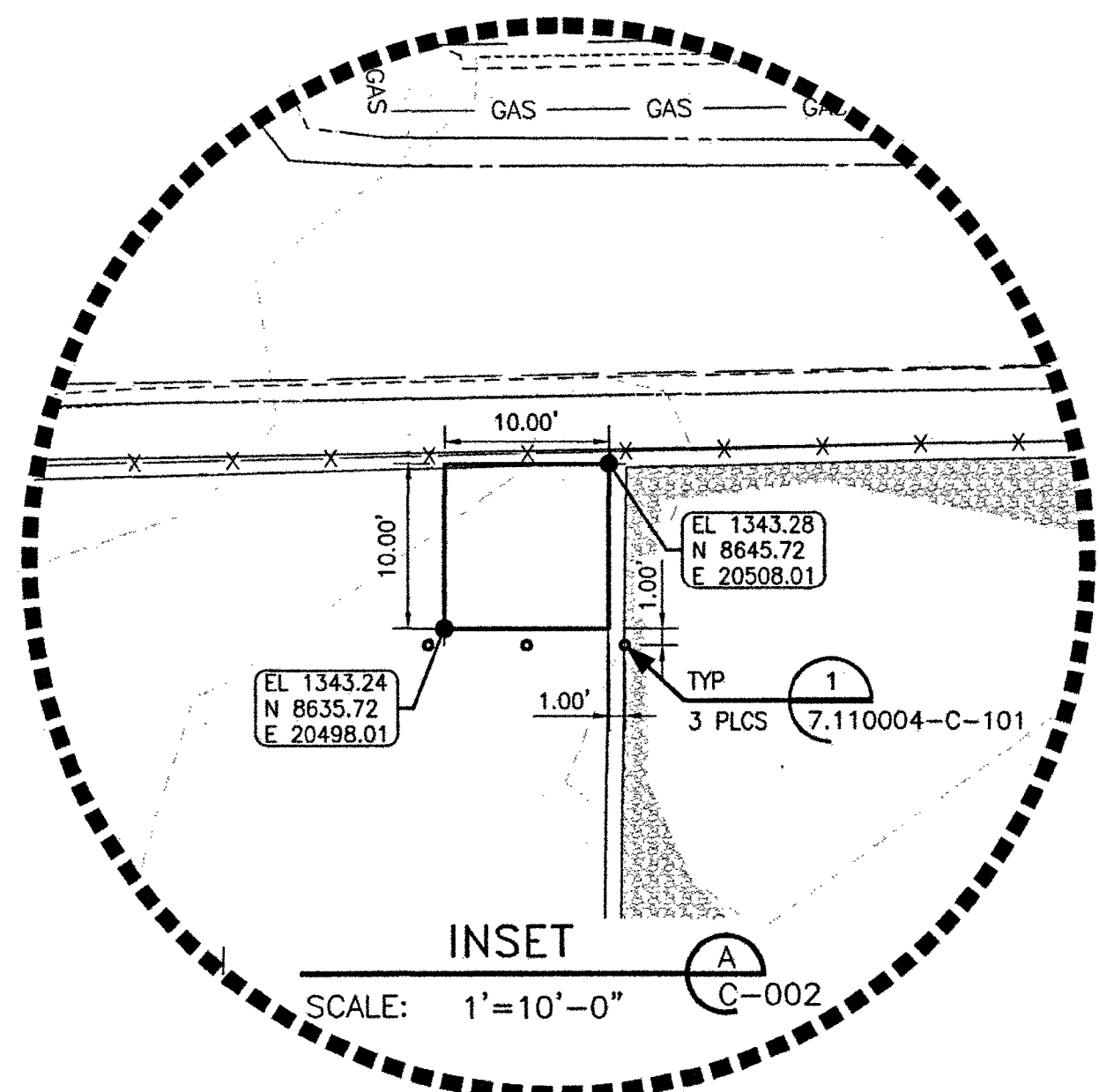
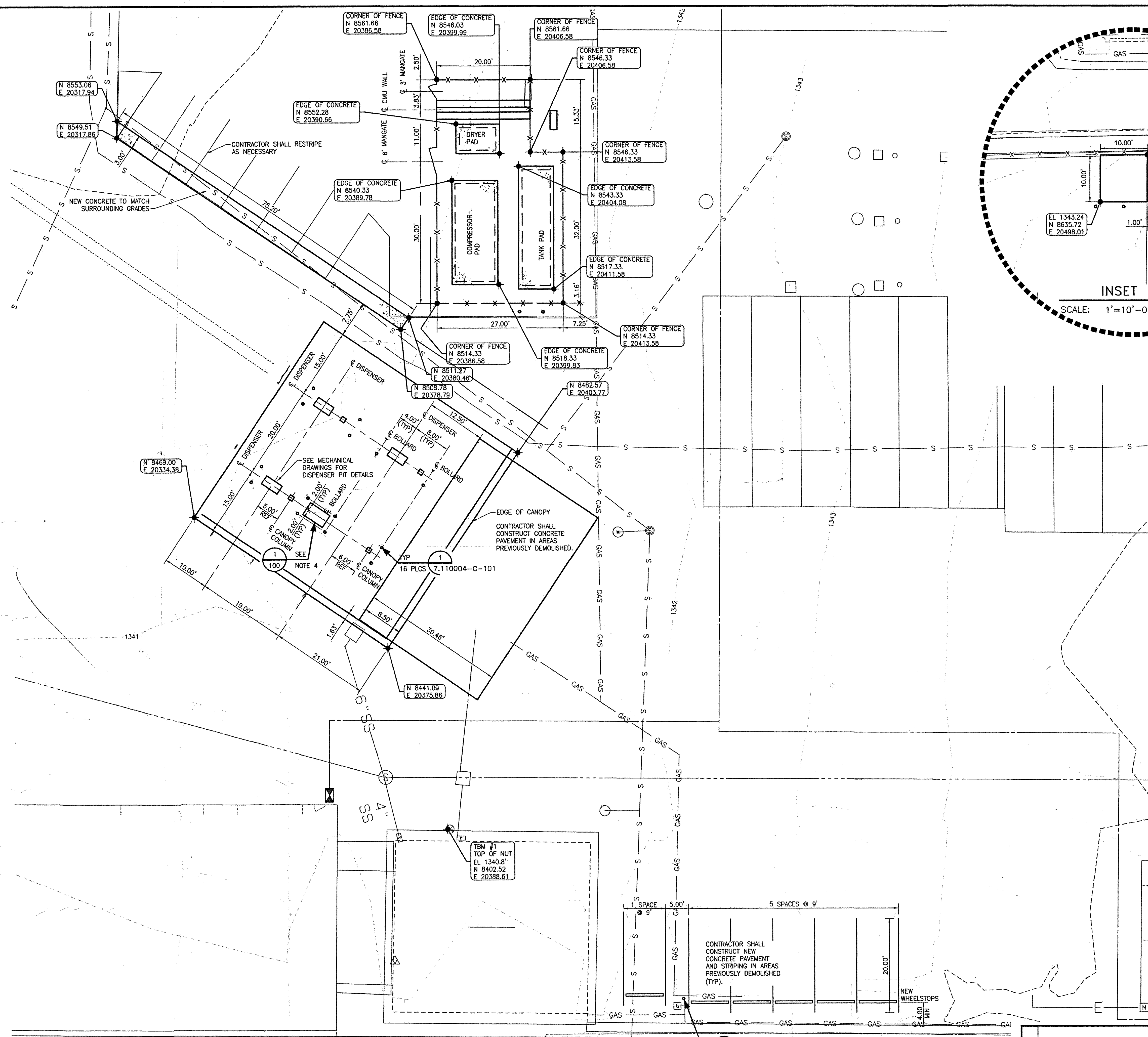

LEGEND	
	FIRE HYDRANT
	POWER POLE
	LIGHT POLE
	GUY WIRE
	ELECTRIC LINE
	PROPERTY LINE
	FIBER OPTIC CABLE
	GAS LINE
	WATER LINE
	RIGHT OF WAY
	TELEPHONE PEDESTAL
	EXISTING FENCE
	CONCRETE PAVING
	LANDSCAPING
	CONTOURS

- NOTES:**
- CONTRACTOR SHALL TRENCH AS REQUIRED TO ROUTE MECHANICAL AND ELECTRICAL LINES. TRENCHES SHALL BE FILLED IN ACCORDANCE WITH THE STANDARD PIPE/CONDUIT BEDDING DETAILS ON 7.110004-C-101.
 - CONTRACTOR SHALL INSTALL CANOPY FOUNDATIONS AS PER CANOPY MANUFACTURER DRAWINGS AND/OR RECOMMENDATIONS.
 - CONTRACTOR SHALL INSTALL TRANSFORMER VAULT AS PER VAULT MANUFACTURER DRAWINGS AND/OR RECOMMENDATIONS. VAULT SHALL HAVE A REMOVABLE LID.
 - CONTROL CABINET SHALL BE FIELD LOCATED TO BE CENTERED BETWEEN THE BOLLARDS AND ON THE CENTERLINE OF THE DISPENSERS.

- REFERENCE DRAWINGS**
- 7.110004-C-004 ADROIT CONSTRUCTION Rvtd CNG FUELING STATION PAVING, GRADING & DRAINAGE PLAN
 - 7.110004-C-200 ADROIT CONSTRUCTION Rvtd CNG FUELING STATION GENERAL NOTES

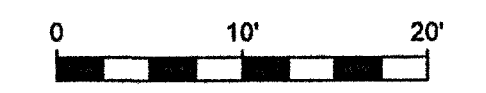

APPROVED FOR CONSTRUCTION
DATE: 10/12/11

HUNT, GUILLOT & ASSOCIATES, L.L.C.
CONSULTING ENGINEERS AND PROJECT MANAGERS
P.O. BOX 580 RUSTON, LA 71273

CONFIDENTIAL
THESE DESIGNS AND DRAWINGS ARE THE EXCLUSIVE PROPERTY OF:
HUNT, GUILLOT & ASSOCIATES, RUSTON, LA.
NO COPY OR REPRODUCTION MAY BE MADE WITHOUT WRITTEN APPROVAL.

ADROIT CONSTRUCTION
Rvtd CNG FUELING STATION
SITE LAYOUT PLAN

REV.	DESCRIPTION	CHK.	DATE	APP.	DATE
0	ISSUED FOR CONSTRUCTION	CEH	10/12/11	RSO	10/12/11
A	ISSUED FOR APPROVAL	CEH	9/14/11	RSO	9/14/11

DESIGNED BY	PBW	8/11/11	CHECKED BY	CEH	9/14/11
DRAWN BY	PBW	8/11/11	APPROVED BY	RSO	9/14/11
PLOT AT 1:1		DATE: 8/23/11	HGA JOB NO: 7110004 HGA ITEM NO:		
SCALE		DRAWING NUMBER		REV.	
1"=10'-0"		7.110004-C-003		0	

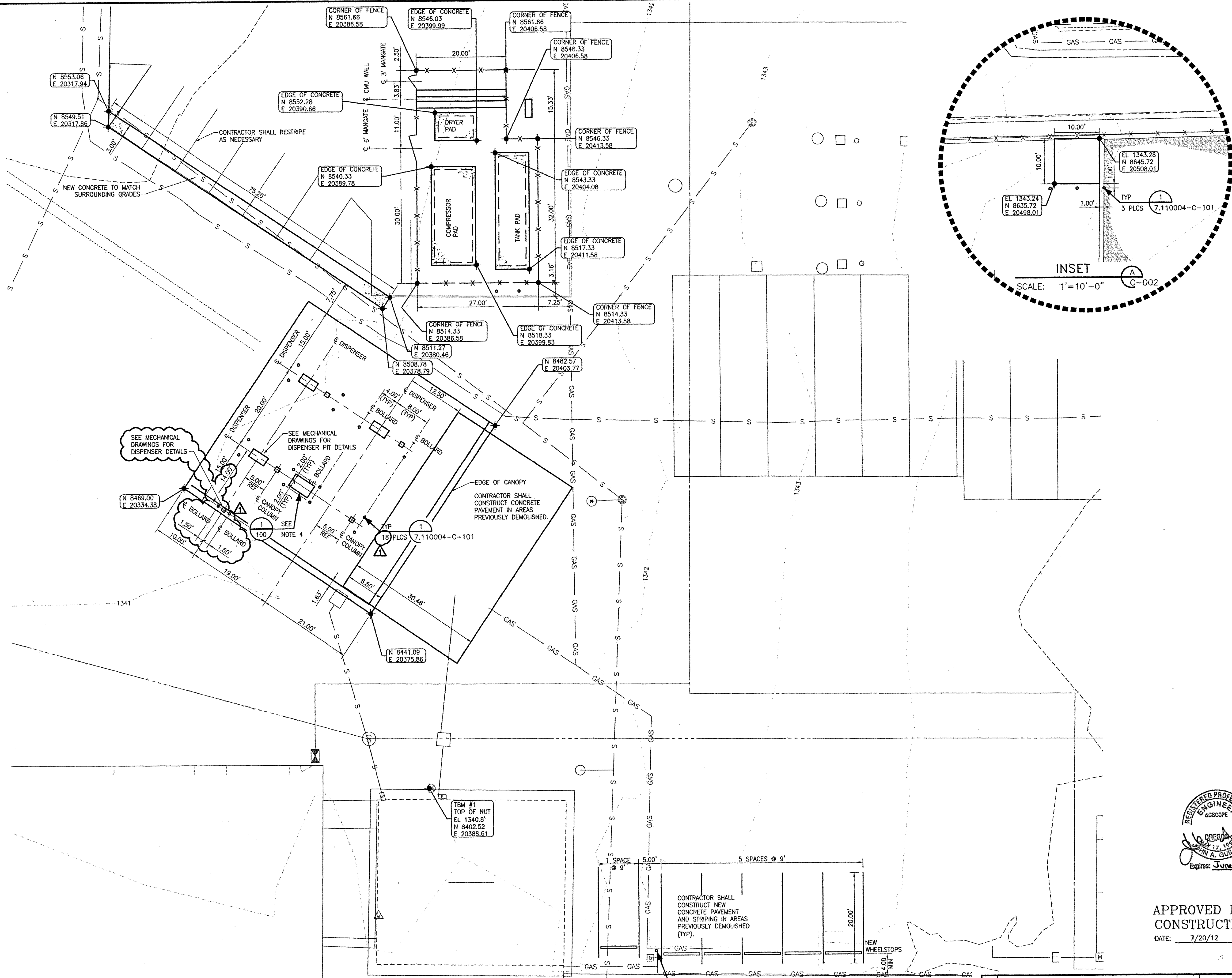

LEGEND	
	FIRE HYDRANT
	POWER POLE
	LIGHT POLE
	GUY WIRE
	ELECTRIC LINE
	PROPERTY LINE
	FIBER OPTIC CABLE
	GAS LINE
	WATER LINE
	RIGHT OF WAY
	TELEPHONE PEDESTAL
	EXISTING FENCE
	CONCRETE PAVING
	LANDSCAPING
	CONTOURS

- NOTES:**
- CONTRACTOR SHALL TRENCH AS REQUIRED TO ROUTE MECHANICAL AND ELECTRICAL LINES. TRENCHES SHALL BE FILLED IN ACCORDANCE WITH THE STANDARD PIPE/CONDUIT BEDDING DETAILS ON 7.110004-C-101.
 - CONTRACTOR SHALL INSTALL CANOPY FOUNDATIONS AS PER CANOPY MANUFACTURER DRAWINGS AND/OR RECOMMENDATIONS.
 - CONTRACTOR SHALL INSTALL TRANSFORMER VAULT AS PER VAULT MANUFACTURER DRAWINGS AND/OR RECOMMENDATIONS. VAULT SHALL HAVE A REMOVABLE LID.
 - CONTROL CABINET SHALL BE FIELD LOCATED TO BE CENTERED BETWEEN THE BOLLARDS AND ON THE CENTERLINE OF THE DISPENSERS.

- REFERENCE DRAWINGS**
- 7.110004-C-004 ADROIT CONSTRUCTION RVTD CNG FUELING STATION PAVING, GRADING & DRAINAGE PLAN
 - 7.110004-C-200 ADROIT CONSTRUCTION RVTD CNG FUELING STATION GENERAL NOTES

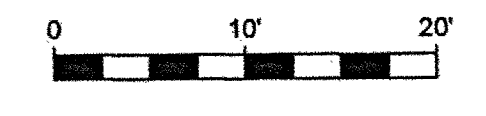

REGISTERED PROFESSIONAL ENGINEER
 HUNT, GUILLOT & ASSOCIATES, L.L.C.
 APR 17, 2012
 JOHN A. GUILLOT
 Expires: June 30, 2013

APPROVED FOR CONSTRUCTION
 DATE: 7/20/12

HUNT, GUILLOT & ASSOCIATES, L.L.C.
 CONSULTING ENGINEERS AND PROJECT MANAGERS
 P.O. BOX 580 RUSTON, LA 71273

CONFIDENTIAL
 THESE DESIGNS AND DRAWINGS ARE THE EXCLUSIVE PROPERTY OF:
 HUNT, GUILLOT & ASSOCIATES, RUSTON, LA.
 NO COPY OR REPRODUCTION MAY BE MADE WITHOUT WRITTEN APPROVAL.
ADROIT CONSTRUCTION
RVTD CNG FUELING STATION
SITE LAYOUT PLAN

REV.	DESCRIPTION	CHK.	DATE	APP.	DATE
1	ADDED DISPENSER AND BOLLARDS	CEH	7/20/12	RSO	7/20/12
0	ISSUED FOR CONSTRUCTION	CEH	10/12/11	RSO	10/12/11
A	ISSUED FOR APPROVAL	CEH	9/14/11	RSO	9/14/11

DESIGNED BY	PBW	8/11/11	CHECKED BY	CEH	9/14/11
DRAWN BY	PBW	8/11/11	APPROVED BY	RSO	9/14/11
PLOT AT 1:1		DATE: 8/23/11	HGA JOB NO: 7110004 HGA ITEM NO:		
SCALE		DRAWING NUMBER		REV.	
1"=10'-0"		7.110004-C-003		1	

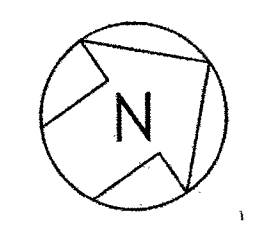

LEGEND	
	FIRE HYDRANT
	POWER POLE
	LIGHT POLE
	GUY WIRE
	ELECTRIC LINE
	PROPERTY LINE
	FIBER OPTIC CABLE
	GAS LINE
	WATER LINE
	RIGHT OF WAY
	TELEPHONE PEDESTAL
	EXISTING FENCE
	CONCRETE PAVING
	ASPHALT PAVING
	LANDSCAPING
	FLOW DIRECTION ARROW
	EXPANSION JOINT
	DUMMY JOINT
	THICKENED EDGE

NOTES:

- CONTRACTOR SHALL INSTALL CANOPY FOUNDATION IN ACCORDANCE WITH CANOPY VENDOR INSTRUCTIONS AND/OR DRAWINGS.
- CANOPY DOWNSPOUT SHALL BE FIELD ROUTED TO CONNECT TO STORM SYSTEM.
- FOUNDATION DESIGN IS BASED ON ASSUMED MINIMUM SOIL BEARING CAPACITIES AS PROVIDED BY THE CITY OF MEDFORD BUILDING SAFETY DEPARTMENT'S INFORMATION HANDOUT. IF THE SOIL BEARING PRESSURE IS FOUND TO BE LESS THAN THE ASSUMED MINIMUM, CONTRACTOR SHALL NOTIFY THE ENGINEER IMMEDIATELY.
- U-DRAIN CONSTRUCTION DRAWINGS SHALL BE SUBMITTED FOR APPROVAL PRIOR TO INSTALLATION. U-DRAIN SHALL BE INSTALLED ACCORDING TO MANUFACTURER'S RECOMMENDATIONS IN SUCH A WAY AS TO SECURE TO SURROUNDING PAVEMENT. U-DRAIN SHALL ALSO BE TRAFFIC RATED FOR CITY BUSES AND ADA COMPLIANT.
- PER CITY OF MEDFORD RECORDS, DETENTION FOR THIS SITE EXISTS. DRAINAGE FOR THIS AREA FLOWS INTO STORM DRAIN AND EXITS THROUGH A 21" DIAMETER STORM DRAIN TO THE WEST. THIS OUTFLOW HAS A DETENTION OUTFALL SYSTEM. PER STORM WATER CRORMANCE, STORM WATER QUALITY SHALL BE REQUIRED FOR THE ADDITIONAL CANOPY AND DISTURBED AREAS.
- THIS PROJECT REQUIRES 2817 SQUARE FEET OF DRAINAGE TO BE FILTERED. SEE PLAN FOR PROPOSED DRAINAGE AREA TO BE FILTERED.
- CONTRACTOR SHALL FIELD GRADE ALL CONCRETE AS NECESSARY TO DRAIN.

REFERENCE DRAWINGS

- 7.110004-C-003 ADROIT CONSTRUCTION R/VD CNG FUELING STATION SITE LAYOUT PLAN
- 7.110004-C-200 ADROIT CONSTRUCTION R/VD CNG FUELING STATION GENERAL NOTES

DETENTION AREA CALCULATIONS	
LOCATION	AREA (SQ. FT.)
EXISTING CANOPY	1413
PROPOSED CANOPY	2500
COMPRESSOR PAD	217
TANK PAD	197
DRYER PAD	60
CMU WALL	80
GAS METER	6
TRANSFORMER VAULT	100
EXISTING CNG EQUIPMENT PAD	366
EXISTING CNG METER CONTROL PAD	98
CONCRETE EXTENSION	225
TRENCHING	381
TOTAL	2817

APPROVED FOR CONSTRUCTION
DATE: 10/12/11

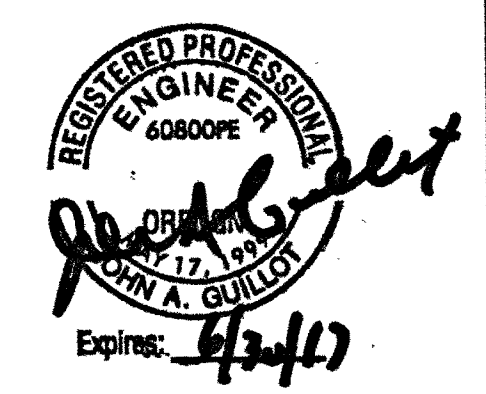
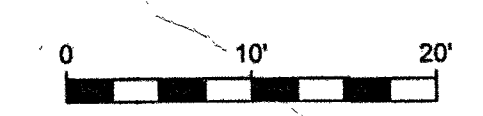

HUNT, GUILLOT & ASSOCIATES, L.L.C.
CONSULTING ENGINEERS AND PROJECT MANAGERS
P.O. BOX 580 RUSTON, LA 71273
MODEL #:

THESE DESIGNS AND DRAWINGS ARE THE EXCLUSIVE PROPERTY OF HUNT, GUILLOT & ASSOCIATES, RUSTON, LA. NO COPY OR REPRODUCTION MAY BE MADE WITHOUT WRITTEN APPROVAL.

ADROIT CONSTRUCTION R/VD CNG FUELING STATION PAVING, GRADING & DRAINAGE PLAN

REV.	DESCRIPTION	CHK.	DATE	APP.	DATE	SCALE	DRAWING NUMBER	REV.
0	ISSUED FOR CONSTRUCTION	CEH	10/12/11	RSO	10/12/11	1"=10'-0"	7.110004-C-004	0
A	ISSUED FOR APPROVAL	CEH	9/14/11	RSO	9/14/11			

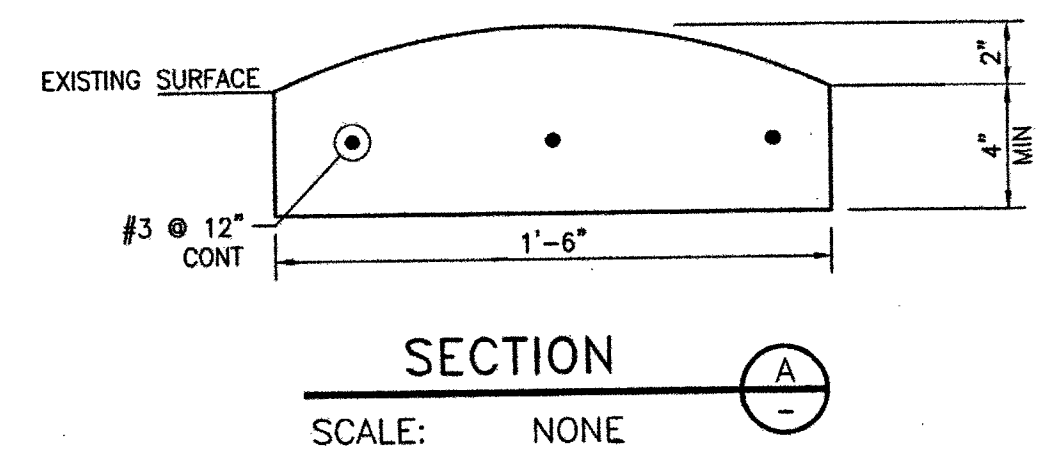

TANK 7'-6" x 25'-9"
Comp 9'-10" x 22'-0"
DRYER 6'-4" x 9'-4"

0.52 x 0.17
0.16
0.16

U-DRAIN
INV EL 1340.40

EL 1340.80
N 8510.48
E 20362.29

A 2" TALL BY 18" WIDE RAISED CONCRETE SECTION SHALL BE INSTALLED ON THE GROUND UNDER THE WEST AND SOUTH EDGE OF CANOPY. SEE DETAIL A

45 LF OF 6" PVC CONNECT TO EX INFLOW PIPE OF OIL/WATER SEPARATOR

CONTRACTOR SHALL VERIFY INVERT EL AND DRAINAGE SLOPE PRIOR TO INSTALLATION

SEE NOTE 2 FOR CANOPY DRAINAGE

OIL WATER SEPARATOR

EDGE OF CANOPY

AREA OF EXISTING CANOPY TO BE REPLACED

SEE INSTALL FLOWGUARD PLUS FILTER ON EXISTING INLET (SEE NOTE #6) (THIS INLET DRAINS 20943 SQ FT)

TBM #1
TOP OF NUT
EL 1340.8'
N 8402.52
E 20388.61

EL 1341.50
N 8518.33
E 20399.83

EL 1340.85
N 8508.78
E 20378.79

EL 1341.50
N 8540.33
E 20389.78

EL 1340.86
N 8511.27
E 20380.46

EL 1341.75
N 8543.33
E 20404.08

EL 1341.75
N 8517.33
E 20411.58

EL 1342.50
N 8645.72
E 20498.01

EL 1342.50
N 8635.72
E 20508.01

EL 1342.50
N 8645.72
E 20508.01

EL 1342.50
N 8645.72
E 20508.01

1342

1343

1342

1343

1342

1343

1342

1343

1342

1343

1342

1343

1342

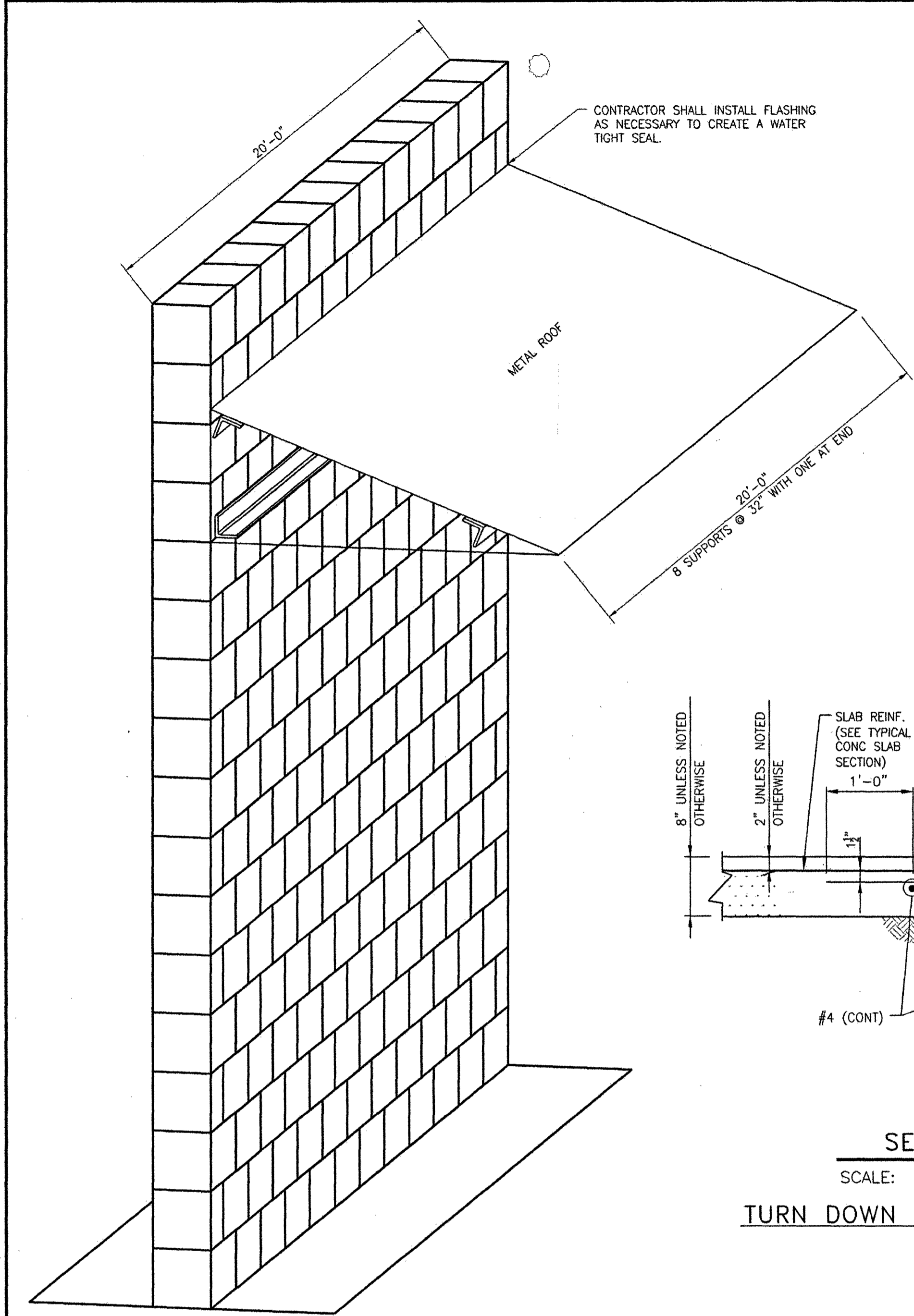

ISOMETRIC VIEW OF CMU WALL
SEE SECTION "B" THIS SHEET FOR FURTHER DETAILS

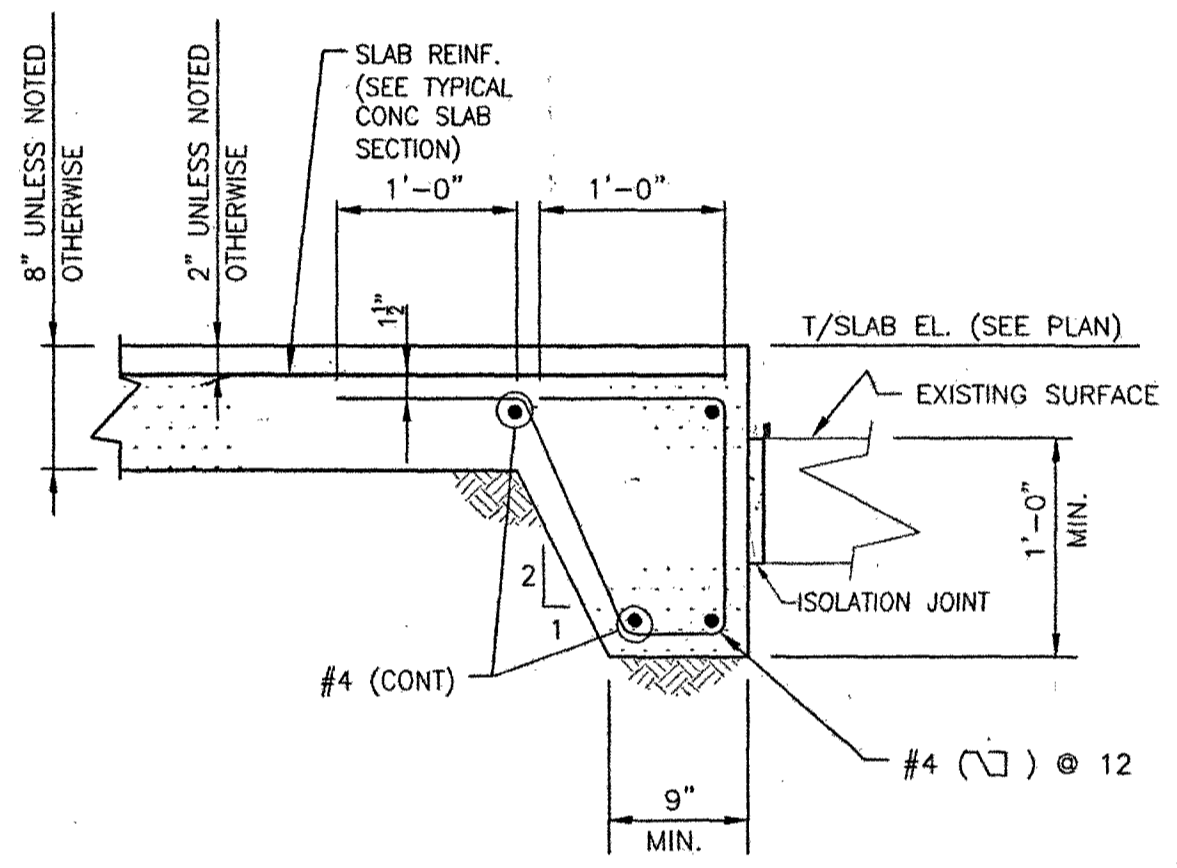

SECTION A
SCALE: 1"=1'-0"
TURN DOWN SLAB WITHOUT CURB

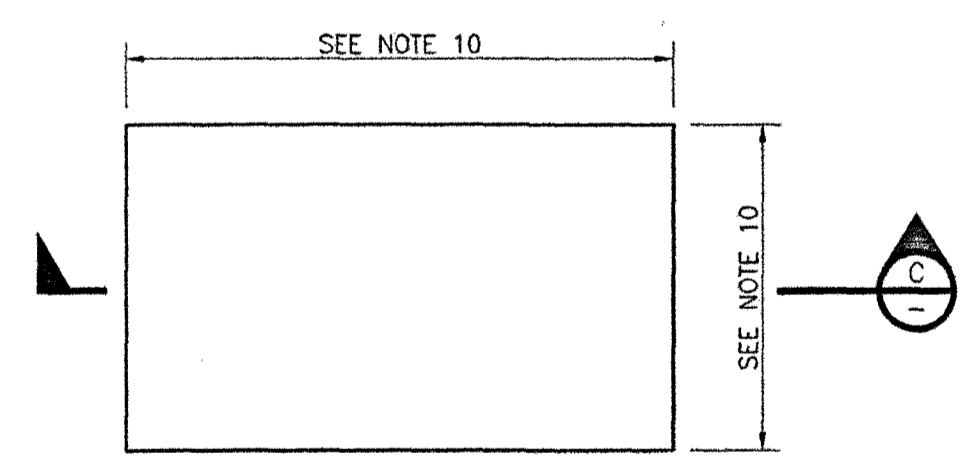

DETAIL 1
SCALE: NONE

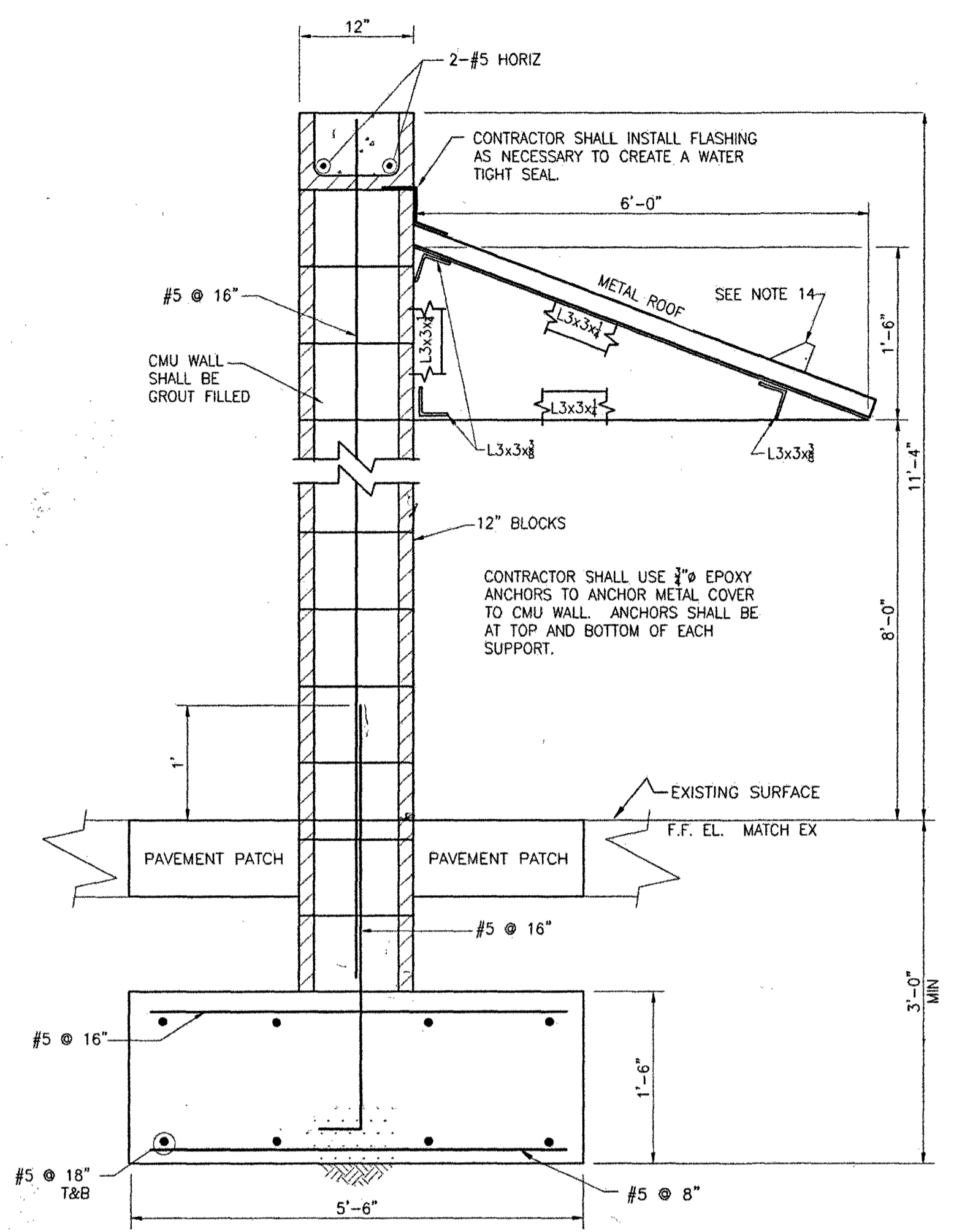

SECTION B
SCALE: 1"=1'-0"

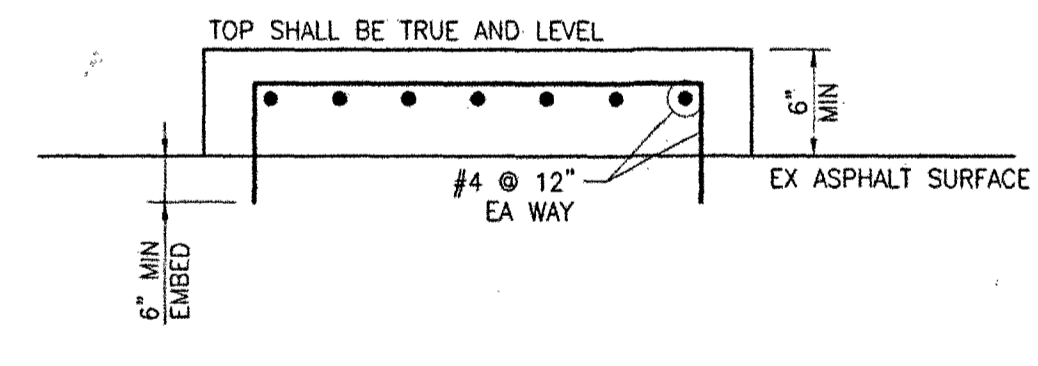

SECTION C
SCALE: NONE

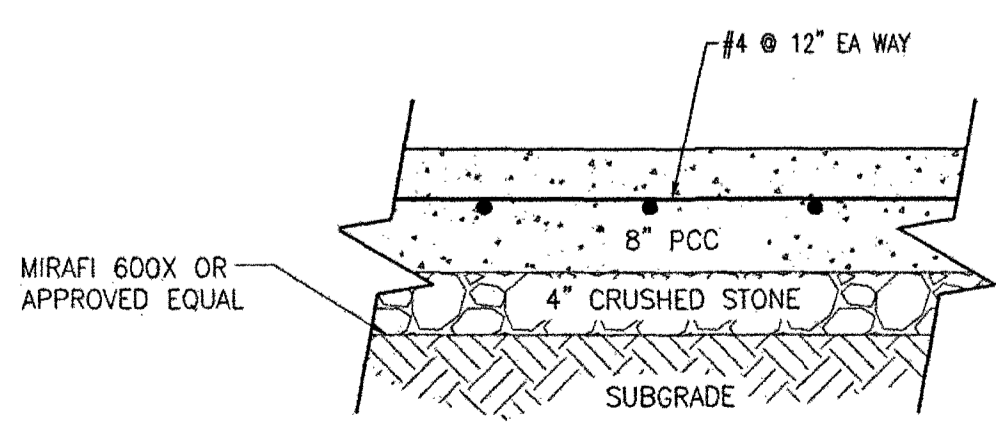

TYPICAL CONCRETE SLAB SECTION

GENERAL NOTES

- OVERALL DIMENSIONS OF ALL PADS ARE APPROXIMATE. CONTRACTOR SHALL VERIFY THAT ALL ANCHOR BOLTS SHALL BE 6" OR GREATER FROM THE NEAREST EDGE OF CONCRETE AND ADJUST PAD SIZE APPROPRIATELY.
- CONTRACTOR SHALL ANCHOR ALL EQUIPMENT.
- CONTRACTOR SHALL INSTALL ALL HOLES AND/OR PROTRUSIONS OF CONCRETE IN ACCORDANCE WITH DETAILS 2 & 3 LOCATED ON SHEET 7.110004-C-101.
- ALL NECESSARY EQUIPMENT SHALL BE ANCHORED IN ACCORDANCE WITH DETAIL 4 LOCATED ON SHEET 7.110004-C-101.
- ALL CONCRETE SHALL HAVE A COMPRESSIVE STRENGTH OF 4000 PSI.
- ALL STEEL SHALL BE 60 KSI.
- PRIOR TO ADDING ANY NEW MATERIAL THE EXISTING SOIL MUST BE COMPACTED TO 95% STANDARD PROCTOR TEST (ASTM D698). ANY SOFT AREAS FOUND SHALL BE REPLACED WITH SELECT BACKFILL.
- GEOTEXTILE FABRIC (WOVEN) SHALL BE USED UNDER ALL CRUSHED STONE.
- ALL CRUSHED STONE SHALL BE COMPACTED TO 98% OF LABORATORY MAXIMUM AS DETERMINED BY ASTM D698 METHOD C.
- CONTRACTOR SHALL SIZE PAD TO HAVE NINE (9") INCHES OF HORIZONTAL CLEARANCE ON ALL ANCHOR BOLTS. CONTRACTOR SHALL IMMEDIATELY NOTIFY THE ENGINEER SHOULD THE PAD EXTEND OUTSIDE THE PROTECTION OF THE SHOWN BOLLARDS.
- ALL ANGLED METAL SHALL BE HOT DIPPED GALVANIZED.
- METAL ROOF SHALL BE CORRUGATED TIN AND SHALL BE A COLOR APPROVED BY THE OWNER.
- ALL METAL JOINTS/CONNECTIONS SHALL BE 1/4" FILLET WELDED ALL AROUND.
- CONTRACTOR SHALL INSTALL AN ICE BREAKING DEVICE AT SIXTEEN (16) INCH MAXIMUM INCREMENTS.

MASONRY GENERAL NOTES

- REINFORCED MASONRY WORK AND MATERIALS SHALL BE IN ACCORDANCE WITH THE BUILDING CODE REQUIREMENTS FOR MASONRY STRUCTURES ACI 530/ASCE 5/TMS 402.
- REINFORCED MASONRY SHALL CONFORM TO THE SPECIFICATIONS FOR MASONRY STRUCTURES ACI 530.1/ASCE 6/TMS 602 (UNLESS NOTED IN PROJECT SPECIFICATIONS).
- PROVIDE CONCRETE MASONRY UNITS (CMU) OF NORMAL WEIGHT (125 PCF MINIMUM), GRADE N TYPE 1, CONFORMING TO THE LATEST EDITION OF ASTM C 90. LAY UNITS IN RUNNING BOND BEAM UNLESS OTHERWISE NOTED.
- PROVIDE MASONRY MORTAR MEETING THE REQUIREMENTS OF TYPE S PER ASTM C 270. PROVIDE AGGREGATES FOR MORTAR CONFORMING TO ASTM C 404. PROVIDE MORTAR WITH A MINIMUM COMPRESSIVE STRENGTH OF 1,800 PSI AT 28 DAYS.
- PROVIDE MASONRY GROUT WITH A MINIMUM 28 DAY COMPRESSIVE STRENGTH OF 2,000 PSI TESTED IN ACCORDANCE WITH ASTM C 1019. GROUT TO MEET THE MINIMUM REQUIREMENTS SPECIFIED IN ASTM C476.
- PROVIDE MASONRY ASSEMBLAGES WITH MINIMUM PRISM STRENGTH (F_m) OF 1,500 PSI, TESTED IN ACCORDANCE WITH ASTM C 140.
- PROVIDE CONCRETE MASONRY UNITS IN ACCORDANCE WITH ASTM C 426 LIMITS FOR DRYING SHRINKAGE OF CONCRETE BLOCKS.
- PROVIDE VERTICAL REINFORCEMENT IN CMU WALLS AS SHOWN ON DRAWINGS. FILL THE REINFORCED CELLS SOLID WITH GROUT. MAXIMUM HEIGHT OF GROUT POURS TO BE AS PER ACI 530.1, TABLE 1.15.1.
- PROVIDE HORIZONTAL JOINT REINFORCING IN WALLS AT 16 INCHES ON CENTER VERTICAL SPACING. JOINT REINFORCING SHALL BE HOT DIP GALVANIZED NO. 9 GAGE LADDER TYPE WITH CROSS TIES AT 16" ON CENTER, CONFORMING TO ASTM A 82. SPACE JOINT REINFORCEMENT AT 8 INCHES ON CENTER IN THE PARAPETS. LAP SPLICE ENDS A MINIMUM OF 12 INCHES AT SPLICES.
- ALIGN VERTICAL CELLS TO BE FILLED WITH GROUT TO PROVIDE CONTINUOUS UNOBSTRUCTED VERTICAL CELLS. REMOVE OVERHANGING MORTAR OR OTHER OBSTRUCTIONS AND DEBRIS FROM THE INSIDES OF SUCH CELL WALLS. PROVIDE GROUT WITH 8 INCH SLUMP AND CONSOLIDATE BY MEANS OF HAND TAMPING TO ENSURE COMPLETE FILLING OF CELLS.
- PROVIDE AN 8 INCH HIGH BOND BEAM (MINIMUM DEPTH UNLESS OTHERWISE NOTED) AT THE TOP OF ALL CMU WALLS. REINFORCE BOND BEAMS PER DETAILS. IF BOND BEAMS AT INTERSECTING WALLS MEET AT DIFFERENT ELEVATIONS, EXTEND BOND BEAMS AROUND INTERSECTING CORNER TO FIRST INTERIOR REINFORCED CELL, BUT NOT LESS THAN 4 FEET. CONSTRUCT BOND BEAMS WITH PORTLAND CEMENT GROUT 2,000 PSI MAXIMUM COMPRESSIVE STRENGTH AT 28 DAYS AND A MAXIMUM AGGREGATE SIZE OF 1/2 INCH.
- PROVIDE VERTICAL REINFORCING AT CORNERS OF CMU WALLS, AT ENDS OF WALLS, EACH SIDE OF CONTROL JOINT AND EACH SIDE OF WALL OPENINGS PER DETAILS. PROVIDE MINIMUM 1/2 INCH THROUGH-WALL CONTROL JOINTS AT 40'-0" MAXIMUM SPACING UNLESS NOTED OTHERWISE ON DRAWINGS.
- INSTALL ANCHORS, ACCESSORIES AND OTHER ITEMS TO BE BUILT IN AS WORK PROGRESSES.
- LAP SPLICE VERTICAL REINFORCING A MINIMUM OF 40 BAR DIAMETERS OR 24 INCHES, WHICHEVER IS GREATER.
- PERFORM CUTTING AND FITTING OF MASONRY WITH MASONRY SAWS PROVIDING CUT FINISHED UNITS.
- ALL CELLS SHALL BE GROUTED SOLID.
- WHEN A FOUNDATION DOWEL DOES NOT LINE UP WITH A VERTICAL CORE, DO NOT SLOPE DOWEL MORE THAN ONE HORIZONTAL TO SIX VERTICAL.
- WHEN VERTICAL DOUBLE REINFORCED CELLS ARE SPECIFIED, PROVIDE 1/2 INCH CLEARANCE FROM INSIDE FACE OF THE BLOCK MASONRY CELL OR MINIMUM OF ONE BAR DIAMETER, WHICHEVER IS GREATER. ENSURE THAT ALL VERTICAL REINFORCING STEEL IS POSITIONED AND HELD IN PLACE BY MEANS OF WIRE SPACERS.

REFERENCE DRAWINGS

- 7.110004-C-004 ADROIT CONSTRUCTION RVTD CNG FUELING STATION PAVING, GRADING & DRAINAGE PLAN
- 7.110004-C-200 ADROIT CONSTRUCTION RVTD CNG FUELING STATION GENERAL NOTES

APPROVED FOR CONSTRUCTION
DATE: 10/12/11

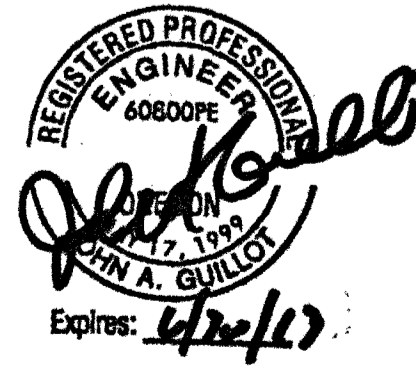

HUNT, GUILLOT & ASSOCIATES, L.L.C.
CONSULTING ENGINEERS AND PROJECT MANAGERS
P.O. BOX 580 RUSTON, LA 71273

CONFIDENTIAL
THESE DESIGNS AND DRAWINGS ARE THE EXCLUSIVE PROPERTY OF:
HUNT, GUILLOT & ASSOCIATES, RUSTON, LA.
NO COPY OR REPRODUCTION MAY BE MADE WITHOUT WRITTEN APPROVAL.

ADROIT CONSTRUCTION
RVTD CNG FUELING STATION
SECTION AND DETAILS
SHEET 1

REV.	DESCRIPTION	CHK.	DATE	APP.	DATE	SCALE	DRAWING NUMBER	REV.
0	ISSUED FOR CONSTRUCTION	CEH	10/12/11	RSO	10/12/11	AS NOTED	7.110004-C-100	0
A	ISSUED FOR APPROVAL	CEH	9/14/11	RSO	9/14/11			

DESIGNED BY	PBW	8/23/11	CHECKED BY	CEH	9/14/11
DRAWN BY	PBW	8/23/11	APPROVED BY	RSO	8/29/11
PLOT AT 1:1		DATE: 8/23/11	HGA JOB NO: 7110004 HGA ITEM NO:		

ANCHOR ROD NOTES

- ANCHOR RODS AND REINFORCING BARS, WHERE INDICATED TO BE INSTALLED USING A CHEMICAL ANCHORING SYSTEM, SHALL BE FIELD DRILLED AND INSTALLED USING THE "HILTI" HIT HY 150 ANCHORING SYSTEM OR APPROVED EQUAL. THE CONTRACTOR SHALL INSTALL PER ANCHORING SYSTEM PRODUCT INSTRUCTIONS TO FULLY DEVELOP THE ANCHOR BOLTS OR REINFORCEMENT BARS. (THIS WILL INCLUDE, BUT NOT BE LIMITED TO THE DRILLED HOLE DIAMETER AND DEPTH).
- ANCHOR RODS SHALL MEET THE REQUIREMENTS OF ASTM F1554, GRADE 36 UNLESS OTHERWISE NOTED.
- ALL ANCHOR RODS AND NUTS SHALL BE HOT DIPPED GALVANIZED PER ASTM A123 WITH NUTS RETAPPED.
- ANCHOR RODS SHALL BE FURNISHED WITH HEX NUTS AND CUT WASHERS OF SPECIFICATIONS COMPATIBLE WITH THOSE OF THE THREADED SHANKS UNLESS OTHERWISE NOTED. MINIMUM WASHER SIZE AND THICKNESS SHALL COMPLY WITH THE AISC MANUAL OF STEEL CONSTRUCTION.
- ANCHOR RODS SHALL BE CLEAN AND FREE OF ANY OILS OR OTHER FOREIGN MATERIALS PRIOR TO PLACEMENT.
- MEANS SHALL BE USED TO PREVENT CONCRETE FROM CONTACTING THE PROJECTING PART OF THE ANCHOR ROD.

REFERENCE DRAWINGS

- 7.110004-C-003 ADROIT CONSTRUCTION
RVID CNG FUELING STATION
PAVING, GRADING & DRAINAGE PLAN
- 7.110004-C-200 ADROIT CONSTRUCTION
RVID CNG FUELING STATION
GENERAL NOTES

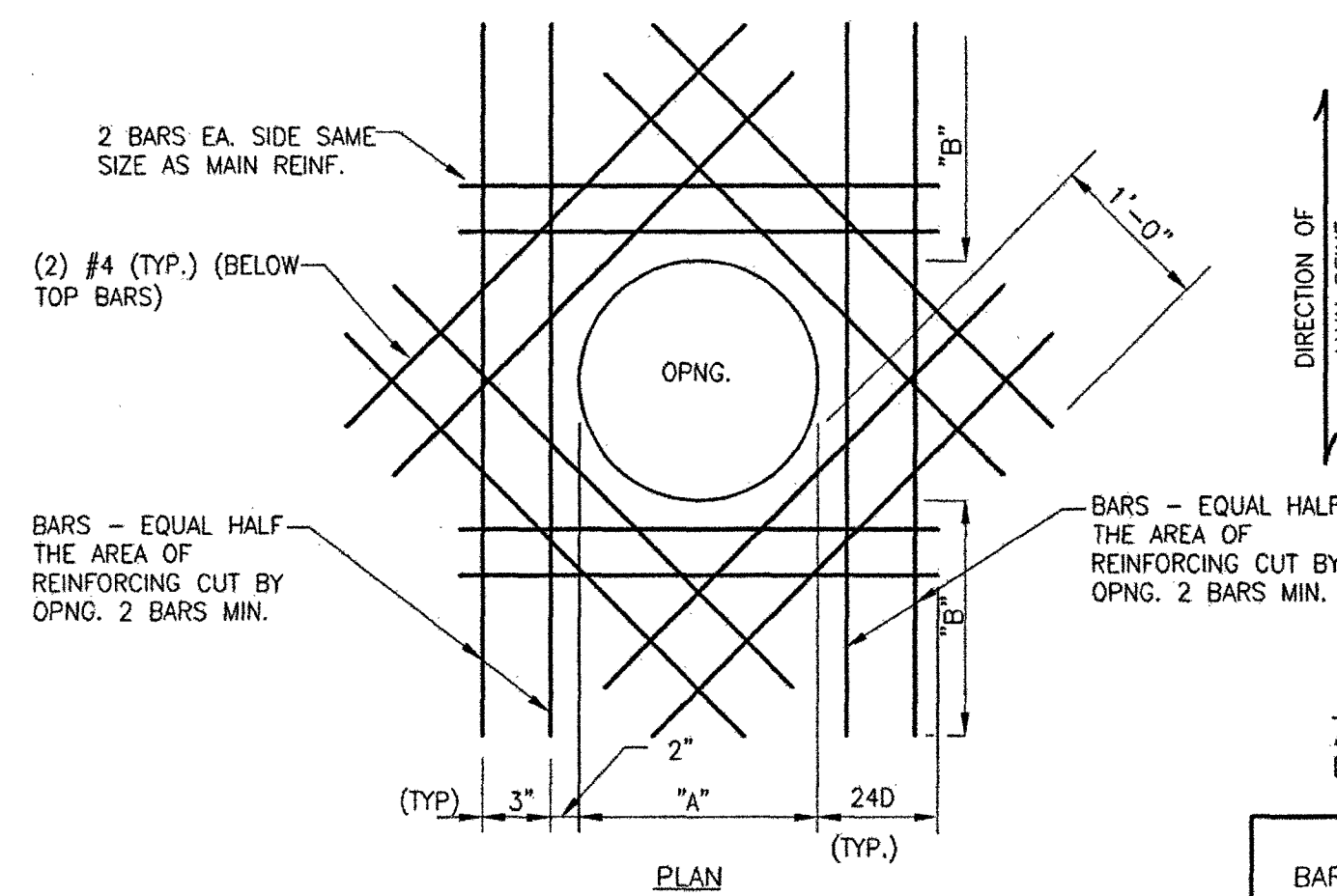
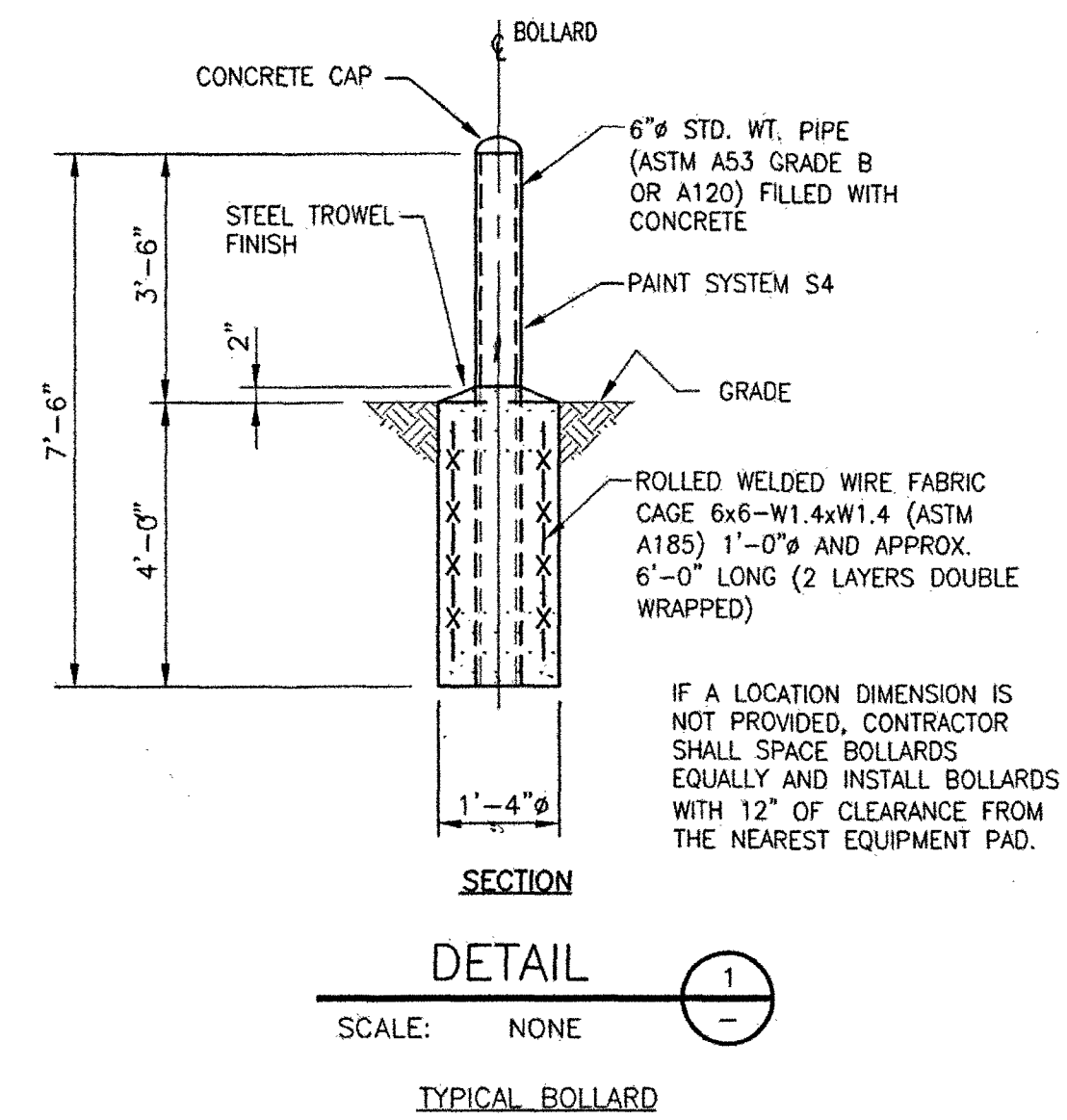

DETAIL 2
SCALE: NONE
OPENINGS THRU SLAB WHERE "A" IS BETWEEN 1'-0" & 4'-0"

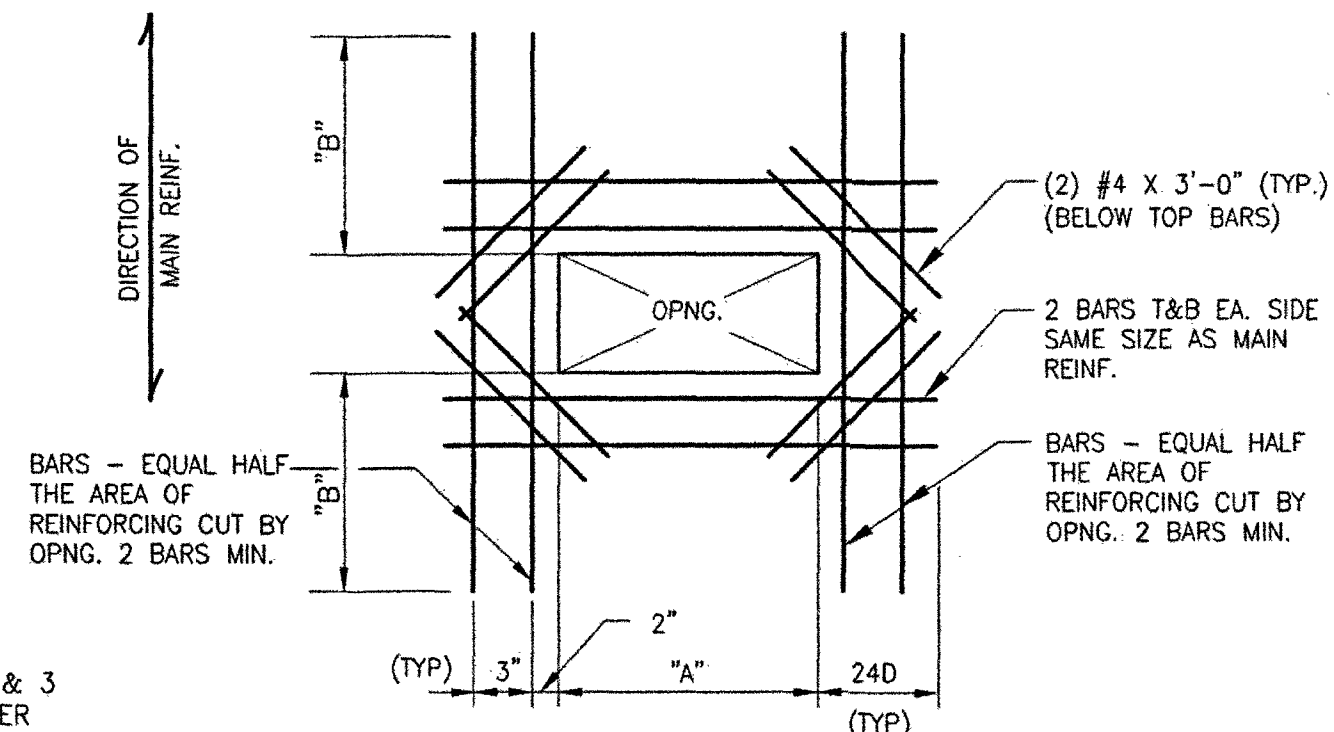

DETAIL 3
SCALE: NONE
OPENINGS THRU SLAB WHERE "A" IS BETWEEN 1'-0" & 4'-0"

NOTE: AT DETAILS 2 & 3 D=BAR DIAMETER

BAR SIZE	"B" DIMENSION	
	*TOP BAR	*BOT BAR
3	1'-4"	1'-0"
4	1'-9"	1'-4"
5	2'-8"	2'-1"
6	3'-10"	3'-0"

* IF "B" DIMENSION CANNOT BE OBTAINED, USE 180° HOOK

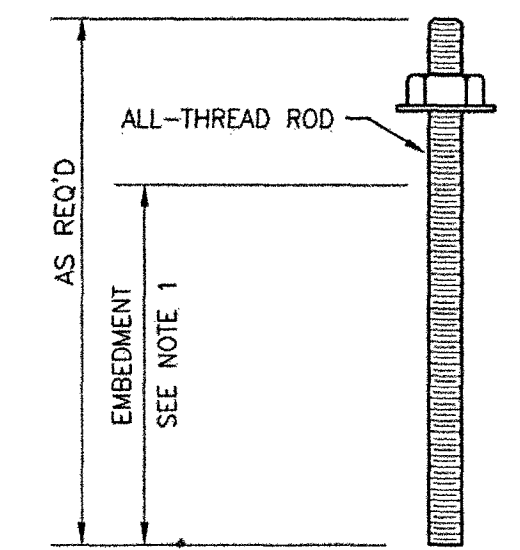

DETAIL 4
SCALE: NONE
TYPE "E" ANCHOR RODS USING CHEMICAL ANCHORING SYSTEM

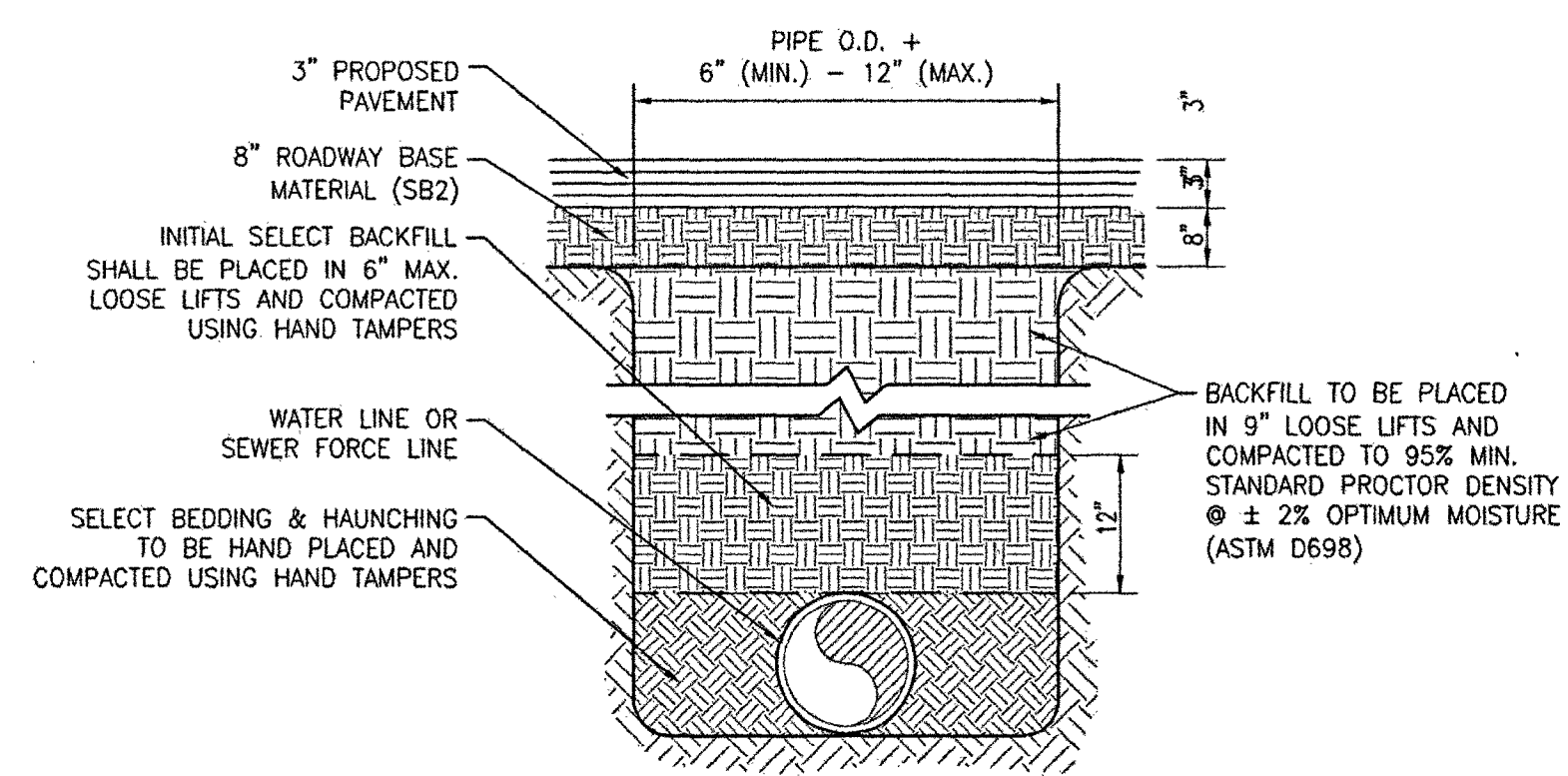

NOTE: THIS DETAIL SHALL APPLY AT ALL PROPOSED IMPROVED SURFACES. FOUNDATION SHALL EXTEND A MINIMUM OF 2' BEYOND BACK OF CURBS
BEDDING DETAIL AT IMPROVED ASPHALT SURFACES

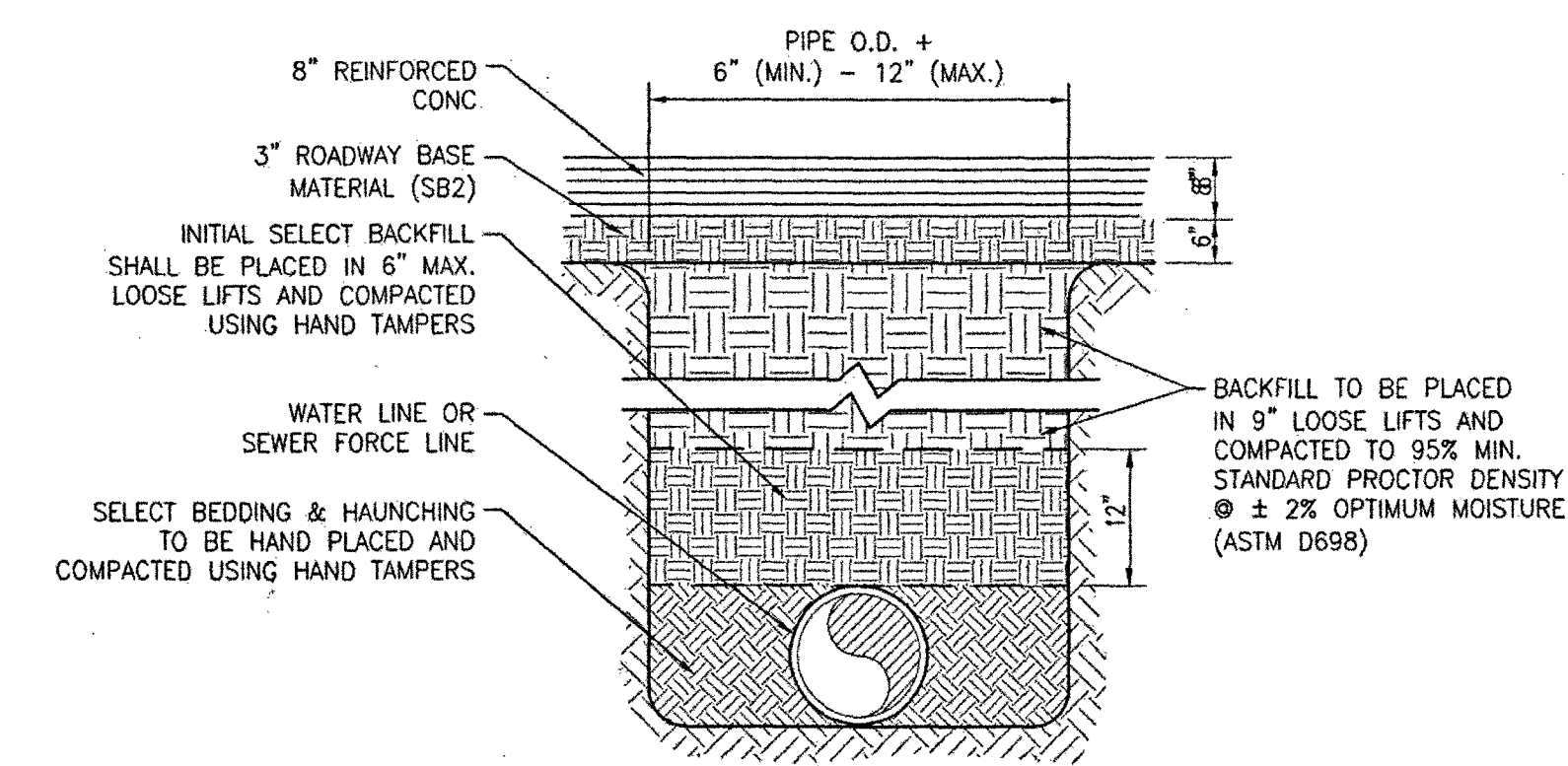

NOTE: THIS DETAIL SHALL APPLY AT ALL PROPOSED IMPROVED SURFACES. FOUNDATION SHALL EXTEND A MINIMUM OF 2' BEYOND BACK OF CURBS
BEDDING DETAIL AT IMPROVED CONCRETE SURFACES

STANDARD PIPE/CONDUIT BEDDING DETAILS
SCALE: N.T.S.

APPROVED FOR CONSTRUCTION
DATE: 10/12/11

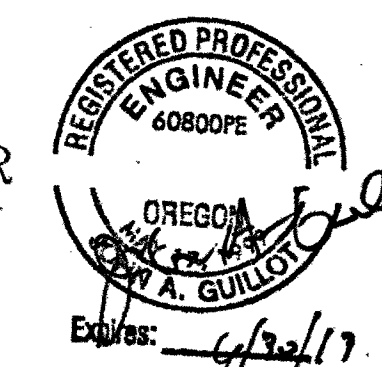

HUNT, GUILLOT & ASSOCIATES, L.L.C.
CONSULTING ENGINEERS AND PROJECT MANAGERS
P.O. BOX 580 RUSTON, LA 71275
MOBILE: _____

CONFIDENTIAL
THESE DESIGNS AND DRAWINGS ARE THE EXCLUSIVE PROPERTY OF:
HUNT, GUILLOT & ASSOCIATES, RUSTON, LA.
NO COPY OR REPRODUCTION MAY BE MADE WITHOUT WRITTEN APPROVAL.

ADROIT CONSTRUCTION
RVID CNG FUELING STATION
SECTION AND DETAILS
SHEET 2

DESIGNED BY	PBW	8/23/11	CHECKED BY	CEH	9/14/11
DRAWN BY	PBW	8/23/11	APPROVED BY	RSO	9/14/11
PLOT AT 1: 1	DATE:	8/23/11	HGA JOB NO:	7110004	HGA ITEM NO:
SCALE	AS NOTED	DRAWING NUMBER	7.110004-C-101	REV.	0
REV.	DESCRIPTION	CHK.	DATE	APP.	DATE

GENERAL SITE PLAN NOTES

- LOCATIONS, ELEVATIONS, AND DIMENSIONS OF EXISTING UTILITIES, STRUCTURES, AND OTHER FEATURES ARE SHOWN ACCORDING TO THE BEST INFORMATION AVAILABLE AT THE TIME OF PREPARATION OF THESE PLANS. THE CONTRACTOR SHALL VERIFY THE LOCATIONS, ELEVATIONS, AND DIMENSIONS OF ALL EXISTING UTILITIES, STRUCTURES, AND OTHER FEATURES, AFFECTING THIS WORK, PRIOR TO CONSTRUCTION.
- PRIOR TO THE INITIATION OF SITE CONSTRUCTION, THE CONTRACTOR SHALL VERIFY ANY EXISTING UTILITIES INCLUDING GAS, WATER, ELECTRIC, COMMUNICATIONS, CABLE TV, SANITARY, AND STORM SEWERS ON AND/OR ADJACENT TO THE SITE.
- THE CONTRACTOR SHALL EXERCISE EXTREME CAUTION IN AREAS OF BURIED UTILITIES AND SHALL CALL "ONE CALL" (811) OR UTILITY COMPANY AT LEAST 48 HOURS PRIOR TO CONSTRUCTION TO ARRANGE FOR FIELD LOCATIONS OF BURIED UTILITIES.
- THE CONTRACTOR IS RESPONSIBLE FOR REPAIRING ANY DAMAGE TO EXISTING FACILITIES, ABOVE OR BELOW GROUND THAT MAY OCCUR AS A RESULT OF THE WORK PERFORMED BY THE CONTRACTOR OR SUBCONTRACTORS.
- IT IS THE CONTRACTOR'S RESPONSIBILITY TO BECOME FAMILIAR WITH THE PERMIT AND INSPECTION REQUIREMENTS SPECIFIED BY THE VARIOUS GOVERNMENTAL AGENCIES AND THE ENGINEER.
- SAFETY:
 - DURING THE CONSTRUCTION AND/OR MAINTENANCE OF THIS PROJECT, ALL SAFETY REGULATIONS ARE TO BE ENFORCED. THE CONTRACTOR, OR HIS REPRESENTATIVE SHALL BE RESPONSIBLE FOR THE CONTROL AND SAFETY OF THE TRAVELING PUBLIC AND THE SAFETY OF HIS/HER PERSONNEL.
 - LABOR SAFETY REGULATIONS SHALL CONFORM TO THE PROVISIONS SET FORTH BY OSHA IN THE FEDERAL REGISTER OF THE DEPARTMENT OF TRANSPORTATION.
 - THE MINIMUM STANDARDS AS SET FORTH BY THE DOTD SHALL BE FOLLOWED IN THE DESIGN, APPLICATION, INSTALLATION, MAINTENANCE, AND REMOVAL OF ALL TRAFFIC CONTROL DEVICES, WARNING DEVICES, AND BARRIERS NECESSARY TO PROTECT THE PUBLIC AND CONSTRUCTION PERSONNEL FROM HAZARDS WITHIN THE PROJECT LIMITS.
 - ALL TRAFFIC CONTROL MARKINGS AND DEVICES SHALL CONFORM TO THE PROVISIONS SET FORTH IN THE MANUAL ON UNIFORM TRAFFIC CONTROL DEVICES PREPARED BY THE U.S. DEPARTMENT OF TRANSPORTATION FEDERAL HIGHWAY ADMINISTRATION.
 - ALL SUBSURFACE CONSTRUCTION SHALL COMPLY WITH THE "TRENCH SAFETY ACT", THE CONTRACTOR SHALL INSURE THAT THE METHOD OF TRENCH PROTECTION AND CONSTRUCTION IS IN COMPLIANCE WITH THE OCCUPATIONAL SAFETY AND HEALTH ADMINISTRATION (OSHA) REGULATIONS.
- IT SHALL BE THE SOLE RESPONSIBILITY OF THE CONTRACTOR TO COMPLY WITH AND ENFORCE ALL APPLICABLE SAFETY REGULATIONS. THE ABOVE INFORMATION HAS BEEN PROVIDED FOR THE CONTRACTOR'S INFORMATION ONLY AND DOES NOT IMPLY THAT THE OWNER OR ENGINEER WILL INSPECT AND/OR ENFORCE SAFETY REGULATIONS.
- A QUALIFIED TESTING LABORATORY SHALL PERFORM ALL TESTING NECESSARY TO ASSURE COMPLIANCE OF THE IN-PLACE MATERIALS AS REQUIRED BY THE PLANS, THE VARIOUS AGENCIES AND PERMIT CONDITIONS. SHOULD ANY RETESTING BE REQUIRED DUE TO THE FAILURE OF ANY TESTS TO MEET THE REQUIREMENTS, THE CONTRACTOR WILL BEAR ALL COSTS OF SAID RETESTING.
- IN ACCORDANCE WITH GENERALLY ACCEPTED CONSTRUCTION PRACTICES, THE CONTRACTOR WILL BE SOLELY AND COMPLETELY RESPONSIBLE FOR CONDITIONS OF THE JOB SITE, INCLUDING SAFETY OF ALL PERSONS AND PROPERTY DURING PERFORMANCE OF THE WORK. THIS REQUIREMENT WILL APPLY CONTINUOUSLY AND NOT LIMITED TO NORMAL WORKING HOURS.
- THE CONTRACTOR SHALL THOROUGHLY REVIEW ALL PLANS AND SPECIFICATIONS, SHALL PREPARE DETAILED MATERIAL QUANTITIES AND COSTS ACCORDINGLY BEFORE SUBMITTING HIS BID. ANY WORK CONSTRUCTION MATERIALS, FITTINGS, AND APPURTENANCES REQUIRED BY THE PLANS AND SPECIFICATIONS, (INCLUDING FITTINGS AND MATERIALS AT ALL TIE-IN POINTS) AND NOT OTHERWISE IDENTIFIED AS A PAY ITEM OR A MATERIAL TAKE-OFF ITEM, SHALL BE DEEMED INCIDENTAL TO CONSTRUCTION AND SHALL BE PREFORMED, SUPPLIED AND INSTALLED AT NO ADDITIONAL PAY.
- THE CONTRACTOR SHALL PROVIDE TEMPORARY UTILITIES SUCH AS ELECTRICITY AND WATER.
- IMPORTED BACKFILL SHALL BE PAID FOR BASED ON THE ACTUAL VOLUME OF CUBIC YARDS INSTALLED IN THE FIELD, WITHIN THE TRENCH OR PAVEMENT SECTION LIMITS SHOWN IN THE PLANS AS GIVEN IN THE OREGON STANDARD SPECIFICATIONS FOR CONSTRUCTION, PER THE UNIT RATE IN THE CONTRACTOR'S BID PROPOSAL. IF MEASUREMENT IS CALCULATED BY VEHICULAR MEASUREMENT, THE AMOUNT SHALL BE ADJUSTED BY DIVIDING THE MEASURED QUANTITY BY 1.30 SHRINKAGE FACTOR.
- THE CONTRACTOR SHALL RESTORE IN KIND EXISTING LANDSCAPING DISTURBED DUE TO CONSTRUCTION. THIS SHALL INCLUDE, BUT NOT LIMITED TO TREES, SHRUBS, FLOWERS, SOLID SOD, BEDDING MATERIAL(SOIL) AND SPRINKLER SYSTEM APPURTENANCES. DISTURBED AREAS MUST BE SEEDED AND FERTILIZED UNLESS NOTED AS SOLID SOD ON THESE PLANS. FINAL PAYMENT FOR THIS ITEM WILL BE UPON NO EROSION AND THE ESTABLISHMENT OF AN ADEQUATE STAND OF PERMANENT GRASS AS DEEMED SATISFACTORY BY THE OWNER.
- THE CONTRACTOR SHALL MAINTAIN WATER AND SEWER SERVICE (IF APPLICABLE) AT ALL TIMES DURING CONSTRUCTION.
- THE CONTRACTOR SHALL BE RESPONSIBLE FOR SECURING THE NECESSARY CITY, STATE AND PARISH PERMITS FROM CONTROLLING AGENCIES REQUIRED FOR CONSTRUCTION OF THIS PROJECT. THE PERMIT SHALL BE OBTAINED IN THE NAME OF THE OWNER.
- THE CONTRACTOR IS RESPONSIBLE FOR REESTABLISHING EXISTING DRAINAGE CONDITIONS.
- THE CONTRACTOR MUST MAINTAIN LOCAL TRAFFIC ALONG STREETS AND ACROSS INTERSECTIONS. THE CONTRACTOR SHALL BE INSTALL TEMPORARY TRAFFIC MAINTENANCE AGGREGATE FOR LOCAL TRAFFIC. THE CONTRACTOR SHALL BE RESPONSIBLE FOR PLACEMENT OF SIGNS AND BARRICADES AS REQUIRED UNTIL COMPLETION OF CONSTRUCTION TO INSURE SAFE WORKING CONDITIONS FOR CONSTRUCTION PERSONNEL AS WELL AS SAFE DRIVING CONDITIONS FOR THE GENERAL PUBLIC. THE USE OF FLAGMEN SHALL BE UTILIZED AT THE DISCRETION OF THE CONTRACTOR. TRAFFIC SHALL BE MAINTAINED IN ACCORDANCE WITH ALL CURRENT REGULATIONS SPECIFIED BY THE MANUAL OF UNIFORM TRAFFIC CONTROL DEVICES (MUTCD).
- THE CONTRACTOR SHALL BE RESPONSIBLE FOR LAYOUT AND ALIGNMENT OF THE PROPOSED PROJECT.
- CONTRACTOR SHALL BE RESPONSIBLE FOR THE DEVELOPMENT AND DEPLOYMENT OF A TEMPORARY EROSION CONTROL PLAN THAT MEETS ALL APPLICABLE LOCAL, STATE & FEDERAL GOVERNMENT REGULATION. PLAN SHALL BE SUBMITTED TO ENGINEER FOR APPROVAL PRIOR TO START OF CONSTRUCTION.
- ALL TRENCH AND OTHER EXCAVATIONS SHALL BE IN STRICT ACCORDANCE WITH OSHA REGULATIONS AND APPLICABLE LOCAL CODES AND ORDINANCES.
- CONTRACTOR SHALL MAINTAIN ONE SET OF "RECORD DRAWINGS" AT THE PROJECT SITE AT ALL TIMES. ALL LOCATIONS OF UTILITIES (INCLUDING SERVICE LINES), ENGINEER APPROVED CHANGES AND ANY DEVIATIONS FROM THE PLANS SHALL BE CLEARLY MARKED ON THE DRAWINGS. CONTRACTOR SHALL DELIVER TO ENGINEER WHEN UTILITY IMPROVEMENT INSTALLATIONS ARE COMPLETE. ENGINEER SHALL PROVIDE ONE FINAL COPY OF THE RECORD DRAWING TO ADROIT CONSTRUCTION FOR OWNER'S PERMANENT RECORDS.
- CONTRACTOR SHALL PERFORM ALL WORK AS REQUIRED TO PROTECT THE ADJOINING PROPERTY, STREETS, SIDEWALKS, ETC. FROM DAMAGE.
- CONTRACTOR SHALL NOTIFY ENGINEER, OWNER, AND LOCAL MUNICIPALITY (WATER & SEWER DEPT., ELECTRICAL DEPT., AS APPROPRIATE) 48 HOURS PRIOR TO CONSTRUCTION, TESTING AND OTHER OPERATIONS AS REQUIRED BY NOTES ON PLANS. CONTRACTOR IS SPECIFICALLY CAUTIONED THAT FAILURE TO NOTIFY ENGINEER AND/OR OWNER MAY RESULT IN UNCOVERING AND/OR RE-INSTALLING AND/OR REPLACEMENT OF UTILITY IMPROVEMENTS TO THE ENGINEER'S AND OWNER'S SATISFACTION AT CONTRACTOR'S COST (NO COST TO OWNER OR ENGINEER). CONTRACTOR'S START OF WORK AT JOB SITE MEANS CONTRACTOR HAS READ AND AGREED TO THESE CONDITIONS.

GENERAL GRADING NOTES:

- SELECT FILL MATERIAL PLACED DURING CONSTRUCTION SHALL MEET REQUIREMENTS FOR TYPE OF MATERIAL, PLACEMENT AND COMPACTION SPECIFIED IN THE DOTD STANDARD SPECIFICATIONS.
- THE ENTIRE CONSTRUCTION AREA SHALL BE STRIPPED OF ORGANIC MATERIAL AND PROOF ROLLED PRIOR TO PLACEMENT OF FILL. AREAS OF UNSTABLE SOIL SHALL BE REMOVED AND REPLACED AS DIRECTED BY THE ENGINEER. EXCAVATED MATERIAL NOT USED FOR FILL ON SITE SHALL BE TESTED FOR CONTAMINATION AS REQUESTED BY ENGINEER. CONTAMINATED MATERIAL SHALL BE PROPERLY DISPOSED OF AT A PERMITTED LANDFILL.
- SELECT FILL SHALL BE PLACED ON PREPARED SUBGRADE IN 8" LOOSE LIFTS AND COMPACTED TO 95% STANDARD PROCTOR DENSITY OR AS DIRECTED BY PROJECT ENGINEER. COMPACTION TESTS WILL BE REQUIRED FOR EACH LIFT.
- THE CONTRACTOR SHALL PROVIDE, INSTALL AND MAINTAIN EROSION CONTROL DEVICES AS SHOWN IN THE EROSION CONTROL PLAN TO PREVENT SILTATION OF ADJACENT PROPERTY AND DRAINAGE FACILITIES PRIOR TO ANY SITE WORK. ANY SILTATION OF ADJACENT PROPERTY WILL BE REMOVED PRIOR TO FINAL ACCEPTANCE BY OWNER.
- ALL EXISTING DEBRIS WITHIN CONSTRUCTION LIMITS (ABOVE OR BELOW GROUND), CONSTRUCTION DEBRIS AND OTHER WASTE MATERIAL SHALL BE DISPOSED OF OFF-SITE BY THE CONTRACTOR IN ACCORDANCE WITH APPLICABLE REGULATORY AGENCY REQUIREMENTS.

SITE DESIGN CRITERIA

- THE OREGON 2010 STRUCTURAL SPECIALTY CODE SECTION 1613 IS USED TO DESIGN FOR EARTHQUAKE LOADS.
- THE DESIGN WIND SPEED IS 94.5 MILES PER HOUR (3-SECOND GUST) IN ACCORDANCE WITH THE OREGON 2010 STRUCTURAL SPECIALTY CODE; SEE SECTION 1609.3.1 FOR ADDITION DESIGN INFORMATION.
 - WIND EXPOSURE CATEGORY: B
- SOIL BEARING PRESSURE: 1,500 POUNDS PER SQUARE FOOT.
- ROOF SNOW LOAD IS 20 POUNDS PER SQUARE FOOT, NO DRIFTING REQUIREMENTS
- RAINFALL DESIGN IS BASED ON TWO INCHES PER HOUR.
- THE FROST DEPTH IS 12"

CONCRETE NOTES:

- ALL CONCRETE USED FOR PAVEMENT, CURB, DRAINAGE STRUCTURES AND MISCELLANEOUS CONSTRUCTION SHALL ATTAIN A MINIMUM ULTIMATE COMPRESSIVE STRENGTH OF 4000 PSI AT 28 DAYS.
- NO CONCRETE SHALL BE PLACED WITHOUT PRIOR APPROVAL OF THE ENGINEER. INSPECTOR SHALL BE ON SITE FOR ALL CONCRETE POURS, 48 HOURS PRIOR NOTICE REQUIRED BEFORE ALL CONCRETE POURS.
- ALL CONCRETE PAVEMENT JOINTS SHALL BE CLEANED AND SEALED WITH POLYURETHANE OR SILICONE POLYMER JOINT SEALER.
- CONTRACTOR TO PROVIDE A 3/4" BITUMINOUS EXPANSION JOINT MATERIAL WITH SEALER AT ALL CONCRETE EXPANSION JOINTS AND AT ABUTMENT OF CONCRETE AND OTHER MATERIALS (DRAINAGE STRUCTURES, OTHER POURED CONCRETE, ETC.).
- CONCRETE AGGREGATE SHALL CONFORM TO ODOT STANDARD SPECIFICATIONS.
- ALL REINFORCING BARS SHALL BE NEW BILLET INTERMEDIATE GRADE DEFORMED BARS CONFORMING TO A.S.T.M. A-615 AND SHALL HAVE A MINIMUM YIELD STRENGTH OF 60 KSI.
- REINFORCING BARS AND WELDED WIRE FABRIC (W.W.F.) SHALL BE TIED AND HELD AT POSITIONS SHOWN ON THE DETAILS BY USE OF STEEL WIRE BAR SUPPORTS. SUITABLE BOTTOM PLATES SHALL BE PROVIDED TO PREVENT DISPLACEMENT OF THE SUPPORT FOOT WHERE BAR SUPPORTS ARE USED ON EARTH OR AGGREGATE SUBGRADE.
- EXPOSED CONCRETE CORNERS SHALL BE CHAMFERED 3/4" UNLESS OTHERWISE NOTED.
- CONTRACTOR SHALL CONTACT ODOT OR CITY PRIOR TO BEGINNING CONSTRUCTION WITHIN STATE OR CITY RIGHT-OF-WAY. THE STATE REQUIREMENTS FOR CONSTRUCTION SIGNING SHALL BE FOLLOWED WHILE WORK IS BEING PERFORMED WITHIN STATE OR CITY R.O.W.
- BASE COURSE SHALL BE PROVIDED IN ACCORDANCE WITH ODOT STANDARD SPECIFICATIONS OR AS SPECIFIED IN THESE PLANS.

UTILITY NOTES:

- CONTRACTOR IS RESPONSIBLE FOR VERIFYING ALL UTILITIES AND NOTIFYING THE APPROPRIATE UTILITY COMPANY PRIOR TO BEGINNING CONSTRUCTION.
- THE CONTRACTOR IS SPECIFICALLY CAUTIONED THAT THE LOCATION AND/OR ELEVATION OF EXISTING UTILITIES AS SHOWN ON THESE PLANS IS BASED ON RECORDS OF THE VARIOUS UTILITY COMPANIES AND, WHERE POSSIBLE, MEASUREMENTS TAKEN IN THE FIELD. THE INFORMATION IS NOT TO BE RELIED ON AS BEING EXACT OR COMPLETE. THE CONTRACTOR MUST CALL THE APPROPRIATE UTILITY COMPANY AT LEAST 48 HOURS BEFORE ANY EXCAVATION TO REQUEST EXACT FIELD LOCATION OF THE UTILITIES. IT SHALL BE THE RESPONSIBILITY OF THE CONTRACTOR TO RELOCATE ALL EXISTING UTILITIES WHICH CONFLICT WITH THE PROPOSED IMPROVEMENTS SHOWN ON THE PLANS.
- CONTRACTOR SHALL VERIFY HORIZONTAL AND VERTICAL LOCATION OF ALL EXISTING STORM SEWER STRUCTURES, PIPES, AND ALL UTILITIES PRIOR TO CONSTRUCTION.
- CONTRACTOR IS RESPONSIBLE FOR REPAIRS OF DAMAGE TO ANY EXISTING IMPROVEMENTS DURING CONSTRUCTION, SUCH AS, BUT NOT LIMITED TO, UTILITIES, PAVEMENT, STRIPING, CURBS, ETC. REPAIRS SHALL BE EQUAL TO OR BETTER THAN EXISTING CONDITION.
- CONTRACTOR SHALL COORDINATE INSTALLATION OF UTILITIES IN SUCH A MANNER AS TO AVOID CONFLICTS AND ASSURE PROPER DEPTHS ARE ACHIEVED AS WELL AS COORDINATING WITH CITY UTILITY REQUIREMENTS AS TO LOCATIONS AND SCHEDULING FOR TIE-INS/CONNECTIONS PRIOR TO CONNECTING EXISTING FACILITIES.
- CONSTRUCTION SHALL COMPLY WITH ALL GOVERNING CODES AND BE CONSTRUCTED TO SAME.
- SEE PLANS AND SPECIFICATIONS FOR BACKFILLING AND COMPACTION REQUIREMENTS ON UTILITY TRENCHES.
- CONTRACTOR SHALL COMPLY TO THE FULLEST EXTENT WITH THE LATEST STANDARD OF OSHA DIRECTIVES OR ANY OTHER AGENCY HAVING JURISDICTION FOR EXCAVATION AND TRENCHING PROCEDURES. THE CONTRACTOR SHALL USE SUPPORT SYSTEMS, SLOPING, BENCHING, AND OTHER MEANS OF PROTECTION. THIS TO INCLUDE BUT NOT LIMITED TO, ACCESS AND EGRESS FROM ALL EXCAVATION AND TRENCHING.
- CONTRACTOR SHALL COORDINATE WITH OTHER UTILITIES AS TO ASSURE PROPER DEPTH AND PREVENT ANY CONFLICT OF UTILITIES.
- CONTRACTOR SHALL GROUT AROUND ALL PIPE ENTRANCES TO SANITARY SEWER MANHOLES AND STORM DRAIN BOXES WITH NON-SHRINKING GROUT TO ASSURE CONNECTION IS WATER TIGHT.
- WATER SERVICES, CONNECTIONS, AND INSTALLATIONS SHALL BE COMPLETED BY A OREGON LICENSED PLUMBER.

LANDSCAPING NOTES:

- THE CONTRACTOR SHALL RESTORE IN KIND EXISTING LANDSCAPING DISTURBED DUE TO CONSTRUCTION. THIS SHALL INCLUDE, BUT NOT LIMITED TO TREES, SHRUBS, FLOWERS, SOLID SOD, BEDDING MATERIAL(SOIL) AND SPRINKLER SYSTEM APPURTENANCES. DISTURBED AREAS MUST BE SEEDED AND FERTILIZED UNLESS NOTED AS SOLID SOD ON THESE PLANS. FINAL PAYMENT FOR THIS ITEM WILL BE UPON NO EROSION AND THE ESTABLISHMENT OF AN ADEQUATE STAND OF PERMANENT GRASS AS DEEMED SATISFACTORY BY THE OWNER.
- CONTRACTOR SHALL SOLID SOD ALL DISTURBED, NON-PAVED, AREAS WITHIN 7 DAYS OF LAST CONSTRUCTION AND MAINTAIN FOR AT LEAST 30 DAYS. SODDING SHALL BE IN ACCORDANCE WITH OREGON STANDARD SPECIFICATIONS FOR CONSTRUCTION, 2008 EDITION.
- CONTRACTOR SHALL APPLY FERTILIZER TO ALL SOLID SOD AREAS IN ACCORDANCE WITH THE OREGON STANDARD SPECIFICATIONS FOR CONSTRUCTION, 2008 EDITION.
- ALL TREES SHALL BE IN ACCORDANCE WITH THE CITY OF MEDFORD STANDARDS AND SHALL BE APPROVED TO BE PLACED BENEATH A POWER LINE.

APPROVED FOR CONSTRUCTION

DATE: 10/12/11

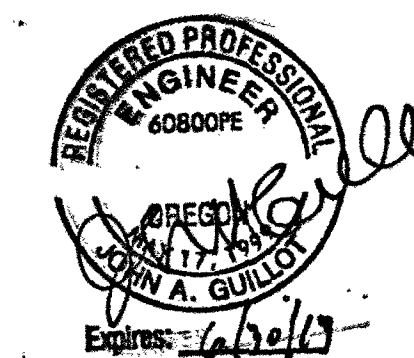

HUNT, GUILLOT & ASSOCIATES, L.L.C.
CONSULTING ENGINEERS AND PROJECT MANAGERS
P.O. BOX 580 RUSTON, LA 71273

CONFIDENTIAL
THESE DESIGNS AND DRAWINGS ARE THE EXCLUSIVE PROPERTY OF:
HUNT, GUILLOT & ASSOCIATES, RUSTON, LA.
NO COPY OR REPRODUCTION MAY BE MADE WITHOUT WRITTEN APPROVAL.

ADROIT CONSTRUCTION
RVTD CNG FUELING STATION
GENERAL NOTES

DESIGNED BY	PBW	8/23/11	CHECKED BY	CEH	9/14/11
DRAWN BY	PBW	8/23/11	APPROVED BY	RSO	9/14/11
PLOT AT 1: 1		DATE: 8/23/11	HGA JOB NO: 7110004 HGA ITEM NO:		
SCALE	DRAWING NUMBER		REV.		
NTS	7.110004-C-200		0		

REV.	DESCRIPTION	CHK.	DATE	APP.	DATE
0	ISSUED FOR CONSTRUCTION	CEH	10/12/11	RSO	10/12/11
A	ISSUED FOR APPROVAL	CEH	9/14/11	RSO	9/14/11

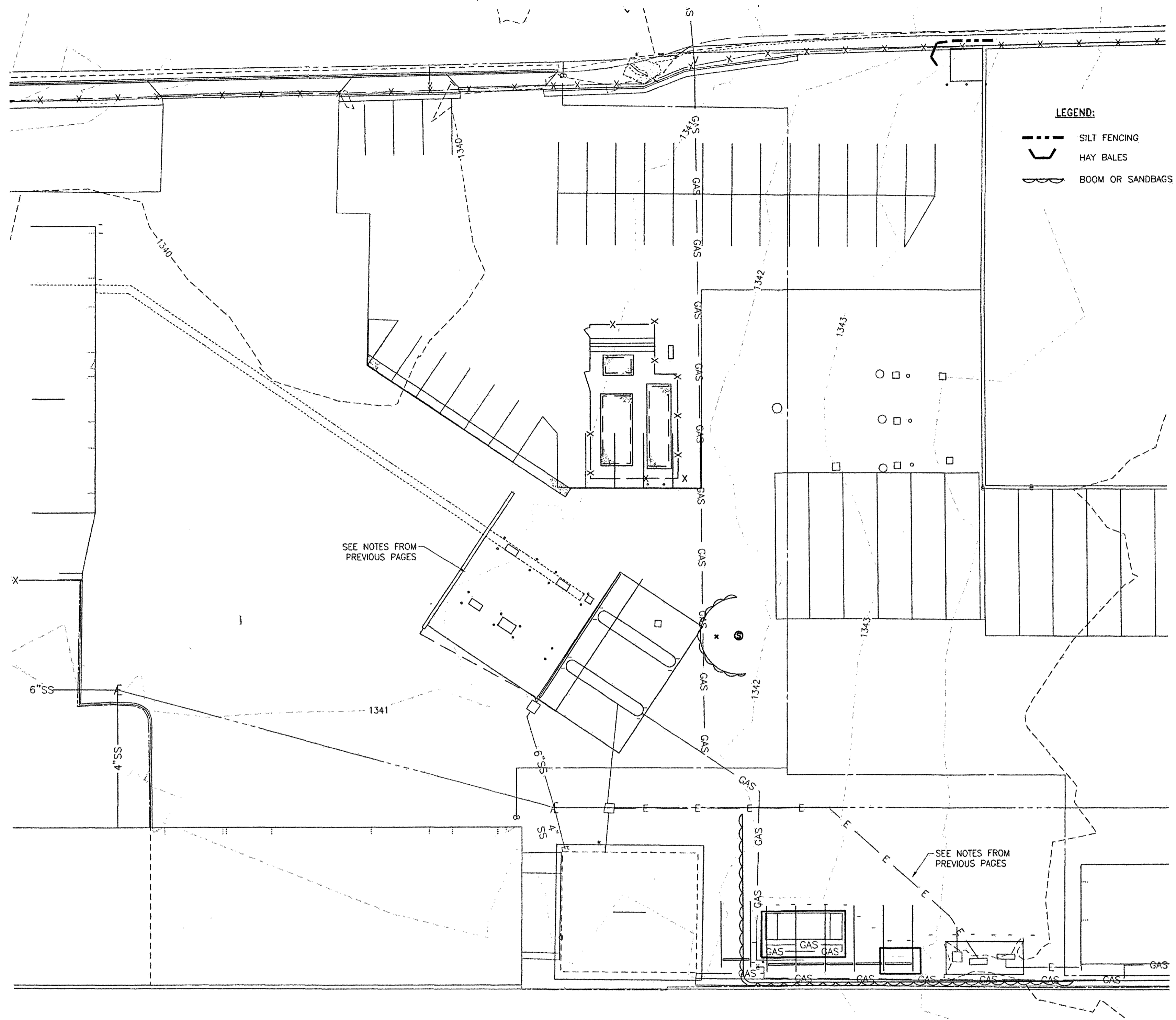

GENERAL NOTES:

1. CONTRACTOR WILL MAINTAIN ALL EROSION CONTROL MEASURES AS OUTLINED IN THE STORM WATER POLLUTION PREVENTION PLAN.
2. CONTRACTOR SHALL BE RESPONSIBLE FOR REMOVAL OF MUD TRACKED ONTO PUBLIC RIGHT-OF-WAY ON A TIMELY BASIS.
3. RIP-RAP & FILTER FABRIC SHALL BE INSTALLED AT OUTFLOWS WHERE EROSION IS ANTICIPATED. ENGINEER TO IDENTIFY THESE LOCATIONS DURING CONSTRUCTION.
4. ADDITIONAL PROTECTION: CONTRACTOR IS RESPONSIBLE FOR INSTALLING AND MAINTAINING ANY ADDITIONAL EROSION CONTROL MEASURES OTHER THAN THOSE SHOWN ON THESE PLANS TO INSURE THAT SEDIMENT IS CONFINED TO THE SITE.
5. IF THE ACTION OF VEHICLES TRAVELING OVER THE CRUSHED STONE CONSTRUCTION EXIT POINT IS NOT SUFFICIENT TO REMOVE THE MAJORITY OF DIRT AND MUD FROM THE EXITING TRAFFIC, THE CONTRACTOR SHALL PROVIDE HOSE BIBS AT THE EXIT POINT AND WASH TIRES BEFORE THE VEHICLES ENTER A PUBLIC ROAD. PROVISIONS SHALL BE MADE TO INTERCEPT THE WASH WATER AND TRAP THE SEDIMENT BEFORE IT IS CARRIED OFF THE SITE.
6. IF SOIL STOCKPILING IS USED ON THE SITE, SILT FENCES SHALL BE USED TO CONTROL AND CONTAIN THE SEDIMENT.
7. TEMPORARY EROSION AND SEDIMENT CONTROL MEASURES SHALL BE REMOVED AND DISPOSED OF WITHIN 30 DAYS AFTER FINAL STABILIZATION. FINAL STABILIZATION HAS OCCURRED WHEN ALL SOIL DISTURBING ACTIVITIES ARE COMPLETED AND A UNIFORM PERENNIAL VEGETATIVE COVER WITH A DENSITY OF 70% FOR UNPAVED AREAS AND AREAS NOT COVERED BY PERMANENT STRUCTURES HAS BEEN ESTABLISHED.
8. THE EROSION CONTROL PLAN IS TO BE USED BY THE CONTRACTOR AS A MINIMUM GUIDELINE AND SHALL NOT BE USED AS A CONCLUSIVE OUTLINE. THE CONTRACTOR SHALL BE RESPONSIBLE FOR PROVIDING ADDITIONAL EROSION CONTROL METHODS AND/OR PRODUCTS NEEDED DUE TO UNFORESEEN CONSTRUCTION PROCEDURES.
9. ALL SEDIMENT SPILLED, DROPPED, WASHED OR TRACKED ONTO PUBLIC RIGHT-OF-WAY MUST BE REMOVED IN A TIMELY MANNER.
10. USE SAND BAGS, GRAVEL, BOARDS OR OTHER APPROVED METHODS TO PREVENT SEDIMENT FROM ENTERING ANY STORM DRAIN, DITCH, OR WATER COURSE.

EROSION CONTROL MAP
1"=20'-0"

APPROVED FOR CONSTRUCTION
DATE: 10/12/11

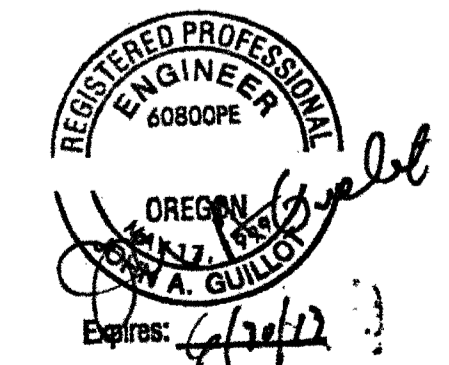

HUNT, GUILLOT & ASSOCIATES, L.L.C.
CONSULTING ENGINEERS AND PROJECT MANAGERS
P.O. BOX 580 RUSTON, LA 71273
MOEL B:

CONFIDENTIAL
THESE DESIGNS AND DRAWINGS ARE THE EXCLUSIVE PROPERTY OF:
HUNT, GUILLOT & ASSOCIATES, RUSTON, LA.
NO COPY OR REPRODUCTION MAY BE MADE WITHOUT WRITTEN APPROVAL.

ADROIT CONSTRUCTION
RVTD CNG FUELING STATION
EROSION CONTROL DETAILS

DESIGNED BY	PBW	8/23/11	CHECKED BY	CEH	9/14/11
DRAWN BY	PBW	8/23/11	APPROVED BY	RSO	9/14/11
DATE	8/23/11	HGA JOB NO:	7110004	HGA ITEM NO:	
SCALE	DRAWING NUMBER		REV.		
AS NOTED	7.110004-C-201		0		

NOTES:

1. ALL FENCE CONSTRUCTION AND COMPONENTS SHALL BE IN ACCORDANCE WITH THE "CHAIN LINK FENCE MANUFACTURERS INSTITUTE" (CLFMI) PRODUCT MANUAL.
2. ALL POST HOLES, EXCEPT GATE POST, SHALL BE AUGERED. DO NOT FORM.
3. PIPE LINES AND OTHER UNDERGROUND UTILITIES SHALL BE LOCATED BEFORE AUGERING.
4. BARBED WIRE SHALL BE INSTALLED BELOW FENCE LINE, AT EXCESSIVE OPENINGS, I.E. DRAINAGE POINTS.
5. FOR CONCRETE GENERAL NOTES, SEE DRAWING STD-F-001.

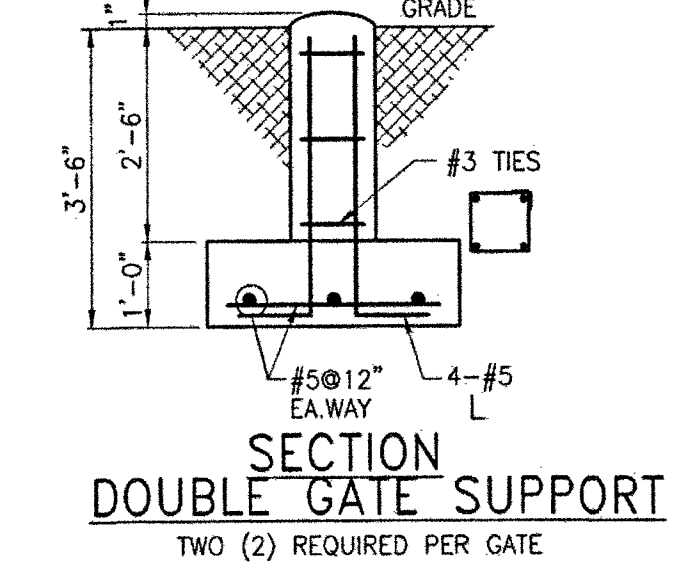
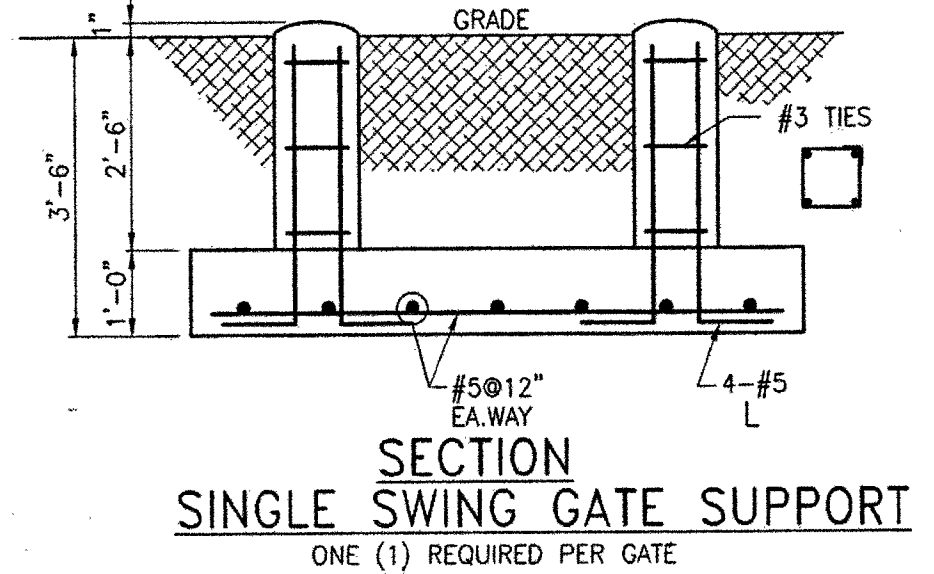
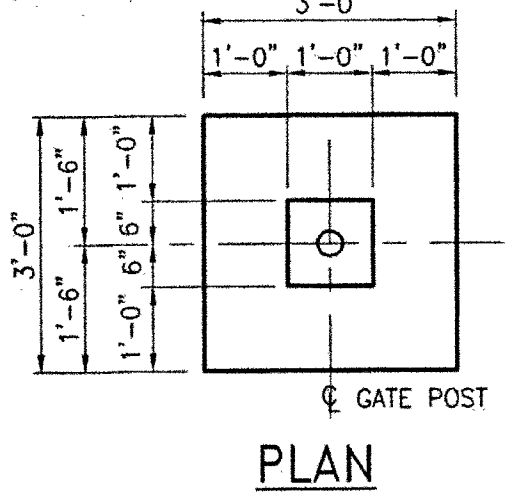
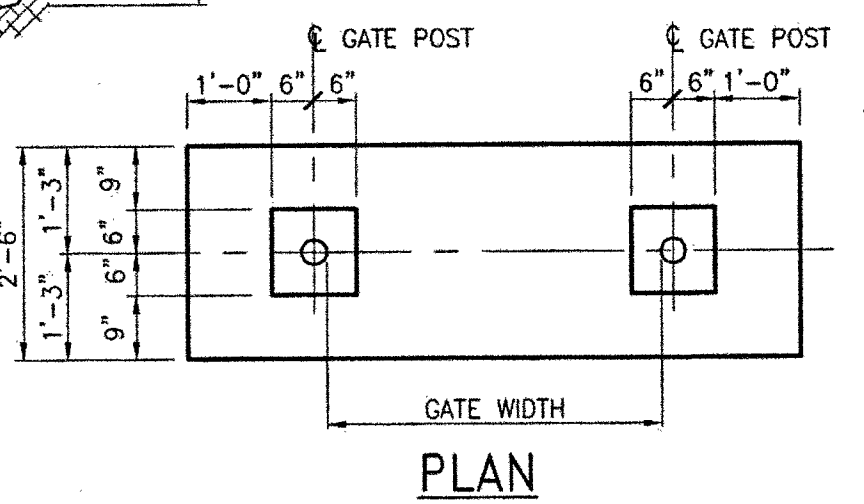
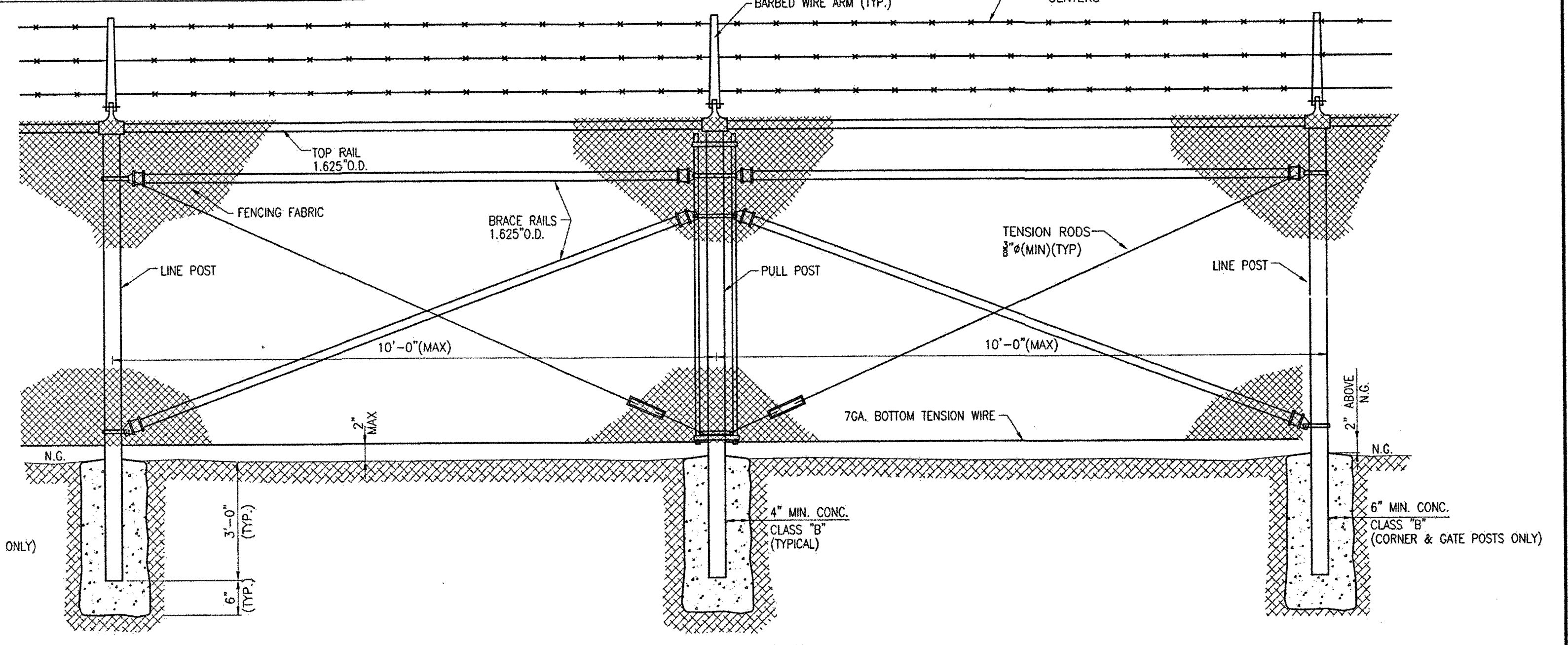
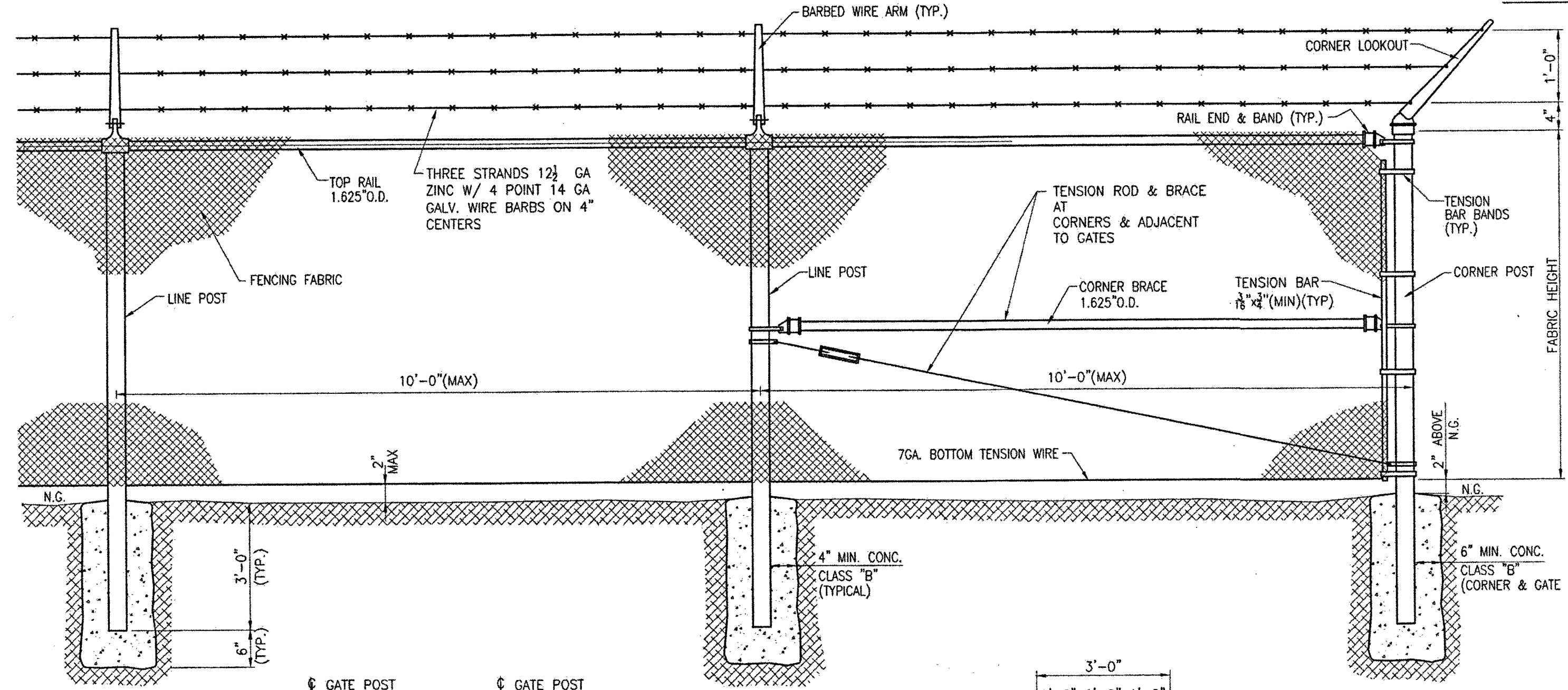
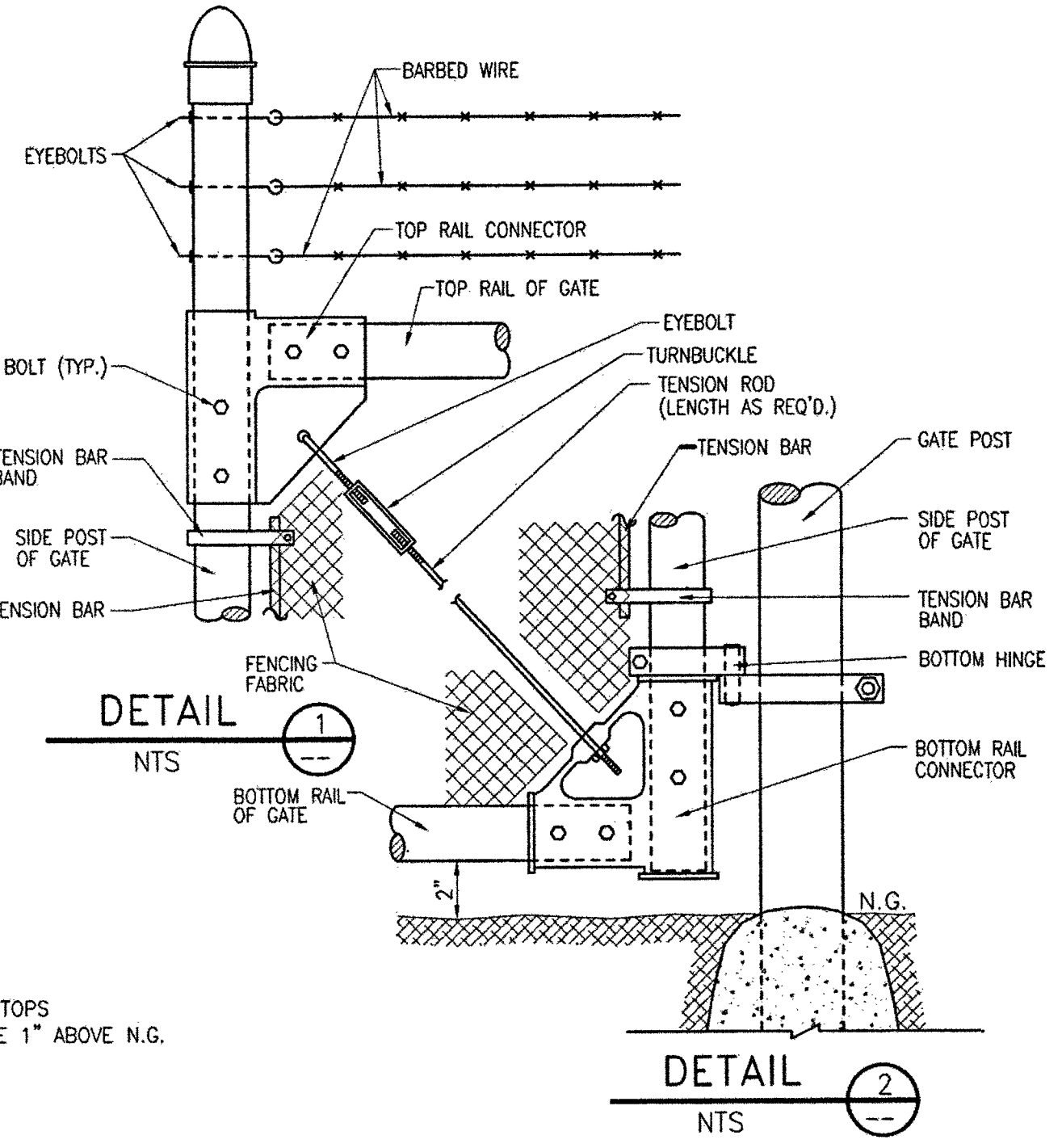
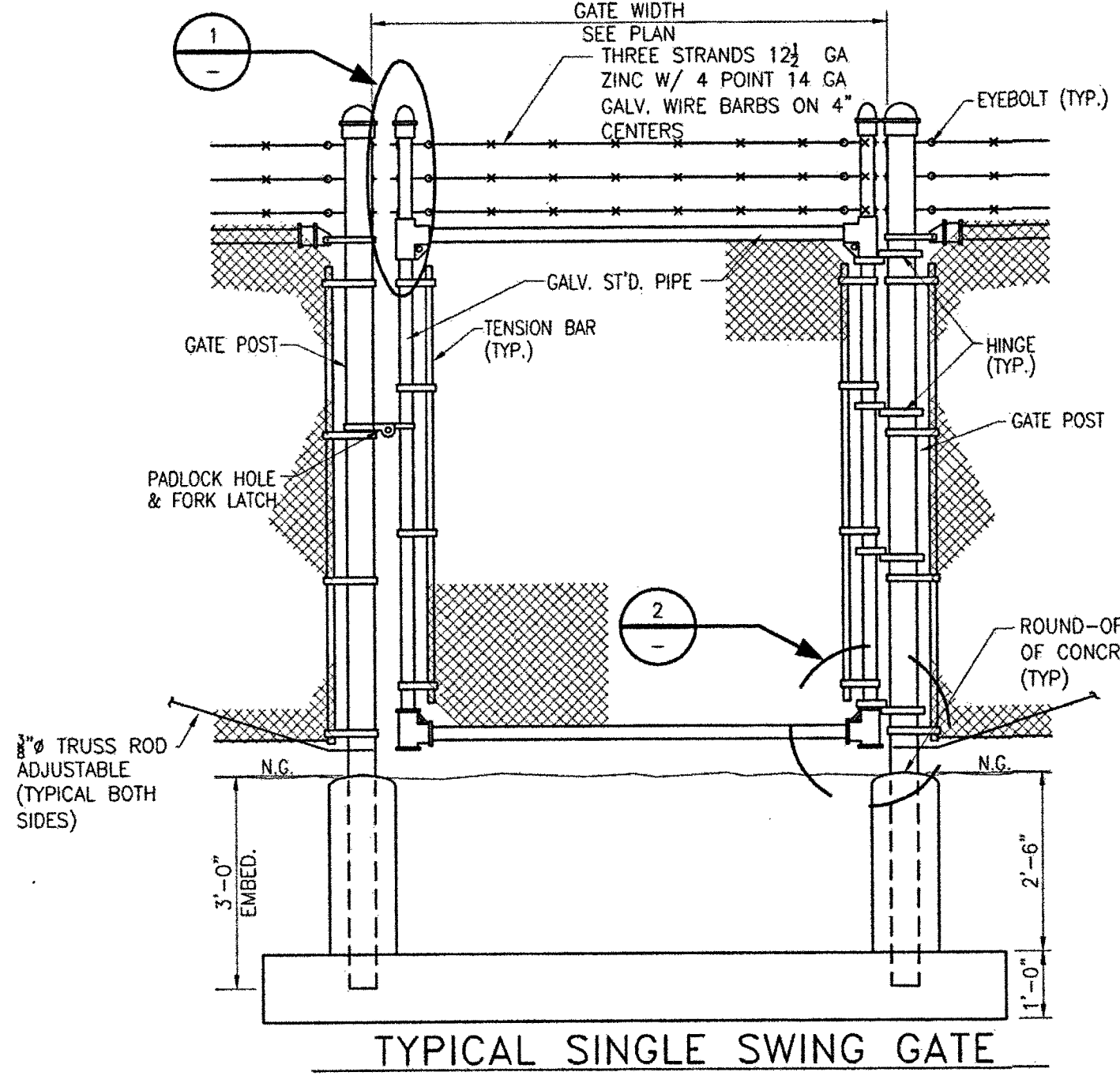
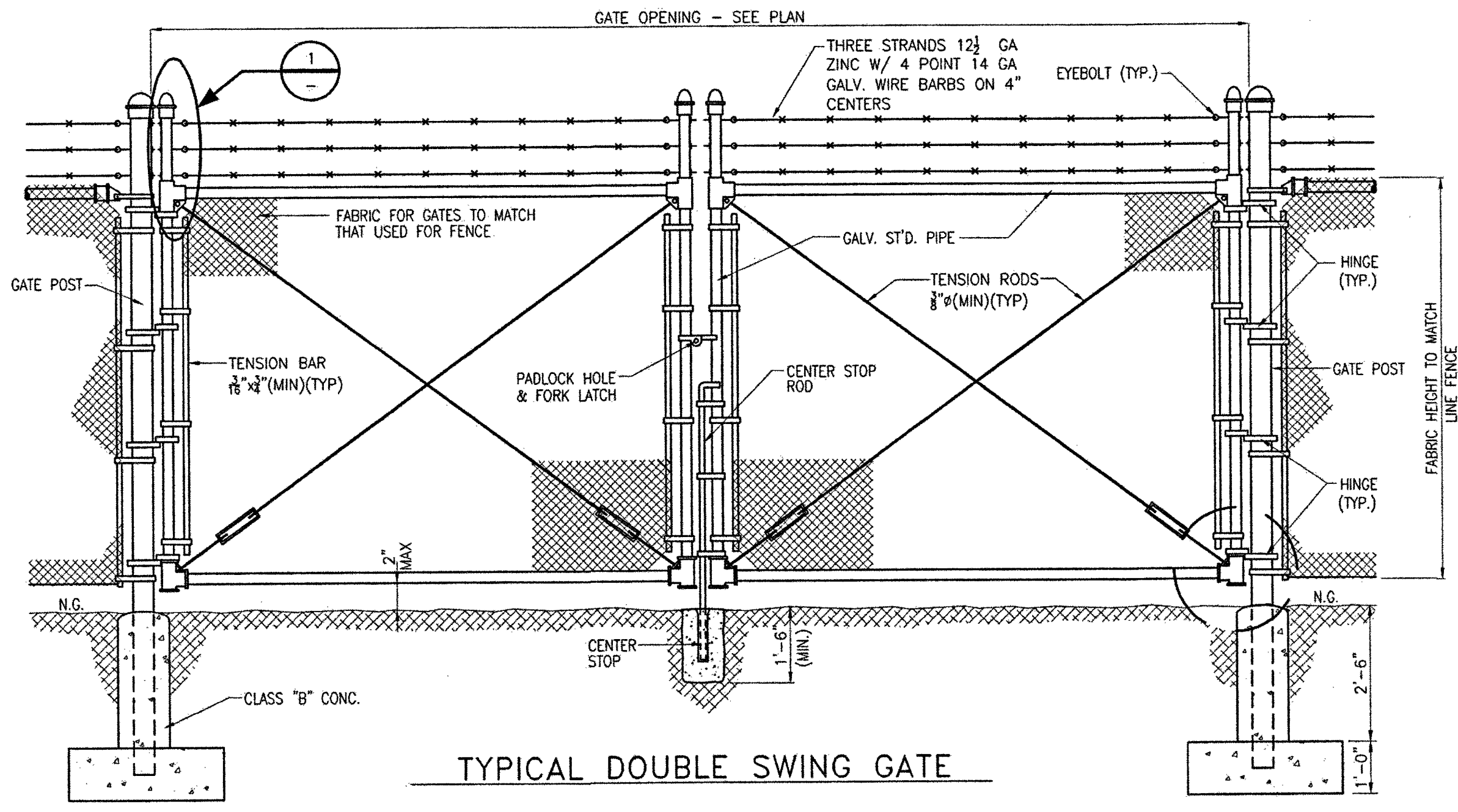
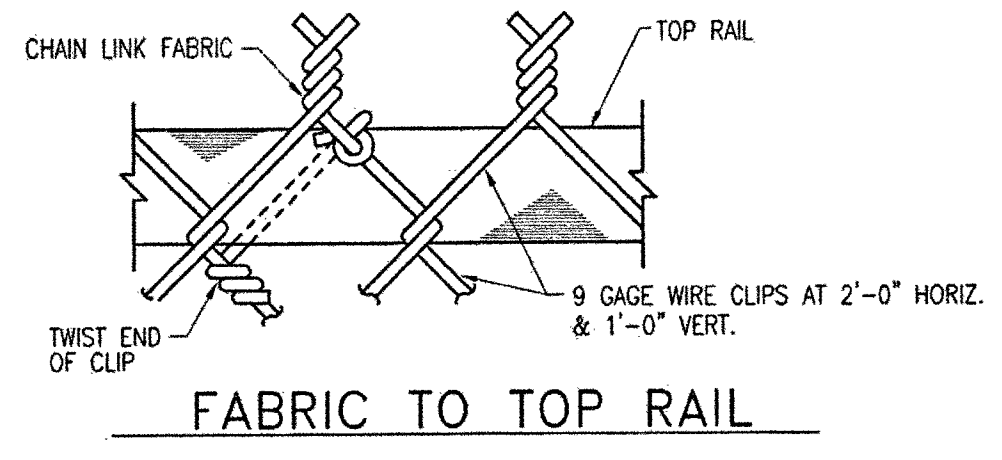
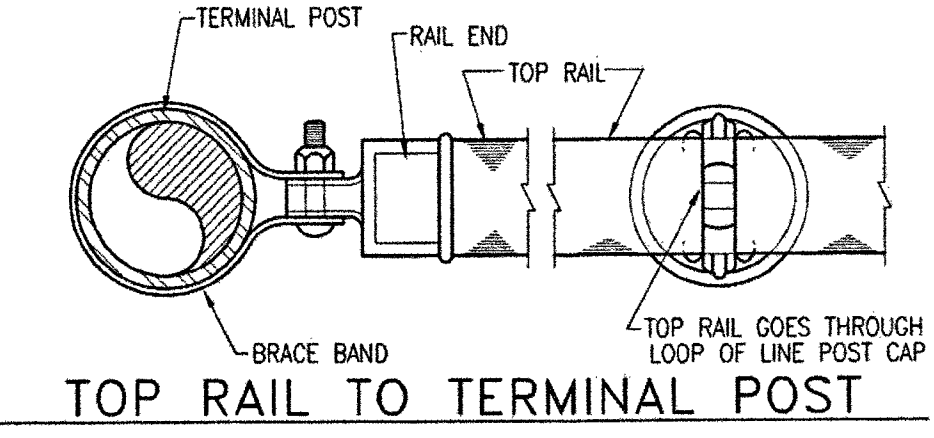
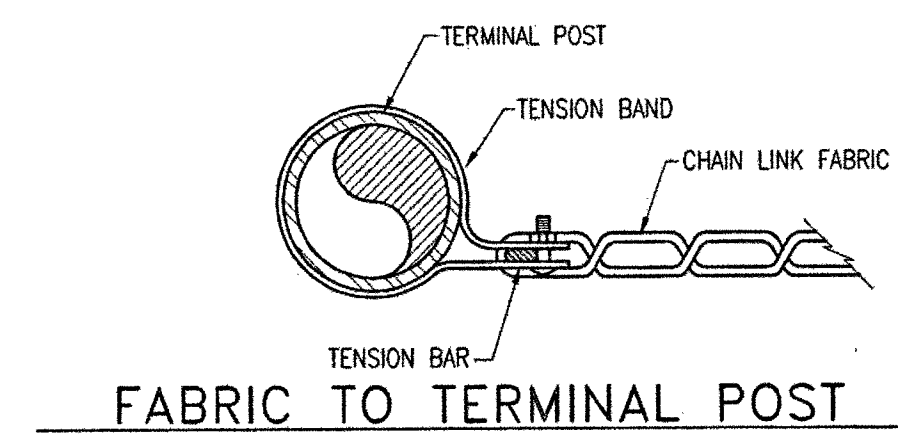

NOTE:
ALL HARDWARE TO BE GALVANIZED

FABRIC	HEAVY INDUSTRIAL	MEDIUM INDUSTRIAL	LIGHT INDUSTRIAL
SIZE	2"	2"	2"
GAGE	9	9	11

	6'-0" OR LESS	OVER 6'-0"
END, CORNER & PULL POST	2.375'00	2.875'00
LINE POST	1.90'00	2.375'00
GATE FRAME	1.66'00	1.90'00

	6'-0" OR LESS	OVER 6'-0"
GATE FRAME	1.66'00	1.90'00

GATE POST	GATE WIDTH FABRIC HEIGHT 6'-0" OR LESS
4'-0" OR LESS	2.375'00
4'-0" TO 10'-0"	2.875'00
10'-0" TO 18'-0"	4.00'00

GATE POST	GATE WIDTH FABRIC HEIGHT 6'-0" OR MORE
6'-0" TO 12'-0"	4.00'00
12'-0" TO 18'-0"	6.625'00
18'-0" TO 24'-0"	8.625'00

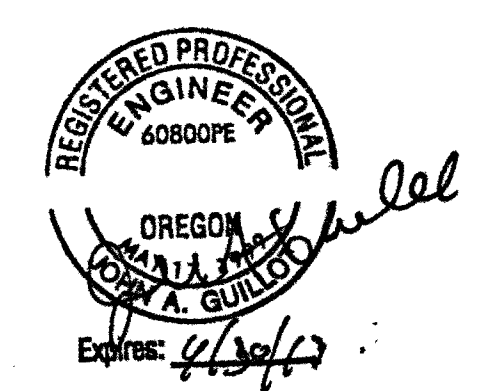

APPROVED FOR CONSTRUCTION
DATE: 10/12/11

HUNT, GUILLOT & ASSOCIATES, L.L.C.
CONSULTING ENGINEERS AND PROJECT MANAGERS
P.O. BOX 580 RUSTON, LA 71273

CONFIDENTIAL
THESE DESIGNS AND DRAWINGS ARE THE EXCLUSIVE PROPERTY OF:
HUNT, GUILLOT & ASSOCIATES, RUSTON, LA.
NO COPY OR REPRODUCTION MAY BE MADE WITHOUT WRITTEN APPROVAL.

ADROIT CONSTRUCTION
RVTD CNG FUELING STATION
FENCE DETAILS

DESIGNED BY	HGA	2009	CHECKED BY	RSO	9/14/11
DRAWN BY	ADM	2009	APPROVED BY	RSO	9/14/11
PLOT AT 1: 1	DATE: 6-4-09	HGA JOB NO: 7110004	HGA ITEM NO:		
SCALE	NONE	DRAWING NUMBER	7.110004-C-202	REV.	0
REV.	DESCRIPTION	CHK.	DATE	APP.	DATE

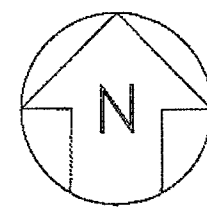
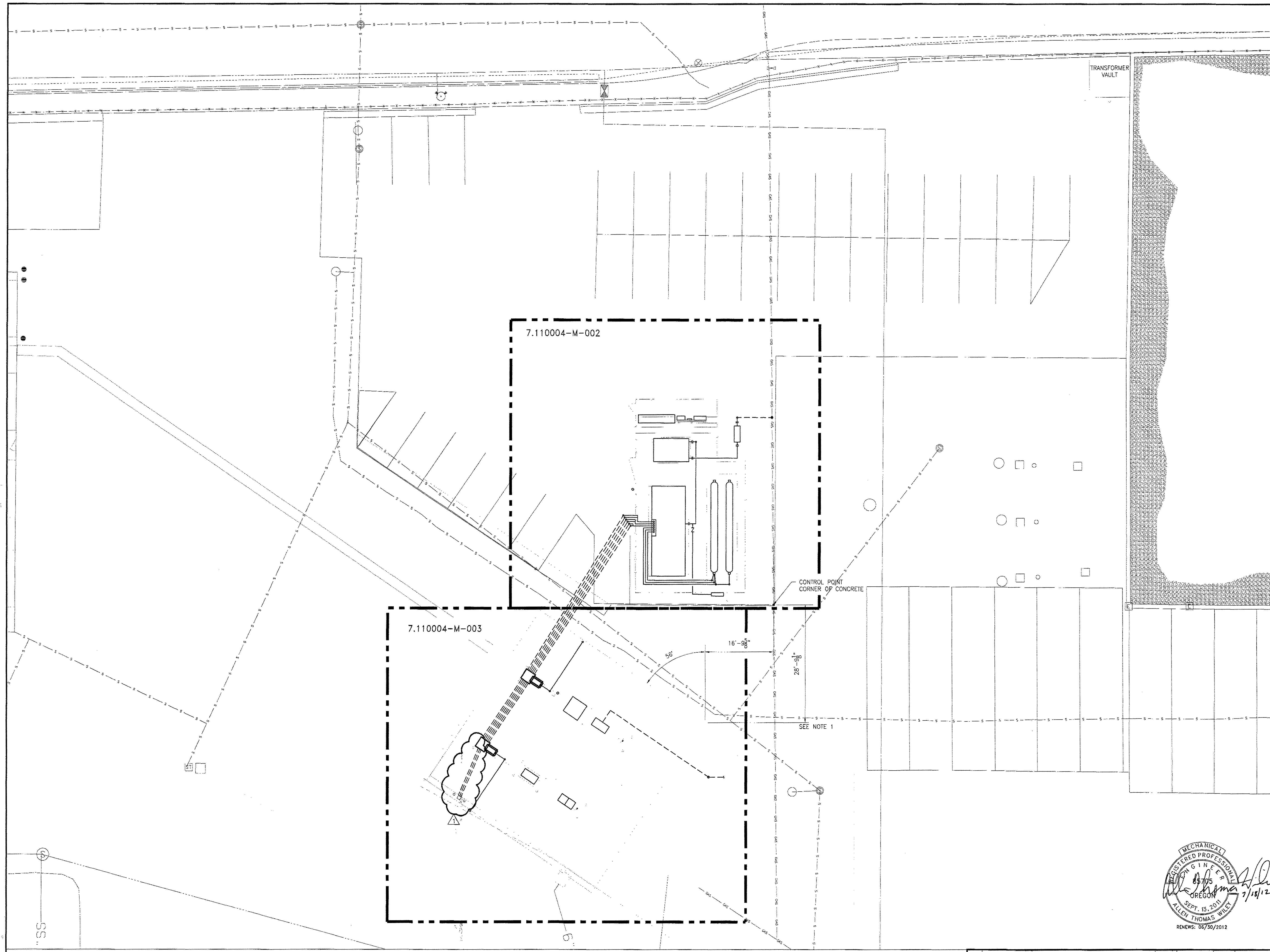

NOTES:

1. THESE DIMENSIONS ARE FOR REFERENCE ONLY, SEE DRAWING 7.11004-C-003 FOR GPS COORDINATES.

REFERENCE DRAWINGS:

- KRAUS GLOBAL:**
 HAM-3DCHG-P63C013S1S01 SHEET 1 OF 2
 HAM-3DCHG-P63C013S1S01 SHEET 2 OF 2
 DAM-3CHG-DAM-3CHG-P62C012S2S01 SHEET 1 OF 2
 DAM-3CHG-P62C012S2S01 SHEET 1 OF 2
 DAM-3CHG-P62C012S2S01 SHEET 2 OF 2
 HAM-3DCHG-P63C013S1S01
 2973.CHG-ROO SHEET 1 OF 2
 2973.CHG-ROO SHEET 2 OF 2

- KNOX WESTERN:**
 828727
 890263
 890264
 D000-3708
 D000-3281
 D000-3282 SHEET 1 OF 2
 D000-3282 SHEET 2 OF 2

- PSB:**
 NG1C1000F-G1
 NG1C1000F-P1

- HGA:**
 7.110004-M-002
 7.110004-M-003
 7.110004-M-004

APPROVED FOR CONSTRUCTION
 DATE: 7/19/12

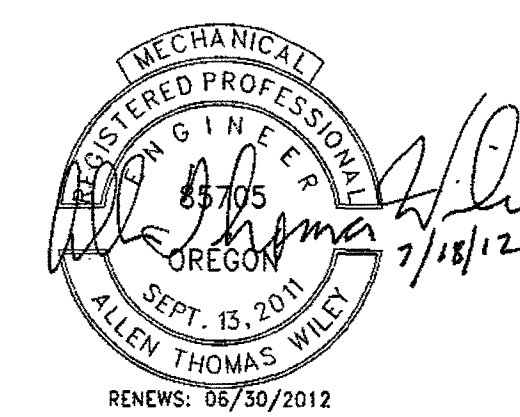

HUNT, GUILLOT & ASSOCIATES, L.L.C.
 CONSULTING ENGINEERS AND PROJECT MANAGERS
 P.O. BOX 580 RUSTON, LA 71273

MODEL ID:
 CONFIDENTIAL
 THESE DESIGNS AND DRAWINGS ARE THE EXCLUSIVE PROPERTY OF:
 HUNT, GUILLOT & ASSOCIATES, RUSTON, LA.
 NO COPY OR REPRODUCTION MAY BE MADE WITHOUT WRITTEN APPROVAL.

**ADROIT CONSTRUCTION
 Rvtd Cng Fueling Station
 SITE LAYOUT**

DESIGNED BY	AW	8/7/11	CHECKED BY	SBS	9/14/11
DRAWN BY	JRE	8/7/11	APPROVED BY	RO	9/14/11
PLOT AT 1: 1	DATE:	8/8/11	HGA JOB NO:	7.110004	HGA ITEM NO:
SCALE	DRAWING NUMBER		REV.		
3/32"=1'-0"	7.110004-M-001		1		

MEASURE MEMT

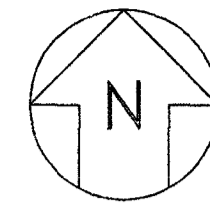

GRID LINE

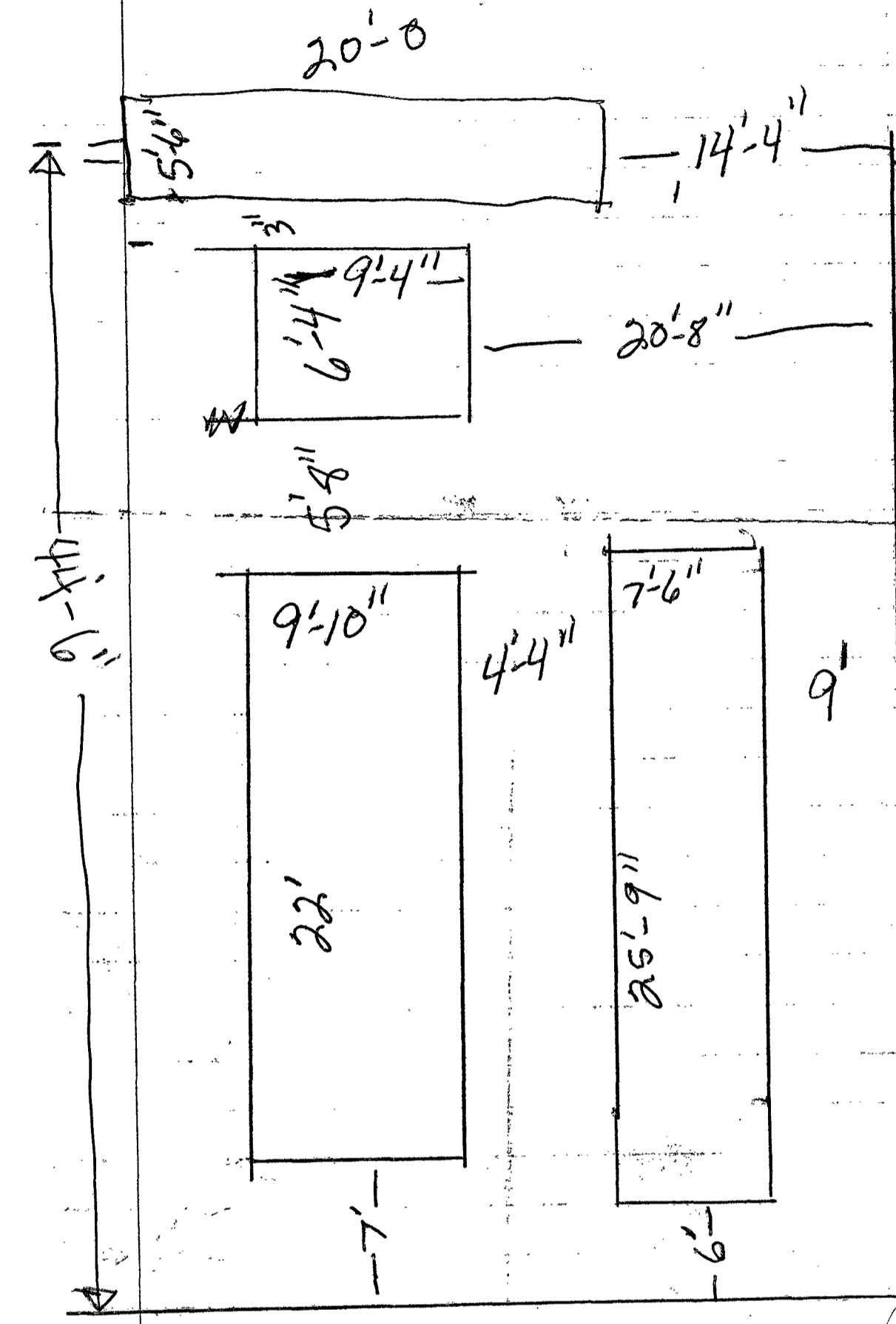
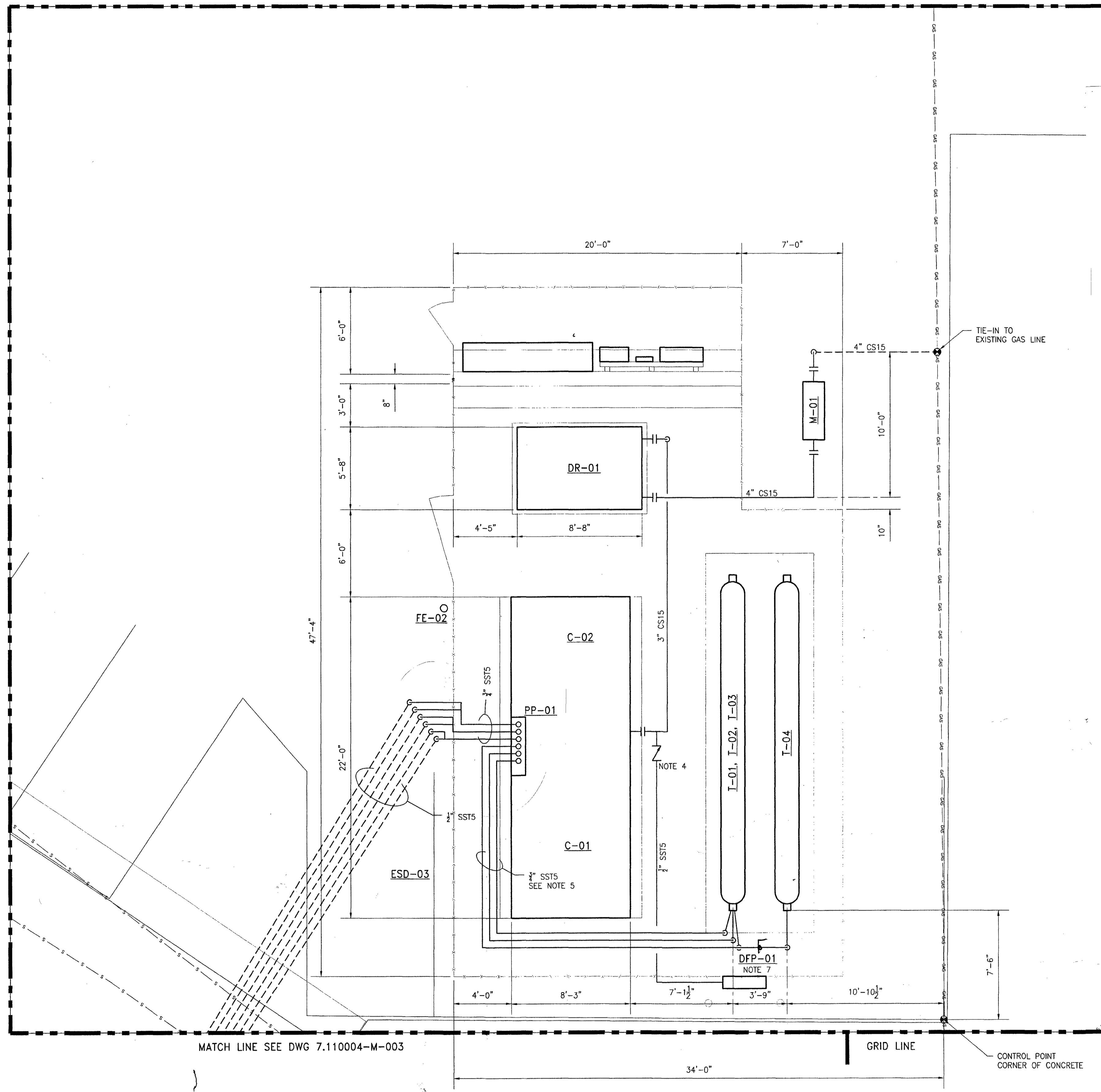

EQUIPMENT IDENTIFICATION:

EQUIP. NO.	DESCRIPTION
C-01	CNG COMPRESSOR SKID NO. 1
C-02	CNG COMPRESSOR SKID NO. 2
D-01	CNG DISPENSER NO. 1 (STANDARD)
D-02	CNG DISPENSER NO. 2 (BUS)
D-03	DIESEL DISPENSER
DFP-01	DEFUELING PANEL
DR-01	NATURAL GAS DRYER
ESD-01	EMERGENCY SHUTDOWN NO. 1 (ON DISPENSER)
ESD-02	EMERGENCY SHUTDOWN NO. 2 (ON DISPENSER)
ESD-03	EMERGENCY SHUTDOWN NO. 3
FE-01	FIRE EXTINGUISHER NO. 1 (TYPE 20 B/C)
FE-02	FIRE EXTINGUISHER NO. 2 (TYPE 20 B/C)
M-01	GAS METER
PP-01	PRIORITY PANEL
T-01	CNG STORAGE TANK NO. 1 (LOW PRESSURE)
T-02	CNG STORAGE TANK NO. 2 (MEDIUM PRESSURE)
T-03	CNG STORAGE TANK NO. 3 (HIGH PRESSURE)
T-04	CNG STORAGE TANK NO. 4 (LOW PRESSURE, EXISTING RELOCATED)

NOTES:

- PIPE LOCATIONS ARE APPROXIMATE.
- ALL UNDERGROUND PIPE SHALL BE BURIED 2'-6" MINIMUM BELOW SURFACE.
- SEE DRAWING 7.110004-M-004 FOR PIPE SPECIFICATIONS.
- CHECK VALVE PROVIDED BY CONTRACTOR.
- SUPPORT DESIGN BY INSTALLER. MAINTAIN 7'-0" CLEARANCE ABOVE FINISH FLOOR. USE SWAGELOK OR EQUAL TUBE SUPPORT SYSTEMS.
- FOR REFERENCE DRAWINGS SEE DWG. 7.110004-M-001.
- ADD 3'-0" TO POST LENGTH AND CONCRETE IN GROUND.

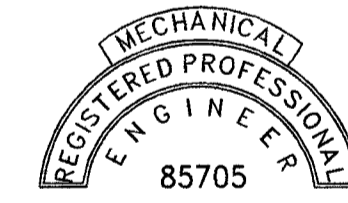

APPROVED FOR CONSTRUCTION
DATE: 10/7/11

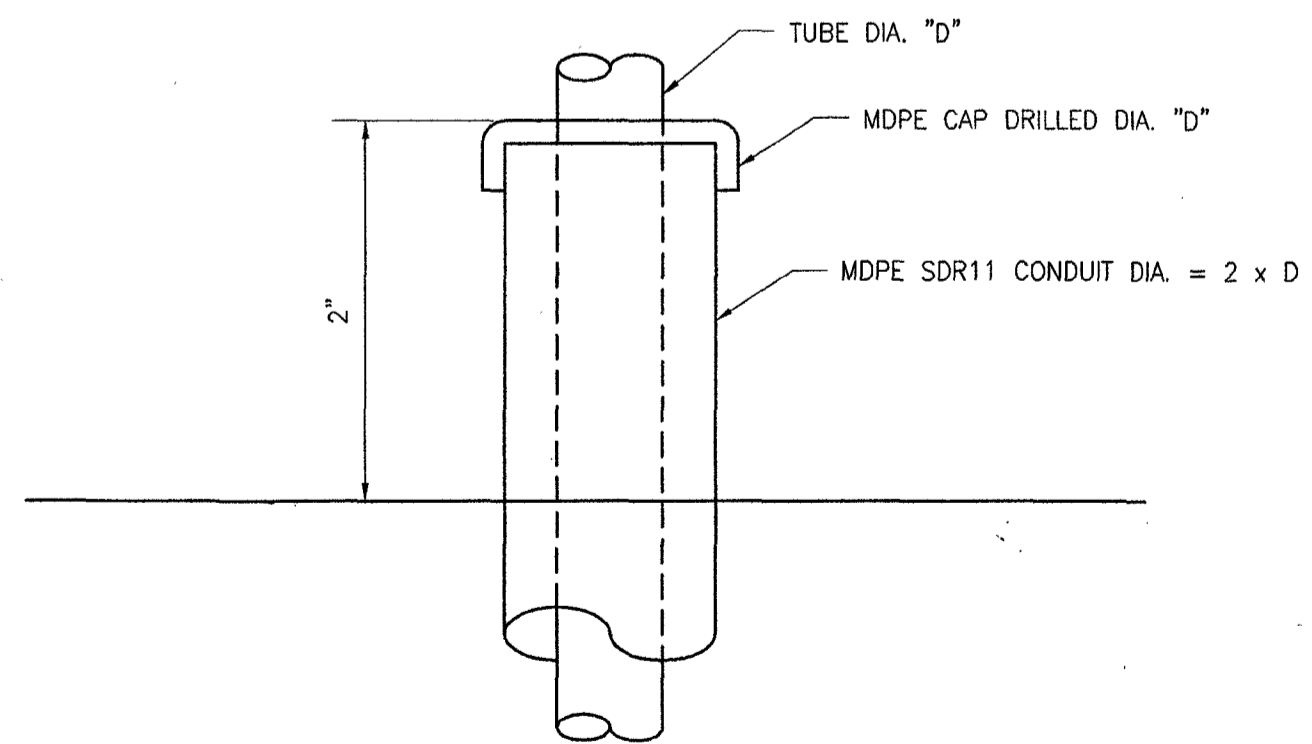

TYPICAL TUBING RISER

DETAIL

SCALE: N.T.S. M-003

HUNT, GUILLOT & ASSOCIATES, L.L.C.
CONSULTING ENGINEERS AND PROJECT MANAGERS
P.O. BOX 580 RUSTON, LA 71273

CONFIDENTIAL
THESE DESIGNS AND DRAWINGS ARE THE EXCLUSIVE PROPERTY OF:
HUNT, GUILLOT & ASSOCIATES, RUSTON, LA.
NO COPY OR REPRODUCTION MAY BE MADE WITHOUT WRITTEN APPROVAL.

ADROIT CONSTRUCTION
RVRTD CNG FUELING STATION
EQUIPMENT LAYOUT

REV.	DESCRIPTION	CHK.	DATE	APP.	DATE	SCALE	DRAWING NUMBER	REV.
0	ISSUED FOR CONSTRUCTION	SBS	10/7/11	RO	10/7/11	1/4"=1'-0"	7.110004-M-002	0

DESIGNED BY	AW	8/8/11	CHECKED BY	SBS	9/14/11
DRAWN BY	JRE	8/8/11	APPROVED BY	RO	9/14/11
PLOT AT 1: 1	DATE: 8/8/11	HGA JOB NO: 7.110004	HGA ITEM NO:		

MATCH LINE SEE DWG 7.110004-M-002

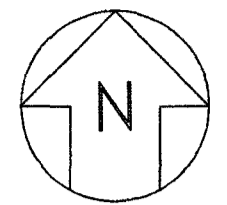

PLUMBING
AS-BUILT'S

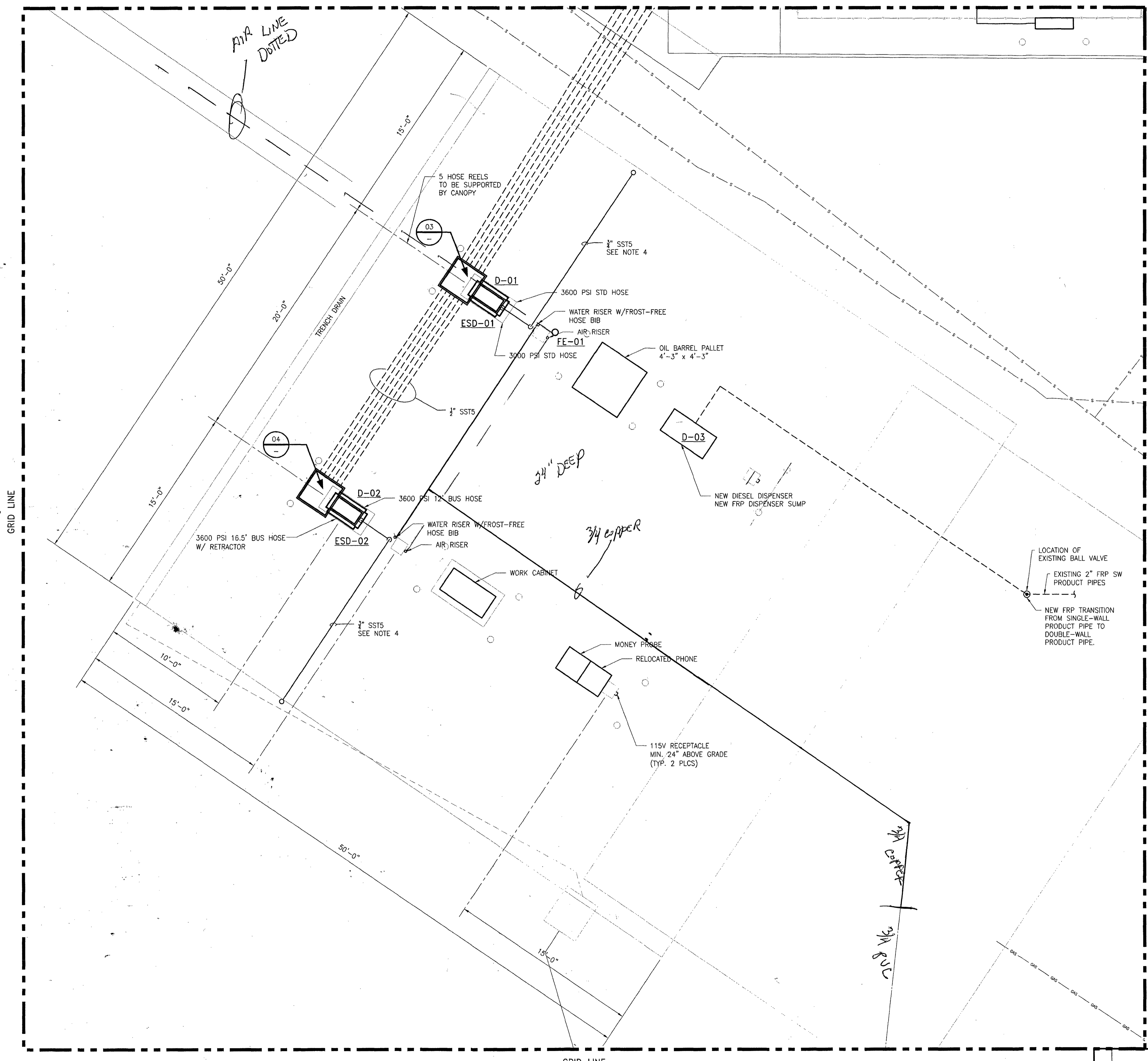

EQUIPMENT IDENTIFICATION:

EQUIP. NO.	DESCRIPTION
C-01	CNG COMPRESSOR SKID NO. 1
C-02	CNG COMPRESSOR SKID NO. 2
D-01	CNG DISPENSER NO. 1 (STANDARD)
D-02	CNG DISPENSER NO. 2 (BUS)
D-03	DIESEL DISPENSER
DFP-01	DEFUELING PANEL
DR-01	NATURAL GAS DRYER
ESD-01	EMERGENCY SHUTDOWN NO. 1 (ON DISPENSER)
ESD-02	EMERGENCY SHUTDOWN NO. 2 (ON DISPENSER)
ESD-03	EMERGENCY SHUTDOWN NO. 3
FE-01	FIRE EXTINGUISHER NO. 1 (TYPE 20 B/C)
FE-02	FIRE EXTINGUISHER NO. 2 (TYPE 20 B/C)
M-01	GAS METER
PP-01	PRIORITY PANEL
T-01	CNG STORAGE TANK NO. 1 (LOW PRESSURE)
T-02	CNG STORAGE TANK NO. 2 (MEDIUM PRESSURE)
T-03	CNG STORAGE TANK NO. 3 (HIGH PRESSURE)
T-04	CNG STORAGE TANK NO. 4 (LOW PRESSURE, EXISTING RELOCATED)

NOTES:

- PIPE LOCATIONS ARE APPROXIMATE.
- ALL UNDERGROUND PIPE SHALL BE BURIED 2'-6" MINIMUM BELOW SURFACE.
- SEE DRAWING 7.110004-M-004 FOR PIPE SPECIFICATIONS.
- RUN DISPENSER VENT LINE FROM CONNECTION AT TOP OF DISPENSER UP CANOPY COLUMN AND TERMINATE AT CANOPY EDGE. INSTALL SWAGELOK OR EQUAL VENT PROTECTOR.
- FOR REFERENCE DRAWINGS SEE DWG. 7.110004-M-001.
- CONTRACTOR TO PROVIDE 1/4-TURN BALL VALVES.

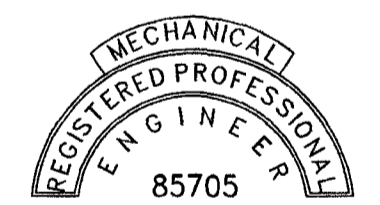
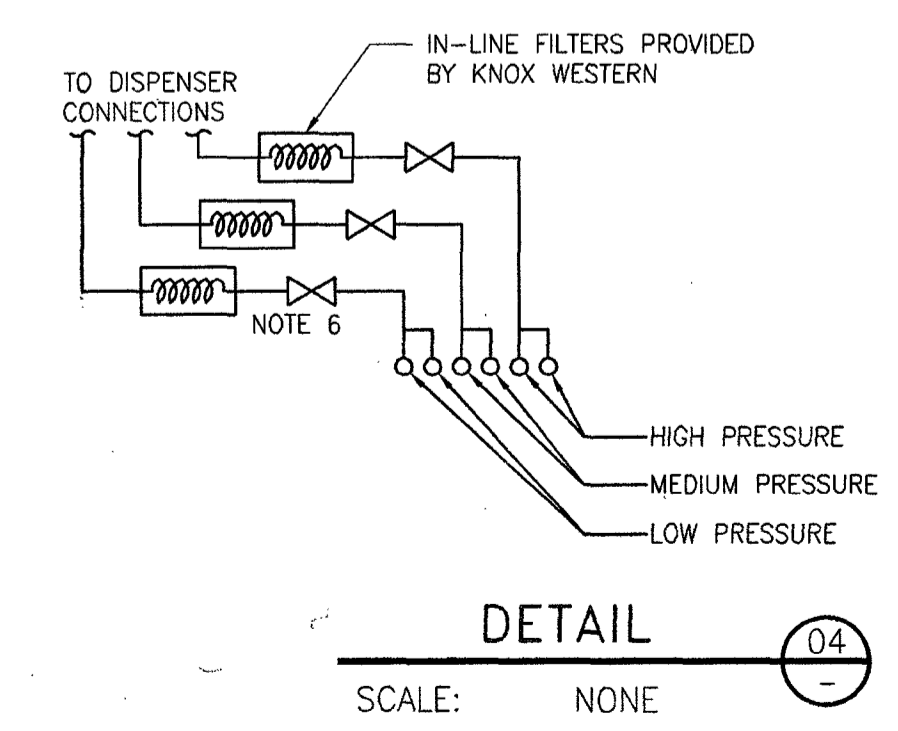
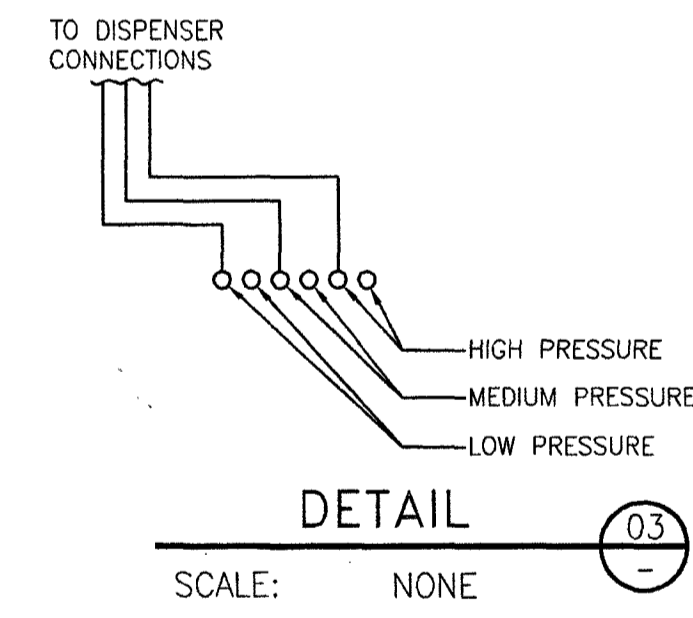

APPROVED FOR CONSTRUCTION
DATE: 10/7/11

APPROVED FOR CONSTRUCTION
DATE: 10/7/11

HUNT, GUILLOT & ASSOCIATES, L.L.C.
CONSULTING ENGINEERS AND PROJECT MANAGERS
P.O. BOX 580 RUSTON, LA 71273

CONFIDENTIAL
THESE DESIGNS AND DRAWINGS ARE THE EXCLUSIVE PROPERTY OF:
HUNT, GUILLOT & ASSOCIATES, RUSTON, LA.
NO COPY OR REPRODUCTION MAY BE MADE WITHOUT WRITTEN APPROVAL.

**ADROIT CONSTRUCTION
RVTD CNG FUELING STATION
DISPENSER LAYOUT**

REV.	DESCRIPTION	CHK.	DATE	APP.	DATE
0	ISSUED FOR CONSTRUCTION	SBS	10/7/11	RSO	10/7/11

DESIGNED BY	AW	9/8/11	CHECKED BY	SBS	9/14/11
DRAWN BY	JRE	9/8/11	APPROVED BY	RSO	9/14/11
PLOT AT 1:1	DATE: 9/8/11	HGA JOB NO: 7.110004	HGA ITEM NO:		
SCALE	1/4"=1'-0"	DRAWING NUMBER	7.110004-M-003	REV.	0

MATCH LINE SEE DWG 7.110004-M-002

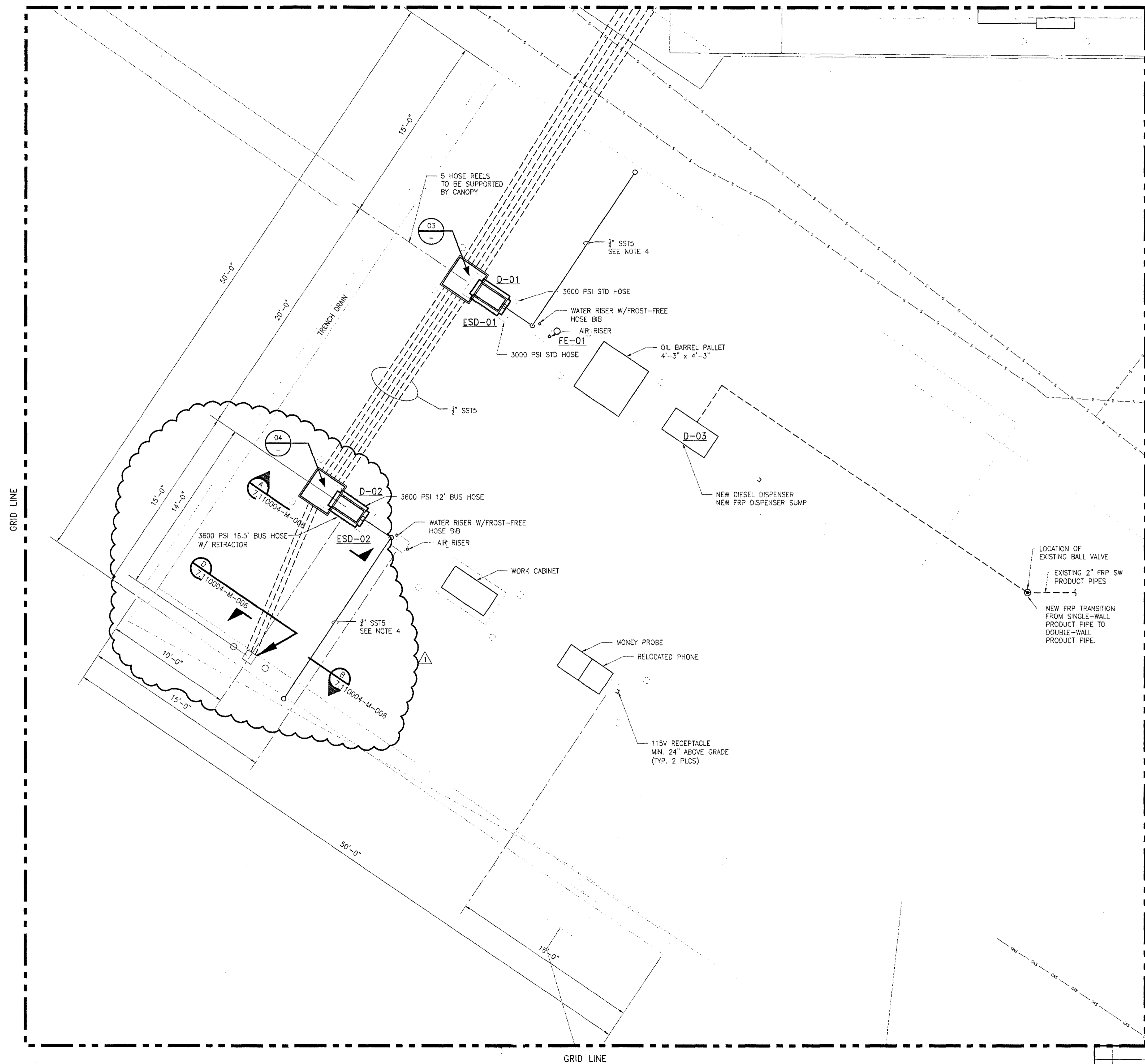
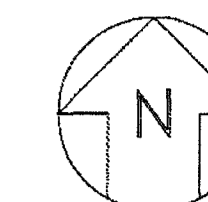

EQUIPMENT IDENTIFICATION:

EQUIP. NO.	DESCRIPTION
C-01	CNG COMPRESSOR SKID NO. 1
C-02	CNG COMPRESSOR SKID NO. 2
D-01	CNG DISPENSER NO. 1 (STANDARD)
D-02	CNG DISPENSER NO. 2 (BUS)
D-03	DIESEL DISPENSER
DPP-01	DEFUELING PANEL
DR-01	NATURAL GAS DRYER
ESD-01	EMERGENCY SHUTDOWN NO. 1 (ON DISPENSER)
ESD-02	EMERGENCY SHUTDOWN NO. 2 (ON DISPENSER)
ESD-03	EMERGENCY SHUTDOWN NO. 3
FE-01	FIRE EXTINGUISHER NO. 1 (TYPE 20 B/C)
FE-02	FIRE EXTINGUISHER NO. 2 (TYPE 20 B/C)
M-01	GAS METER
PP-01	PRIORITY PANEL
T-01	CNG STORAGE TANK NO. 1 (LOW PRESSURE)
T-02	CNG STORAGE TANK NO. 2 (MEDIUM PRESSURE)
T-03	CNG STORAGE TANK NO. 3 (HIGH PRESSURE)
T-04	CNG STORAGE TANK NO. 4 (LOW PRESSURE, EXISTING RELOCATED)

NOTES:

- PIPE LOCATIONS ARE APPROXIMATE.
- ALL UNDERGROUND PIPE SHALL BE BURIED 2'-6" MINIMUM BELOW SURFACE.
- SEE DRAWING 7.110004-M-004 FOR PIPE SPECIFICATIONS.
- RUN DISPENSER VENT LINE FROM CONNECTION AT TOP OF DISPENSER UP CANOPY COLUMN AND TERMINATE AT CANOPY EDGE. INSTALL SWAGelok OR EQUAL VENT PROTECTOR.
- FOR REFERENCE DRAWINGS SEE DWG. 7.110004-M-001.
- CONTRACTOR TO PROVIDE 1/4-TURN BALL VALVES.

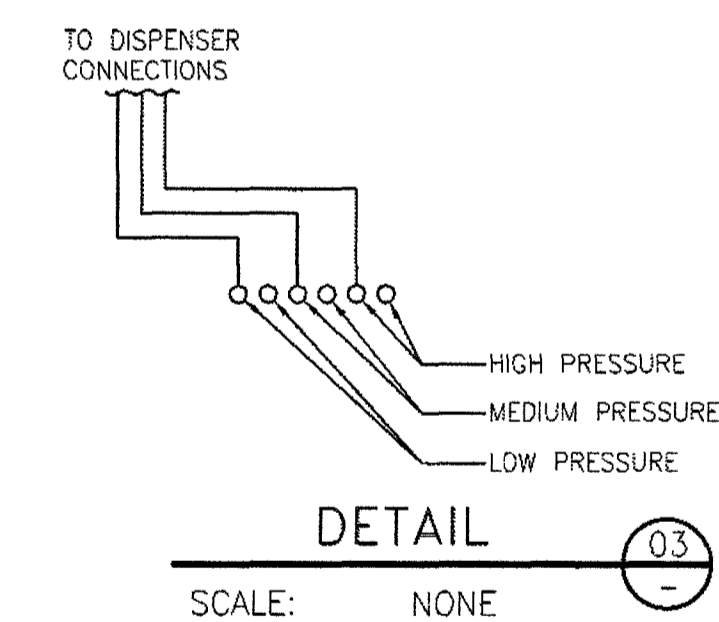

APPROVED FOR CONSTRUCTION
DATE: 7/19/12

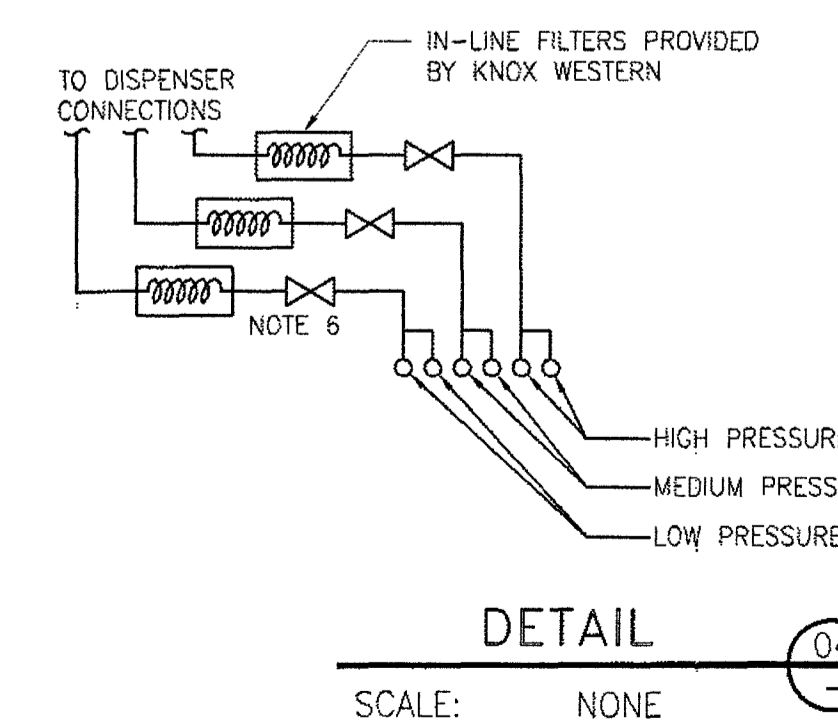

HUNT, GUILLOT & ASSOCIATES, L.L.C.
CONSULTING ENGINEERS AND PROJECT MANAGERS
P.O. BOX 580 RUSTON, LA 71273
MODEL ID:

CONFIDENTIAL
THESE DESIGNS AND DRAWINGS ARE THE EXCLUSIVE PROPERTY OF:
HUNT, GUILLOT & ASSOCIATES, RUSTON, LA.
NO COPY OR REPRODUCTION MAY BE MADE WITHOUT WRITTEN APPROVAL.

**ADROIT CONSTRUCTION
RVTD CNG FUELING STATION
DISPENSER LAYOUT**

REV.	DESCRIPTION	CHK.	DATE	APP.	DATE	SCALE	DRAWING NUMBER	REV.
1	ISSUED FOR CONSTRUCTION	SBS	7/17/12	RSD	7/19/12	1/4"=1'-0"	7.110004-M-003	1
0	ISSUED FOR CONSTRUCTION	SBS	10/7/11	RSD	10/7/11			

DESIGNED BY	AW	9/8/11	CHECKED BY	SBS	9/14/11
DRAWN BY	JRE	9/8/11	APPROVED BY	RSD	9/14/11
PLOT AT 1:1	DATE: 9/8/11	HCA JOB NO: 7.110004	HGA ITEM NO:		

APPROVED BY Chris Damiani ON Jun-14-2007

REV#	ECN#	YYYY-MM-DD	DESCRIPTION	BY
01	9265	2007-06-14	UPDATED NAME, WAS 'BPX-10R'	JW

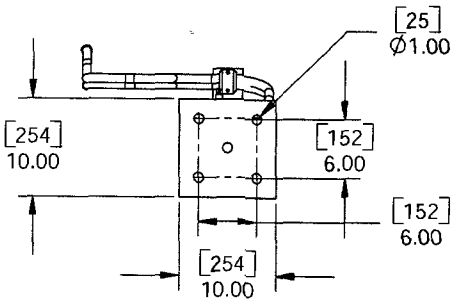
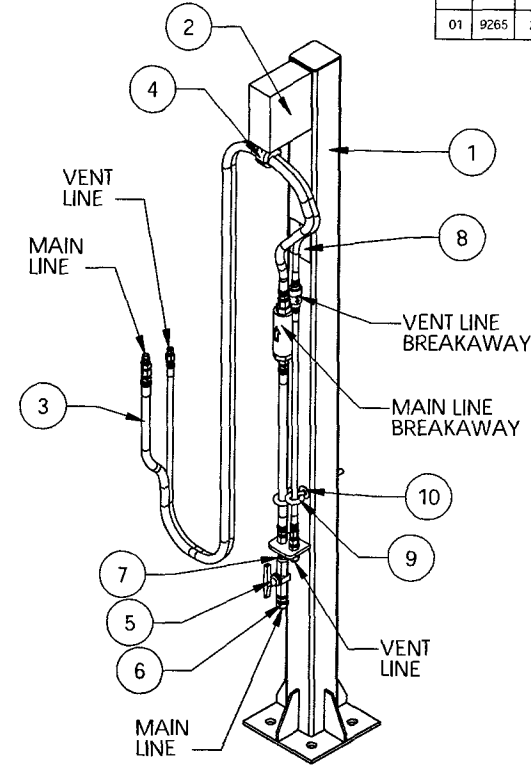
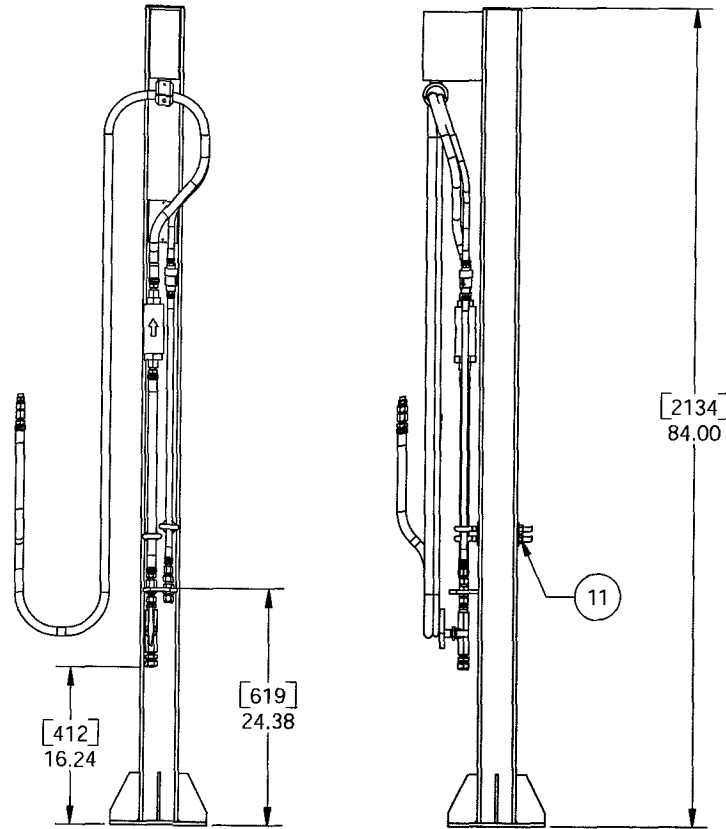

ITEM #	PART NO.	DESCRIPTION	PRESSURE	QTY	UNITS
1	25034	3099.ASY - BPX-10R Breakaway Post Welded Assembly	N/A	1	Each
2	884-034-5	884-034-5 Hose Retractors	N/A	1	Each
3	25594	3215.ASY - 1/2" Hose Assembly c/w ILB-S Breakaway (CT1000 nozzle) - Breakaway Post	See 3215.ASY	1	Each
4	24517	2991.BAR - PVC Hose Clamp - 1/2" 5000 psi Main, 1/4" 5000 psi Vent - Hose Retractor System	N/A	1	Each
5	14965	Ball Valve SS Female Ports 1/2", 2 way Parker (8F-88U2-SSP)	6000 psig (-65°F to 100°F)	1	Each
6	SS-1210-1-8	SS-1210-1-8: Male Connector 3/4" tube to 1/2" Female NPT	5800 psig (-425°F to 300°F)	1	Each
7	28798	Male Adapter (Swagelok # SS-8-1A-1-8) - 1/2" OD Tube Stub, 1/2" MNPT - SS	7700 psig (-425 F to 350 F)	1	Each
8	25080	292AY08.ART - Breakaway Post Nameplate	N/A	1	Each
9	25615	1/2" Stainless Steel Wrought Eye Bolt, 6" shank length, 1" eye ID, Spæner 024-831	N/A	2	Each
10	14343	Line - Ringed Steel	N/A	4	Each
11	20139	Nut, Hex - 1/2-13, Gr 8, Steel-YP	N/A	2	Each

MATERIAL: N/A				BREAKAWAY POST	
FINISH: N/A				BPX-20R	
TOLERANCES (L.O.S): ±0.030 GENERAL ±0.010 ON HOLE CENTERS ±1° ON ANGLES		<small>THIS DRAWING IS THE PROPERTY OF KRAUS GROUP, INC. AND IS NOT TO BE COPIED IN WHOLE OR IN PART WITHOUT WRITTEN PERMISSION. PRINTED IN CANADA ©</small>		DRAWING No. SHEET 1 OF 1	
NEXT ASSY: N/A	HOLE DIAMETERS: ±0.005	ALL DIMENSIONS IN INCHES		DRAWN BY: JWEBB	SCALE: NTS
MRP #: N/A	ASSOCIATED FLW/SCH No.: N/A	SIZE: B	DO NOT SCALE DRAWING	DESIGNED BY: C.DAMIANI	DATE: DEC 01 03
				DRAWING No. SHEET 1 OF 1	
				292AY08.CON R01	

Joe Dow

From: Meier, David [DMeier@hga-llc.com]
Sent: Wednesday, August 01, 2012 5:33 AM
To: Olsen, Richard
Cc: Wiley, Allen
Subject: FW: RVTD CNG Station -- Dispenser Revision Review

FYI

DAVID MEIER



Hunt, Guillot, & Associates, LLC
603 Reynolds Drive
Ruston, LA 71270
Office: (318) 255-6825, Ext. 447
Fax: (318) 255-8591
Mobile: (318) 243-1728
Email: dmeier@hga-llc.com

CONFIDENTIALITY NOTICE: This email transmission and its attachments may contain legally privileged and confidential information, and is intended only for the use of the individual/s or entity named above. If you are not the intended recipient, you are hereby notified that any dissemination, disclosure, distribution or copying of this email is strictly prohibited.

From: Greg Kleinberg [mailto:greg.kleinberg@cityofmedford.org]
Sent: Monday, July 30, 2012 7:00 PM
To: Meier, David
Subject: Re: RVTD CNG Station -- Dispenser Revision Review

David,

Fire approves.

Thank You,

Greg Kleinberg
Fire Marshal
Medford Fire-Rescue
541-774-2317

From: "David Meier" <DMeier@hga-llc.com>
To: "greg kleinberg" <greg.kleinberg@cityofmedford.org>
Cc: "Richard Olsen" <rolsen@hga-llc.com>
Sent: Monday, July 30, 2012 11:16:09 AM
Subject: RVTD CNG Station -- Dispenser Revision Review

Greg,

Thank you for returning my call on the RVTD CNG Station redesign for the dispensers. As discussed, the dispenser manufacturer did not have any problems with our design on a code conformity basis. Unless you have any further questions, please respond to this email with confirmation from your office that we have approval to construct the items shown in the plans submitted under HGA Transmittal No. 7.110004.00.0-017.

Thanks,

DAVID MEIER



Hunt, Guillot, & Associates, LLC

603 Reynolds Drive

Ruston, LA 71270

Office: (318) 255-6825, Ext. 447

Fax: (318) 255-8591

Mobile: (318) 243-1728

Email: dmeier@hga-llc.com

CONFIDENTIALITY NOTICE: This email transmission and its attachments may contain legally privileged and confidential information, and is intended only for the use of the individual/s or entity named above. If you are not the intended recipient, you are hereby notified that any dissemination, disclosure, distribution or copying of this email is strictly prohibited.

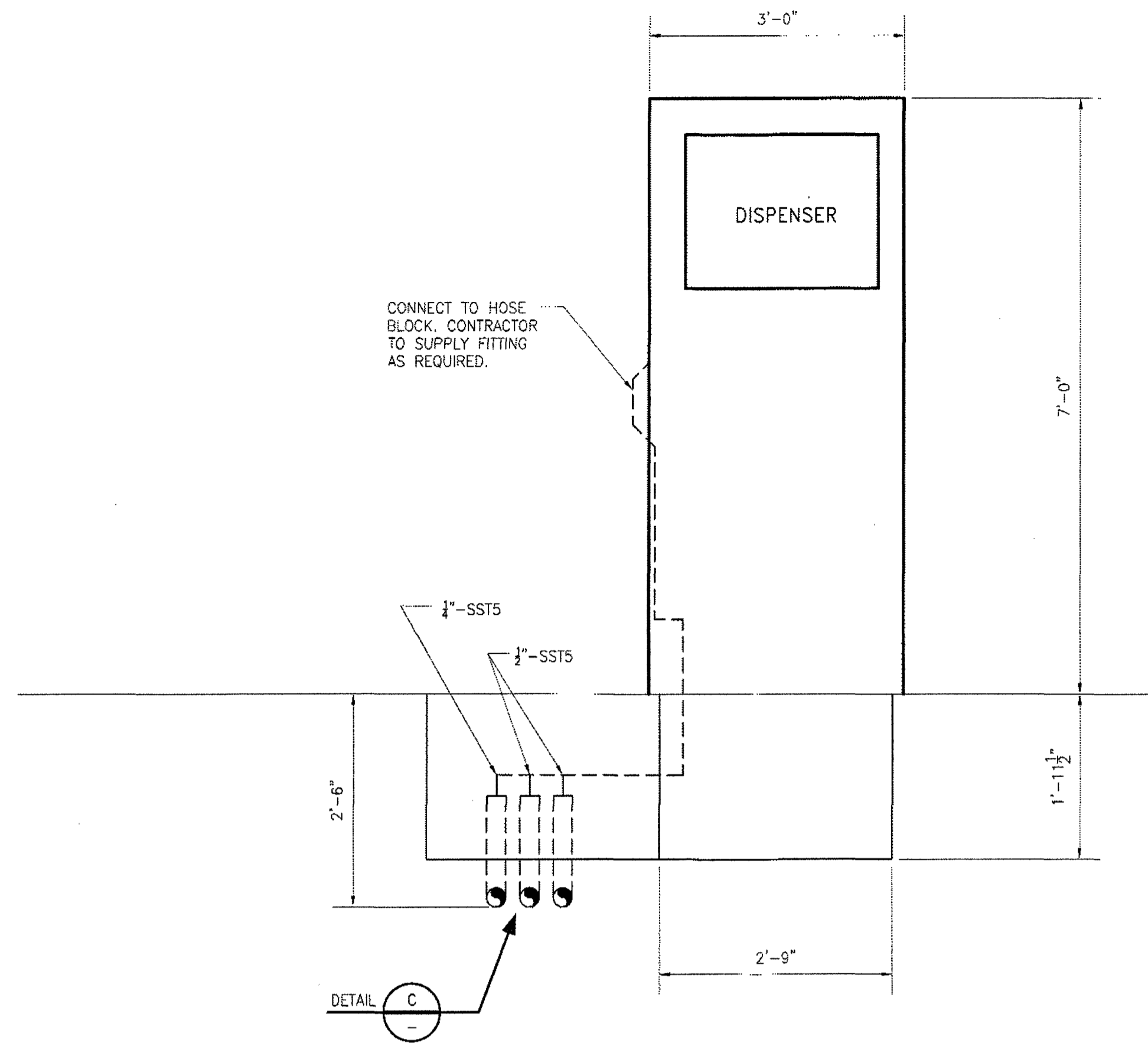

SECTION A
SCALE: 3/4"=1'-0" 7.110004-M-003

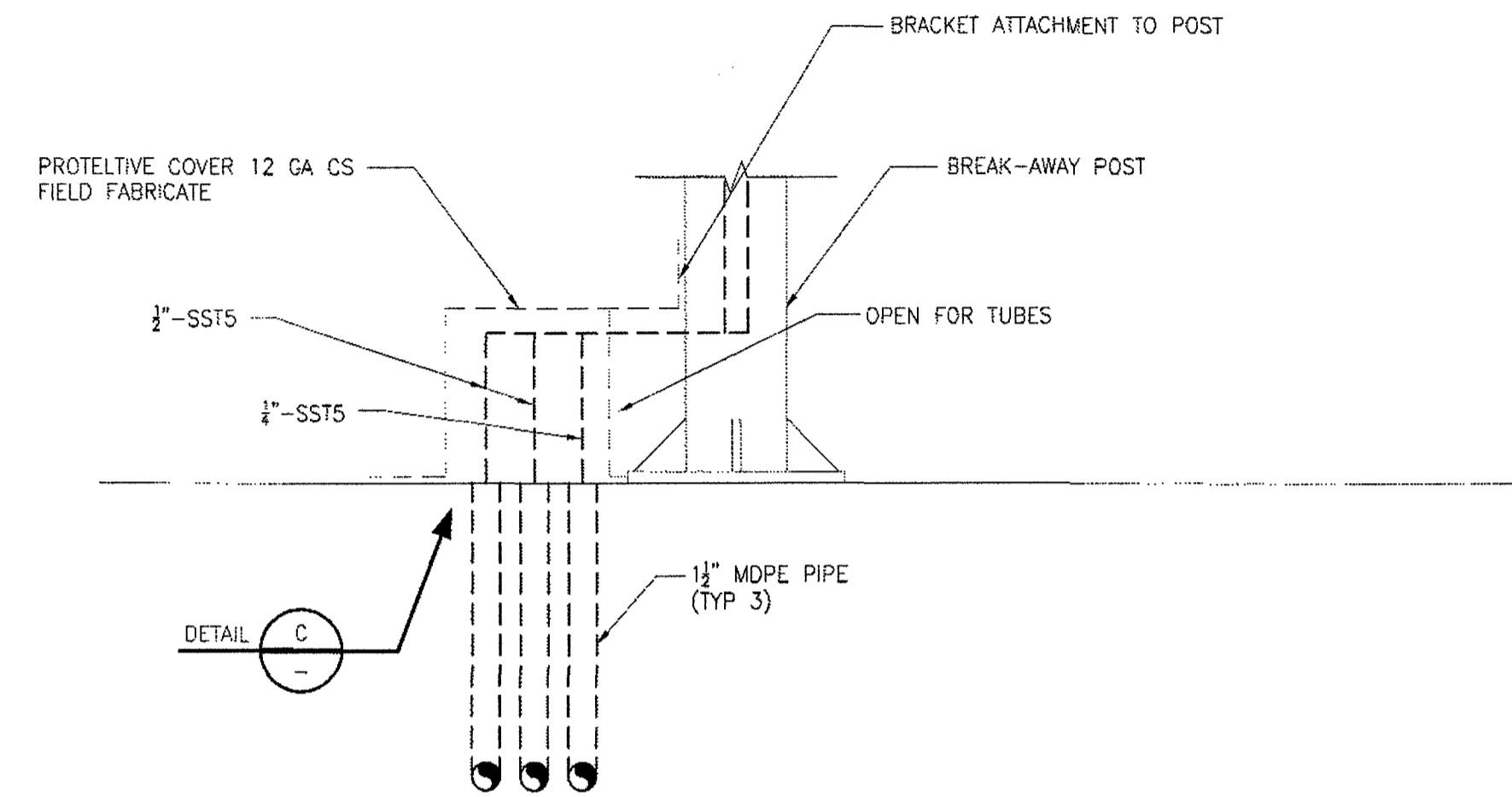

SECTION B
SCALE: 3/4"=1'-0" 7.110004-M-003

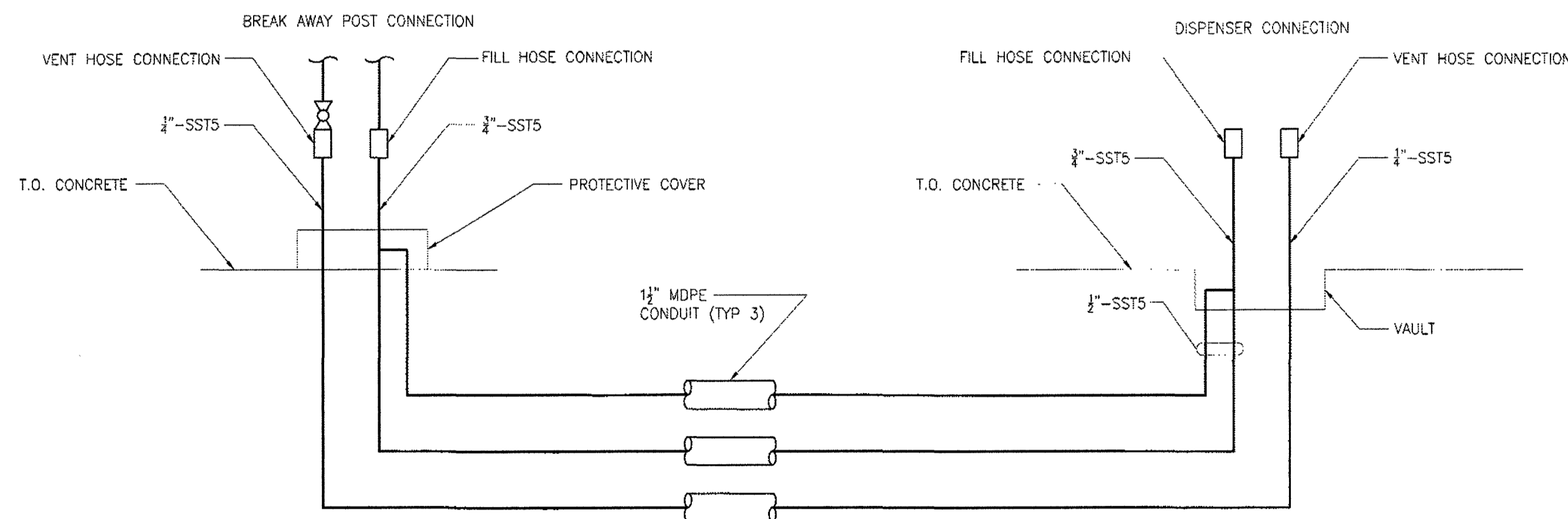

DETAIL C
SCALE: NONE
REMOTE FILL POST SCHEMATIC

NOTE:
CONTRACTOR TO SUPPLY FITTINGS
AS REQUIRED TO CONNECT TO
DISPENSER AND BREAK-AWAY
HOSE POST.

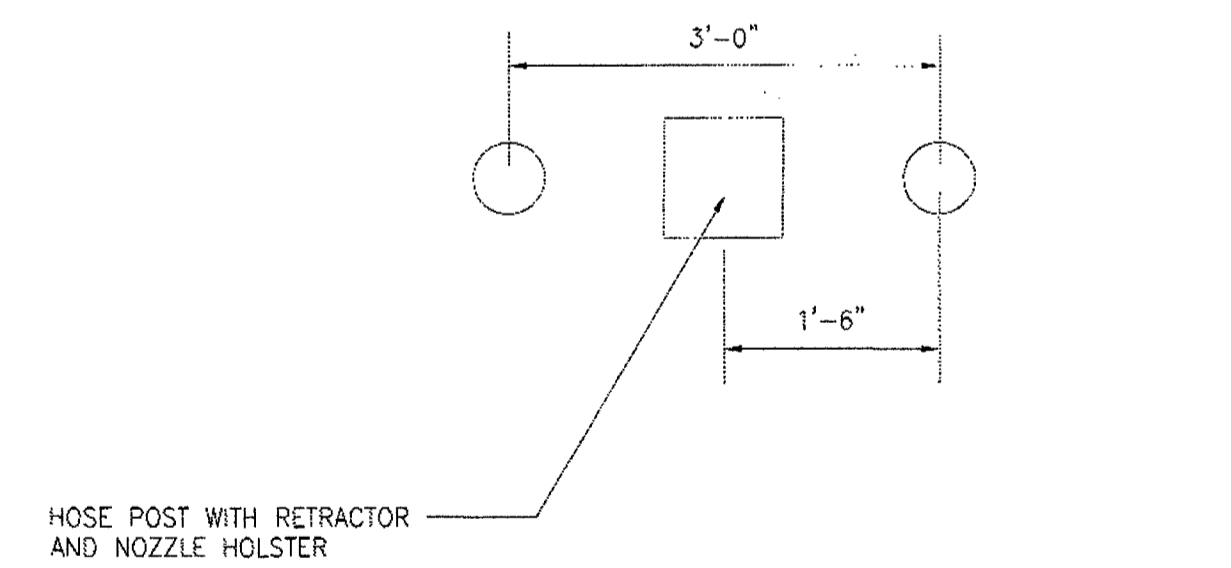

DETAIL D
SCALE: 3/4"=1'-0" 7.110004-M-003

APPROVED FOR
CONSTRUCTION
DATE: 7/19/12



HUNT, GUILLOT & ASSOCIATES, L.L.C.
CONSULTING ENGINEERS AND PROJECT MANAGERS
P.O. BOX 580 RUSTON, LA 71273
MODEL ID:

CONFIDENTIAL
THESE DESIGNS AND DRAWINGS ARE THE EXCLUSIVE PROPERTY OF:
HUNT, GUILLOT & ASSOCIATES, RUSTON, LA.
NO COPY OR REPRODUCTION MAY BE MADE WITHOUT WRITTEN APPROVAL.

ADROIT CONSTRUCTION
RVTD CNG FUELING STATION
SECTIONS AND DETAILS

DESIGNED BY	AW	7/16/12	CHECKED BY	SBS	7/17/12
DRAWN BY	JRE	7/16/12	APPROVED BY	RSO	7/19/12
PLOT AT 1:	1	DATE: 7/16/12	HGA JOB NO: 7.110004	HGA ITEM NO:	
SCALE	DRAWING NUMBER		REV.		
AS NOTED	7.110004-M-006		0		

SYMBOL SCHEDULE	
SYMBOL	DESCRIPTION
□	SURFACE MOUNTED DROPPED PRISMATIC CANOPY LIGHTING FIXTURE.
□	NON-FUSED DISCONNECT SWITCH RATED 30 AMPS UNLESS NOTED OTHERWISE. SWITCH MUST BE PAD LOCKABLE IN OPEN POSITION.
□	FUSED DISCONNECT SWITCH RATED 30 AMPS UNLESS NOTED OTHERWISE. SWITCH MUST BE PAD LOCKABLE IN OPEN POSITION.
⊕	DUPLEX RECEPTACLE MOUNTED AT 24" AFF UNLESS INDICATED OTHERWISE. REFER TO SPECIFICATIONS.
⊕ GFCI	DUPLEX RECEPTACLE WITH INTEGRAL PERSONNEL GROUND FAULT CIRCUIT INTERRUPTER (GFCI). REFER TO SPECIFICATIONS.
⊕ WP	WEATHERPROOF DUPLEX RECEPTACLE
●	JUNCTION BOX, CEILING MOUNTED AS INDICATED ON DRAWINGS.
○	WALL MOUNTED JUNCTION BOX.
⊕	SEAL FITTING FOR HAZARDOUS ELECTRICAL INSTALLATIONS. REFER TO NEC ARTICLE 514, PARAGRAPHS 514-6 AND 514-8 FOR SEAL INSTALLATION INFORMATION.
⊕	COMPRESSED NATURAL GAS DETECTOR.
⊕	COMPRESSED NATURAL GAS DETECTION AUDIO / VISUAL DEVICE.
⊕	ELECTRIC MOTOR.
⊕	COMBINATION MAGNETIC MOTOR STARTER FURNISHED AND INSTALLED BY E.C. SWITCH MUST BE PAD LOCKABLE IN OPEN POSITION.
⊕	480V, THREE PHASE, 3-WIRE DISTRIBUTION PANELBOARD.
⊕	120/208V, THREE PHASE, 4-WIRE MISCELLANEOUS LIGHTING AND POWER PANELBOARD.
⊕	277/480V, THREE PHASE, 4-WIRE LIGHTING AND POWER PANELBOARD.
⊕	CONCEALED OR EXPOSED CONDUIT RUN IN CEILING OR WALL. SLANTED LINES DENOTES NUMBER OF CONDUCTORS WHEN MORE THAN TWO. REFER TO SPECIFICATIONS.
⊕	HOMERUN TO PANELBOARD. ARROWHEADS DENOTE NUMBER OF BRANCH CIRCUITS IN CONDUIT.
⊕	CONDUIT CONCEALED IN CONCRETE SLAB OR IN EARTH. REFER TO SPECIFICATIONS.
⊕	CONDUIT WITH HOT WIRE, SWITCHED LEG, NEUTRAL AND GREEN EQUIPMENT GROUND (LEFT-TO-RIGHT)
⊕	UNDERGROUND PRIMARY RADIAL FEEDER. COMPLY WITH LOCAL UTILITY CRITERIA
AFF	ABOVE FINISHED FLOOR.
AFC	ABOVE FINISHED CEILING
AFG	ABOVE FINISHED GRADE
WP	WEATHERPROOF
EC	ELECTRICAL CONTRACTOR.
GC	GENERAL CONTRACTOR.
EL	EMERGENCY LIGHT.
NTS	NOT TO SCALE
GFCI	GROUND FAULT CIRCUIT INTERRUPTER FOR PERSONNEL PROTECTION.
NIC	NOT IN CONTRACT
ETR	EXISTING TO REMAIN
TBR	TO BE REMOVED
⊕	GROUND CONNECTION.
⊕	MOLDED CASE CIRCUIT BREAKER. REFER TO SPECIFICATIONS.
⊕	AVAILABLE FAULT CURRENT AT THE INDICATED LOCATION.
---	DENOTES FIELD WIRING TO BE INSTALLED BY E.C.

LIGHTING FIXTURE SCHEDULE				LAMP SCHEDULE		
TYPE	NOTES	MANUFACTURER & CATALOG NUMBER	BASIC AREA OF USE	TYPE	NO./WATTS	BASE
A	1,2,3,4,5	LITHONIA #KACMLED-1-63B530/50K-SR5-MVOLT-DWHXD	DISPENSER CANOPY	LED	1-180	-
-	-	-	-	-	-	-
-	-	-	-	-	-	-

- LIGHTING FIXTURE SCHEDULE NOTES:**
- OPERATING VOLTAGE IS 120 VOLT.
 - FIXTURE SHALL BE EQUIPPED WITH -20 DEGREE BALLAST.
 - FIXTURES SHALL BE U.L. LISTED FOR WET LOCATIONS.
 - REFER TO PLANS FOR MOUNTING HEIGHTS.
 - PROVIDE FIXTURE WITH INTEGRAL FROM FACTORY 120 VOLT PHOTOELECTRIC CELL.

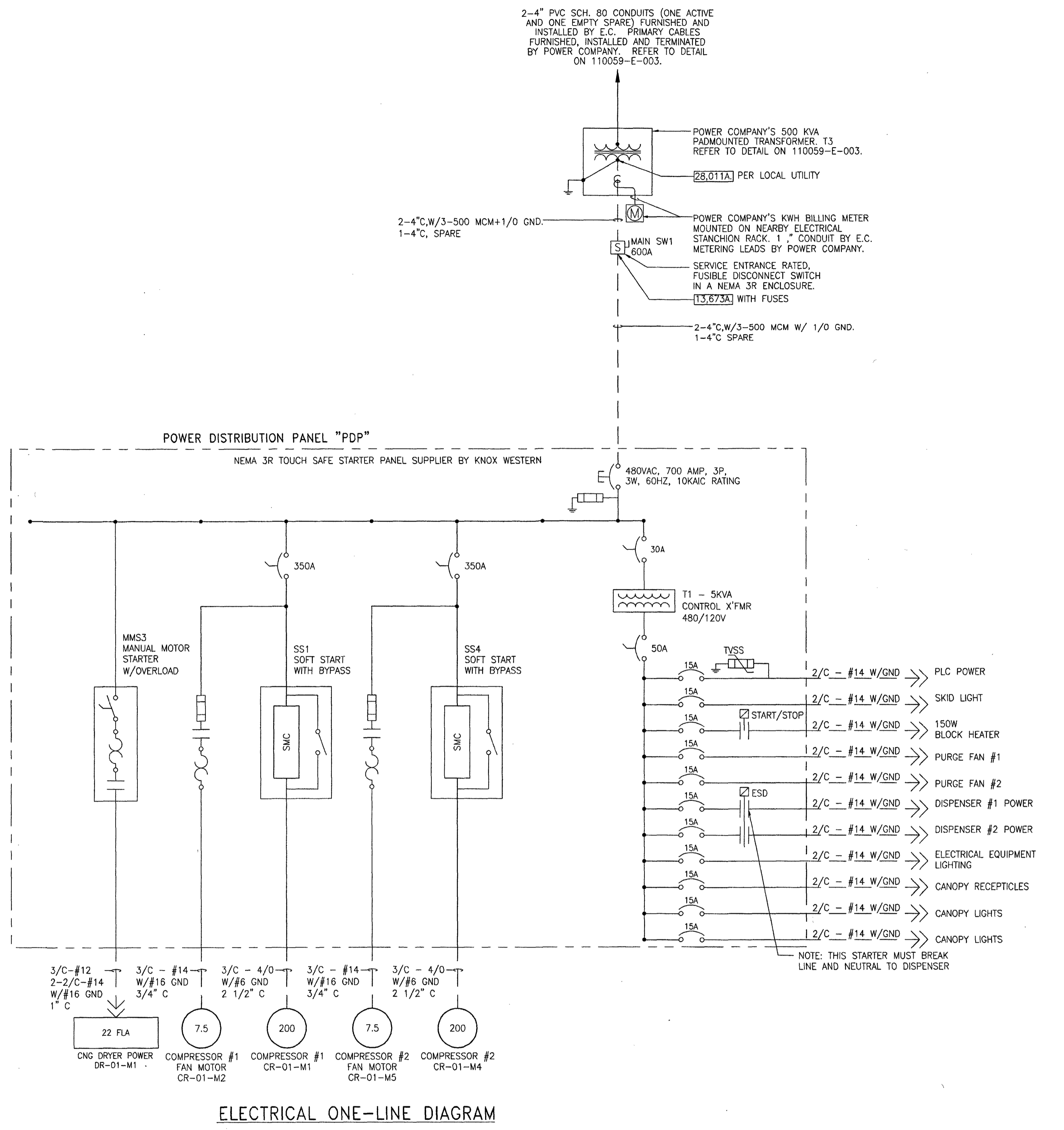

ELECTRICAL ONE-LINE DIAGRAM

- NOTES:**
- ALL CONDUCTORS ARE COPPER WITH TYPE "THWN/THHN" INSULATION.
 - ALL CIRCUIT BREAKERS SHALL BE BOLT-ON TYPE.
 - ALL TRANSFORMERS ARE NON-VENTILATED DRY TYPE, 480V, 1-PHASE PRIMARIES AND 120/240V, 1-PHASE, 3 WIRE SECONDARIES
 - ALL DISCONNECT SWITCHES ARE 3-POLE, HEAVY DUTY NEMA 3R.
 - ELECTRICAL CONTRACTOR SHALL VERIFY AND INSTALL PROPER SIZE OF ALL MOTOR OVERLOAD HEATER ELEMENTS.
 - SERVICE ENTRANCE CONDUITS, INCLUDING ALL ELBOWS, LEAVING THE UTILITY PADMOUNTED TRANSFORMER SHALL BE PVC SCH 80.
 - ALL CONNECTIONS TO GROUND RODS, COLUMN STEEL AND STANCHIONS SHALL BE MADE WITH AN EXOTHERMIC METHOD.
 - ALL LUGS IN ELECTRICAL EQUIPMENT SHALL BE RATED TO ACCEPT 75°C CONDUCTORS.
 - ADD GROUND CONDUCTOR IN EACH CONDUIT BETWEEN TRANSFORMER AND MAIN DIST. PANEL ONLY IF REQUIRED BY POWER COMPANY OR LOCAL ELECTRICAL INSPECTOR.
 - ALL ELECTRICAL EQUIPMENT ON THIS DRAWING SHALL BE NEW BY THE ELECTRICAL CONTRACTOR UNLESS NOTED OTHERWISE.
 - ALL EXPOSED CONDUIT INSTALLED MUST BE HEAVY WALL RIGID GALVANIZED STEEL UNLESS SPECIFICALLY NOTED OTHERWISE.
 - REFER TO ANGI VENDOR DRAWINGS FOR ADDITIONAL NOTES.
 - ENTIRE ELECTRICAL INSTALLATION SHALL BE IN STRICT ACCORDANCE WITH ALL NATIONAL, STATE AND LOCAL CODES.
 - ALL CONDUIT SHALL BE 1" MINIMUM GRC UNLESS NOTED OTHERWISE.
 - ALL NEW CONDUCTORS ARE #12 AWG MINIMUM WITH THWN/THHN INSULATION UNLESS NOTED OTHERWISE.

- REFERENCE DRAWINGS:**
- PROBE AUTOMATION:
AIG-XXXXX SHEETS 2 THRU 10
- HGA:
7.110004-E-002 ADROIT CONSTRUCTION RVTD CNG FUELING STATION ELECTRICAL SITE PLAN
7.110004-E-003 ADROIT CONSTRUCTION RVTD CNG FUELING STATION ELECTRICAL DETAILS

APPROVED FOR CONSTRUCTION
DATE: 10/7/11



HUNT, GUILLOT & ASSOCIATES, L.L.C.
CONSULTING ENGINEERS AND PROJECT MANAGERS
P.O. BOX 580 RUSTON, LA 71273

MODEL ID:

CONFIDENTIAL
THESE DESIGNS AND DRAWINGS ARE THE EXCLUSIVE PROPERTY OF:
HUNT, GUILLOT & ASSOCIATES, RUSTON, LA.
NO COPY OR REPRODUCTION MAY BE MADE WITHOUT WRITTEN APPROVAL.

ADROIT CONSTRUCTION
RVTD CNG FUELING STATION
ONE-LINE/GENERAL NOTES

DESIGNED BY	JRE	9/9/11	CHECKED BY	DWG	9/14/11
DRAWN BY	JRE	9/9/11	APPROVED BY	RSO	9/14/11
PLOT AT 1: 1	DATE: 9/6/11	HGA JOB NO: 7.110004	HGA ITEM NO:		
SCALE	DRAWING NUMBER	REV.			
N.T.S.	7.110004-E-001	0			

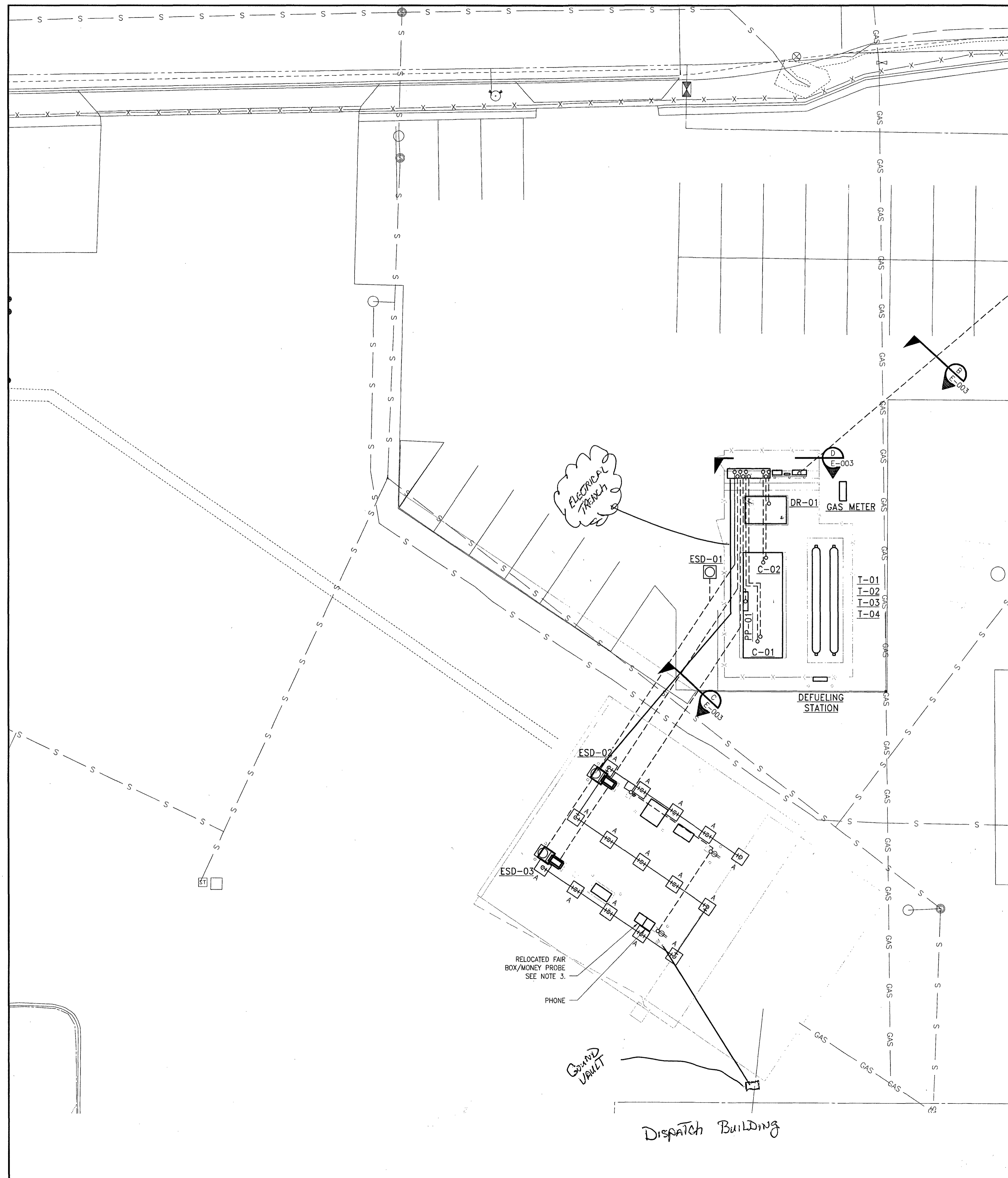

Electrical As Built for RVTB

North

NOTES:

- ELECTRICAL CONTRACTOR SHALL RUN ALL NEW CIRCUITRY IN GRC CONDUIT OVERHEAD. ELECTRICAL CONTRACTOR SHALL SECURE ALL NEW OVERHEAD CONDUIT RUNS TO EXISTING STRUCTURE AS REQUIRED.
- ELECTRICAL CONTRACTOR SHALL INSTALL ALL ELECTRICAL IN ACCORDANCE WITH LATEST EDITION OF NATIONAL ELECTRICAL CODE AND ANY OTHER NATIONAL, STATE, OR LOCAL CODES.
- ELECTRICAL CONTRACTOR SHALL INTERCEPT THE EXISTING FAIR BOX/MONEY PROBE WIRE AND REROUTE IT TO THE NEW LOCATION ALONG WITH 2-2" SPARE CONDUITS.

EQUIPMENT IDENTIFICATION:

EQUIP. NO.	DESCRIPTION
C-01	CNG COMPRESSOR SKID
T-01	CNG STORAGE TANK SKID (3 TANKS STACKED)
D-01	CNG DISPENSER NO. 1 (STANDARD)
D-02	CNG DISPENSER NO. 2 (TRANSIT BUS)
FE-01	FIRE EXTINGUISHER NO. 1 (TYPE 20 B/C)
FE-02	FIRE EXTINGUISHER NO. 2 (TYPE 20 B/C)
DR-01	NATURAL GAS DRYER
PP-01	PRIORITY PANEL

LEGEND:

- EMERGENCY STOP (PUSHBUTTON)
- NEMA 3R PANEL
- CANOPY LIGHTS
- UNDERGROUND GRC CONDUIT

REFERENCE DRAWINGS:

- 7.110004-E-001 ADROIT CONSTRUCTION RVTD CNG FUELING STATION ONE-LINE/GENERAL NOTES
- 7.110004-E-003 ADROIT CONSTRUCTION RVTD CNG FUELING STATION ELECTRICAL DETAILS

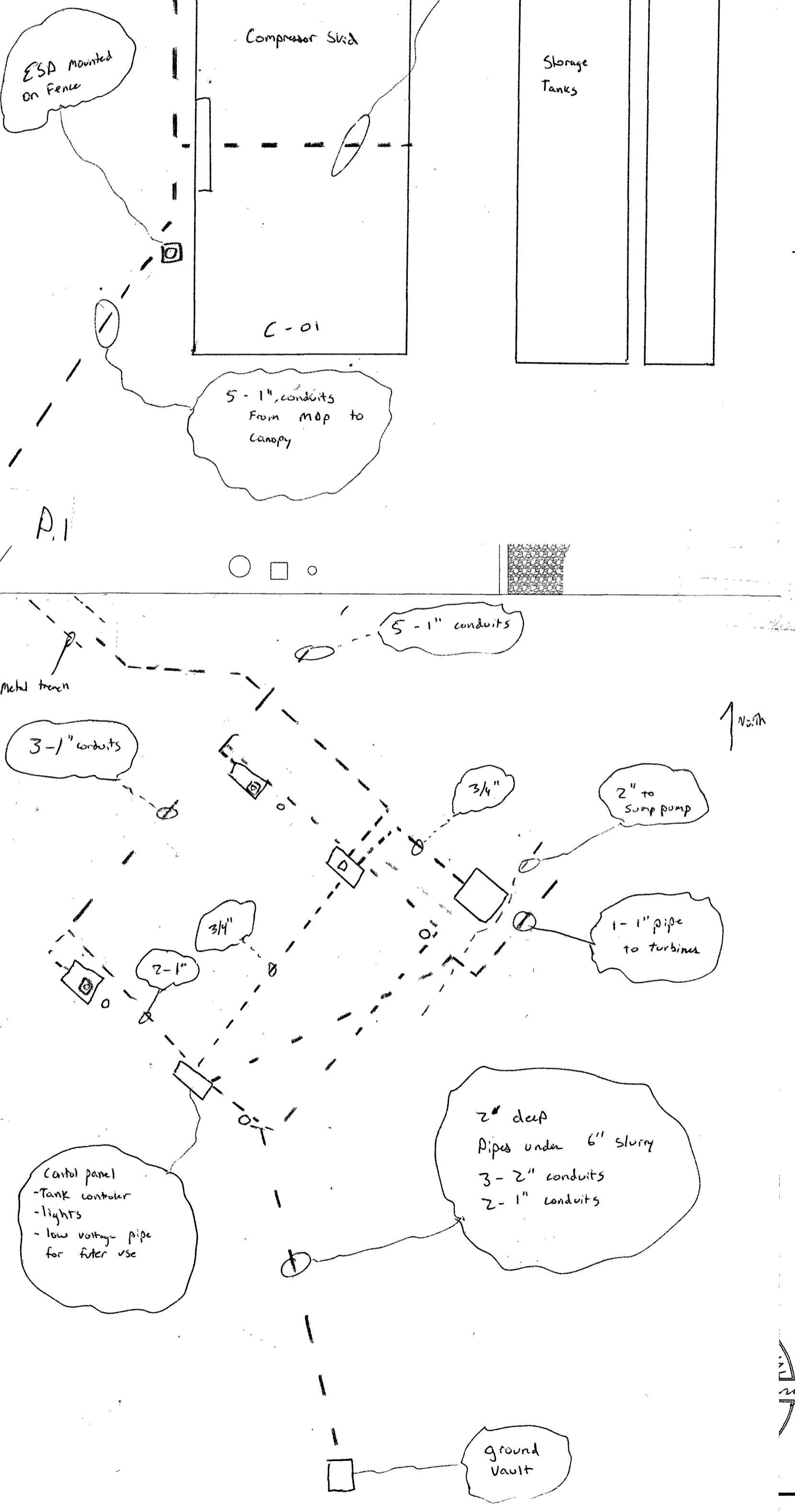

APPROVED FOR CONSTRUCTION

DATE: 10/7/11

HUNT, GUILLOT & ASSOCIATES, L.L.C.
 CONSULTING ENGINEERS AND PROJECT MANAGERS
 P.O. BOX 580 RUSTON, LA 71273

CONFIDENTIAL
 THESE DESIGNS AND DRAWINGS ARE THE EXCLUSIVE PROPERTY OF:
 HUNTY, GUILLOT & ASSOCIATES, RUSTON, LA.
 NO COPY OR REPRODUCTION MAY BE MADE WITHOUT WRITTEN APPROVAL.

**ADROIT CONSTRUCTION
 RVTD CNG FUELING STATION
 ELECTRICAL SITE PLAN**

DESIGNED BY	JRE	9/6/11	CHECKED BY	DWG	8/23/11
DRAWN BY	JRE	9/6/11	APPROVED BY	RSO	8/29/11
PLOT AT 1: 1	DATE: 8/23/11	HGA JOB NO: 7.110004	HGA ITEM NO:		
SCALE	1/8" = 1'-0"	DRAWING NUMBER	7.110004-E-002	REV.	0

A.2

Dispatch Bid.

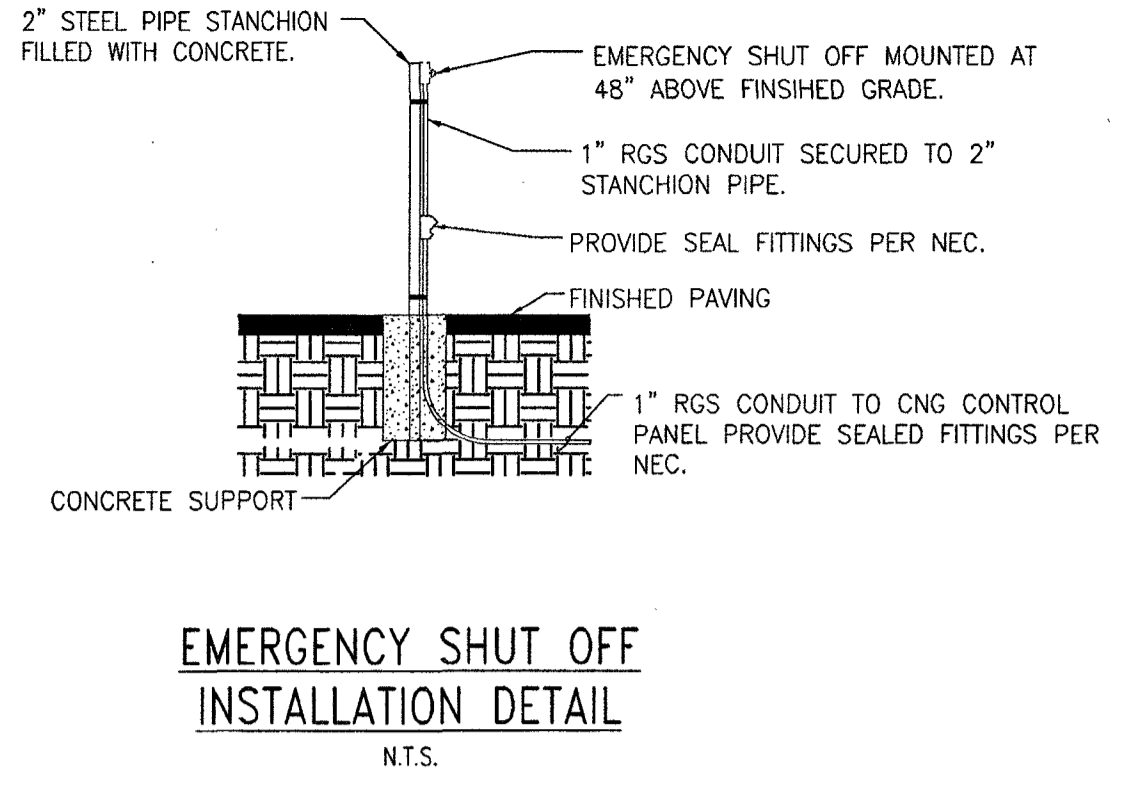
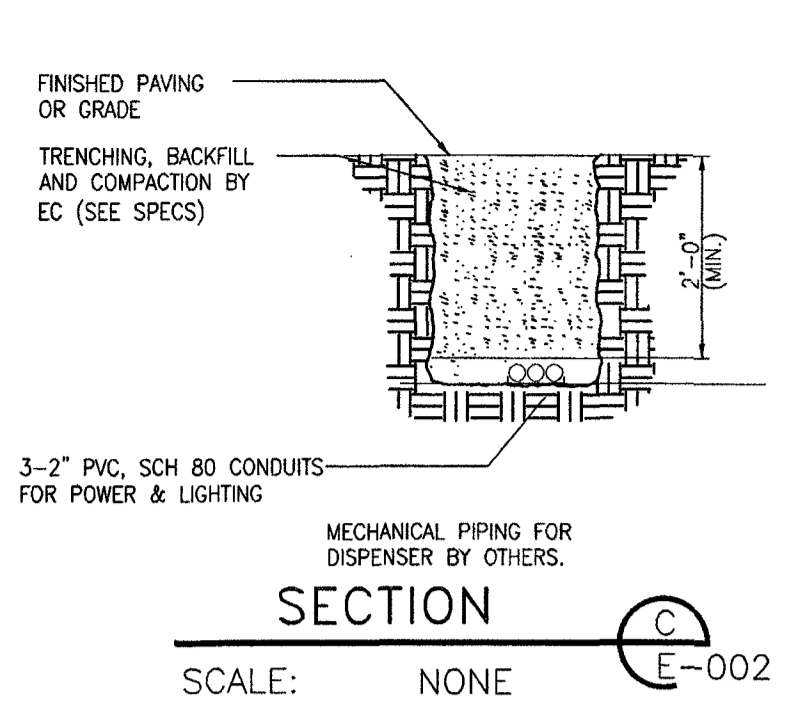
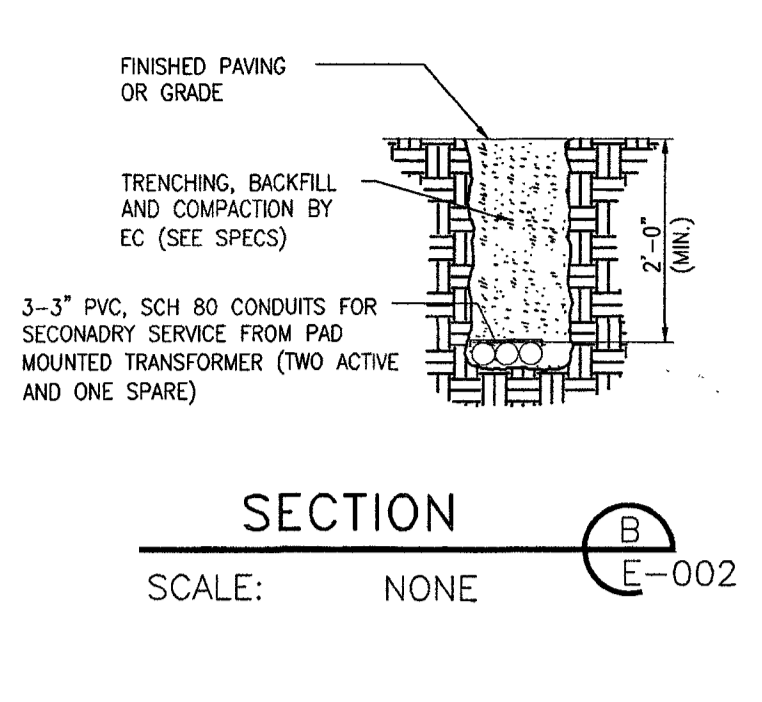
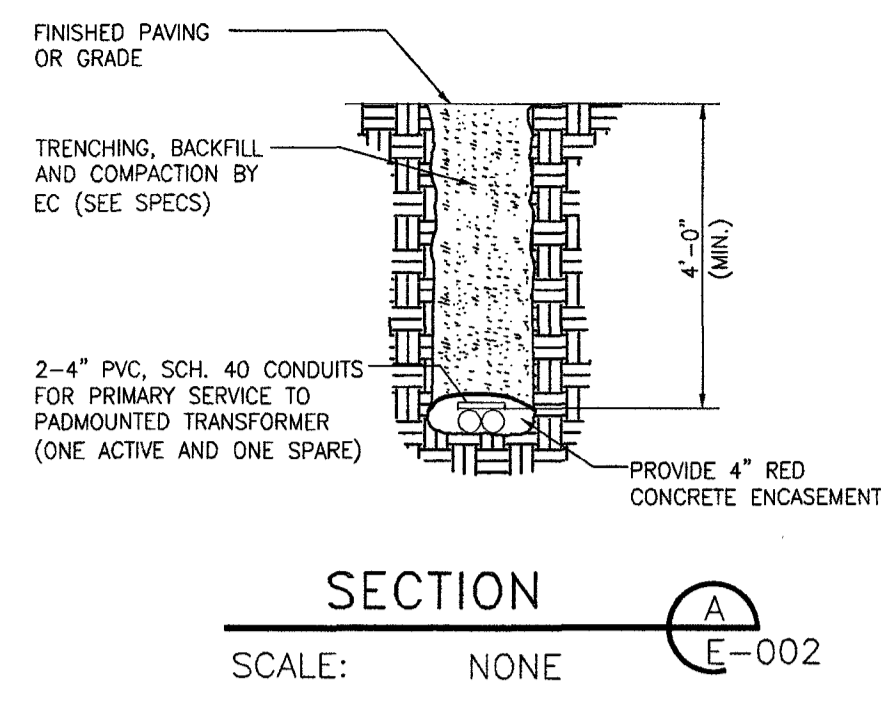

NOTES:
 1. ELECTRICAL CONTRACTOR SHALL RUN ALL NEW CIRCUITRY IN GRC CONDUIT OVERHEAD. ELECTRICAL CONTRACTOR SHALL SECURE ALL NEW OVERHEAD CONDUIT RUNS TO EXISTING STRUCTURE AS REQUIRED.

REFERENCE DRAWINGS:
 7.110004-E-001 ADRUIT CONSTRUCTION RVRTD CNG FUELING STATION ONE-LINE/GENERAL NOTES
 7.110004-E-002 ADRUIT CONSTRUCTION RVRTD CNG FUELING STATION ELECTRICAL SITE PLAN

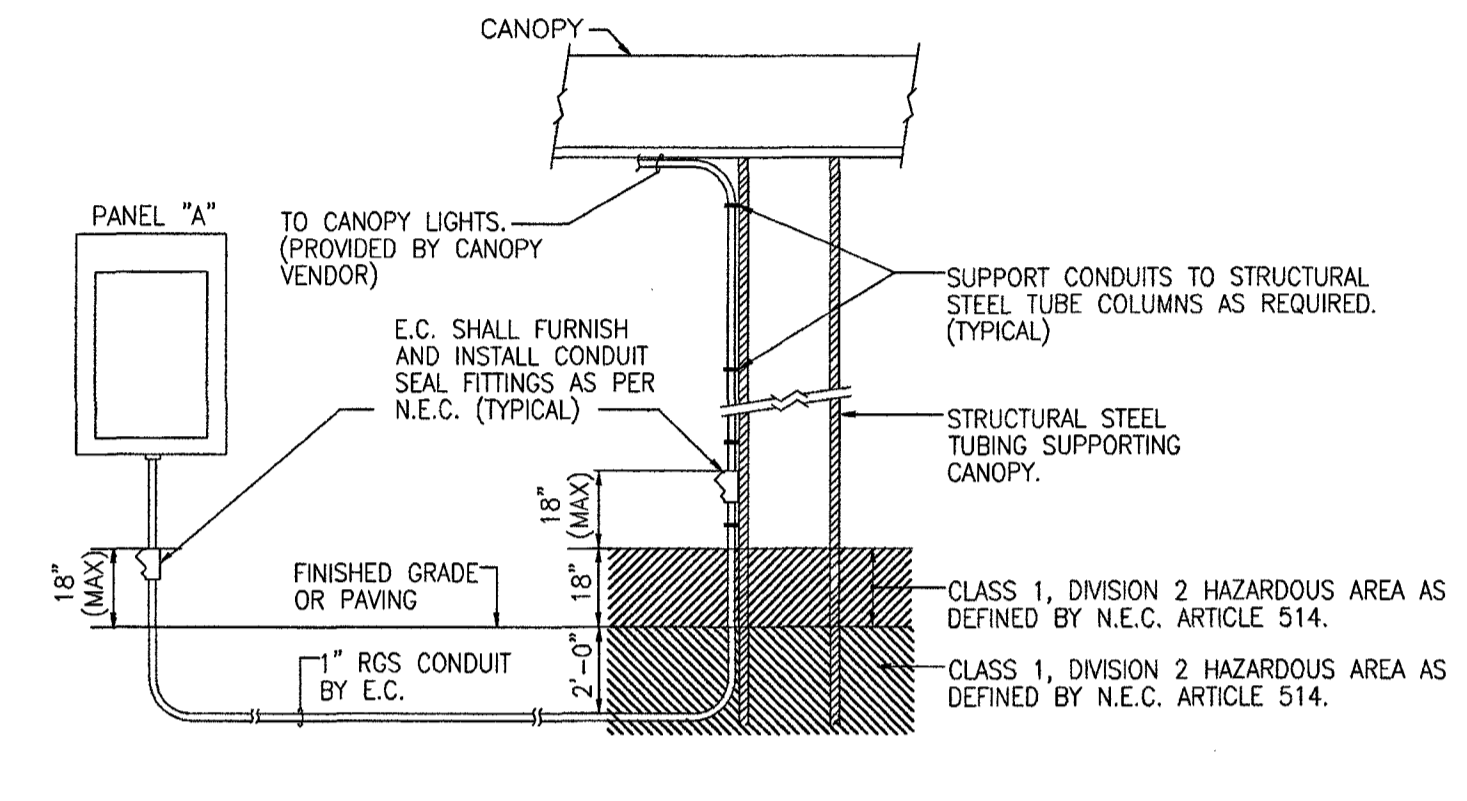

NOTES:
 1. ALL WIRING (CONDUCTORS) FOR THE FUEL CANOPY LIGHTS SHALL BE FURNISHED AND INSTALLED BY E.C.

DISPENSER CANOPY LIGHTING CONDUIT INSTALLATION DETAIL
 (LOOKING NORTHWEST)

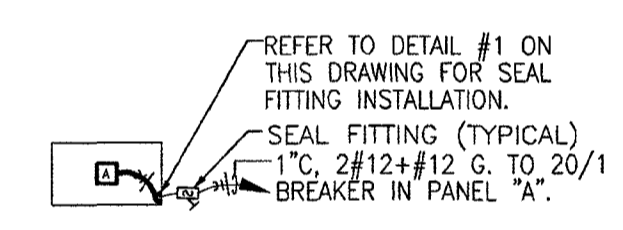

CNG DISPENSER CANOPY LIGHTING PLAN
 N.T.S.

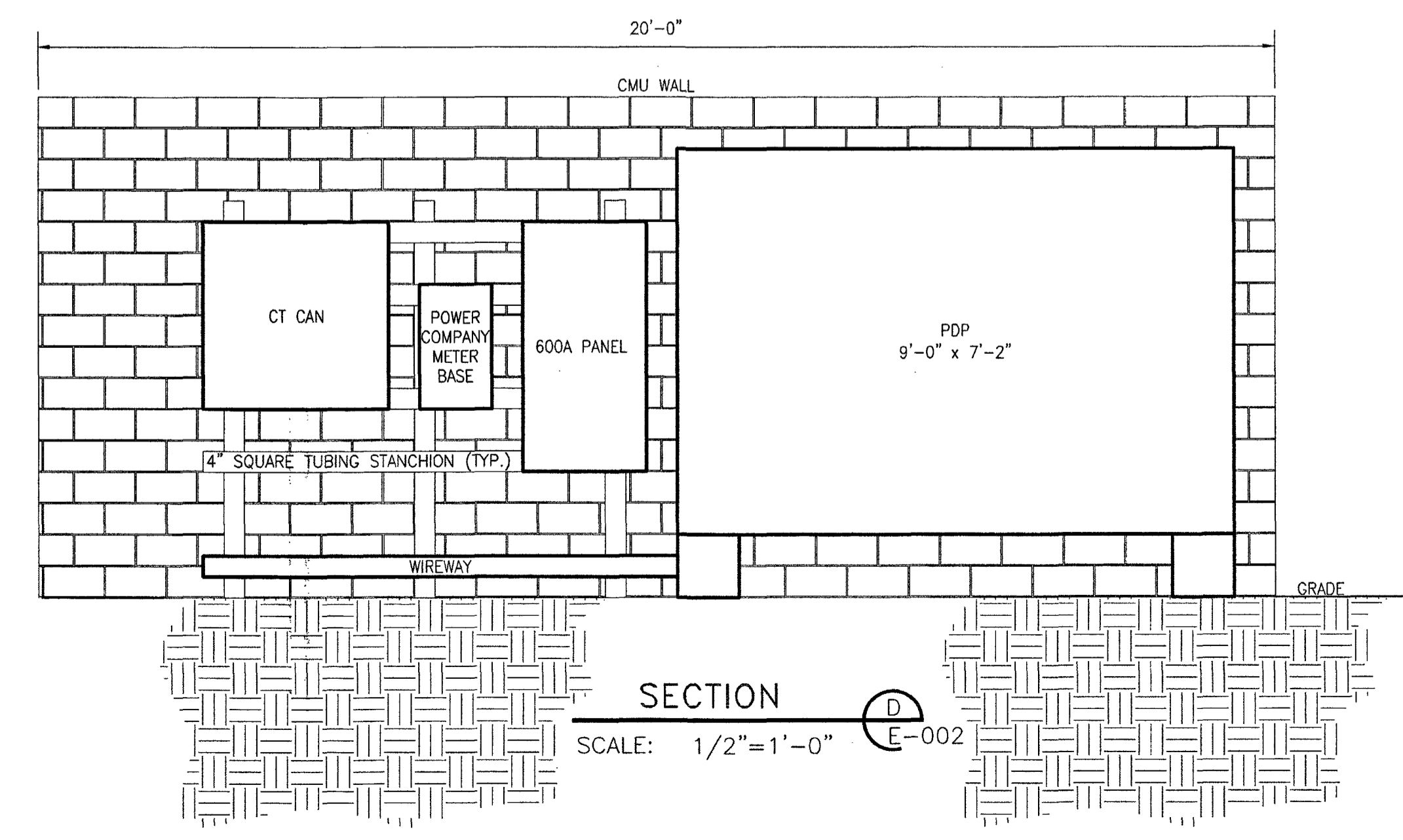

APPROVED FOR CONSTRUCTION
 DATE: 10/7/11



HUNT, GUILLOT & ASSOCIATES, L.L.C.
 CONSULTING ENGINEERS AND PROJECT MANAGERS
 P.O. BOX 580 RUSTON, LA 71273
 MODEL ID:

CONFIDENTIAL
 THESE DESIGNS AND DRAWINGS ARE THE EXCLUSIVE PROPERTY OF:
 HUNT, GUILLOT & ASSOCIATES, RUSTON, LA.
 NO COPY OR REPRODUCTION MAY BE MADE WITHOUT WRITTEN APPROVAL.
ADRUIT CONSTRUCTION
 RVRTD CNG FUELING STATION
 ELECTRICAL DETAILS

DESIGNED BY	JRE	9/6/11	CHECKED BY	DWG	9/14/11
DRAWN BY	JRE	9/6/11	APPROVED BY	RSO	9/14/11
PLOT AT 1: 1	DATE:	9/6/11	HGA JOB NO:	7.110004	HGA ITEM NO:
0	ISSUED FOR CONSTRUCTION	DWG	10/7/11	RSO	10/7/11
REV.	DESCRIPTION	CHK.	DATE	APP.	DATE
				SCALE	DRAWING NUMBER
				N.T.S.	7.110004-E-003
					REV.
					0

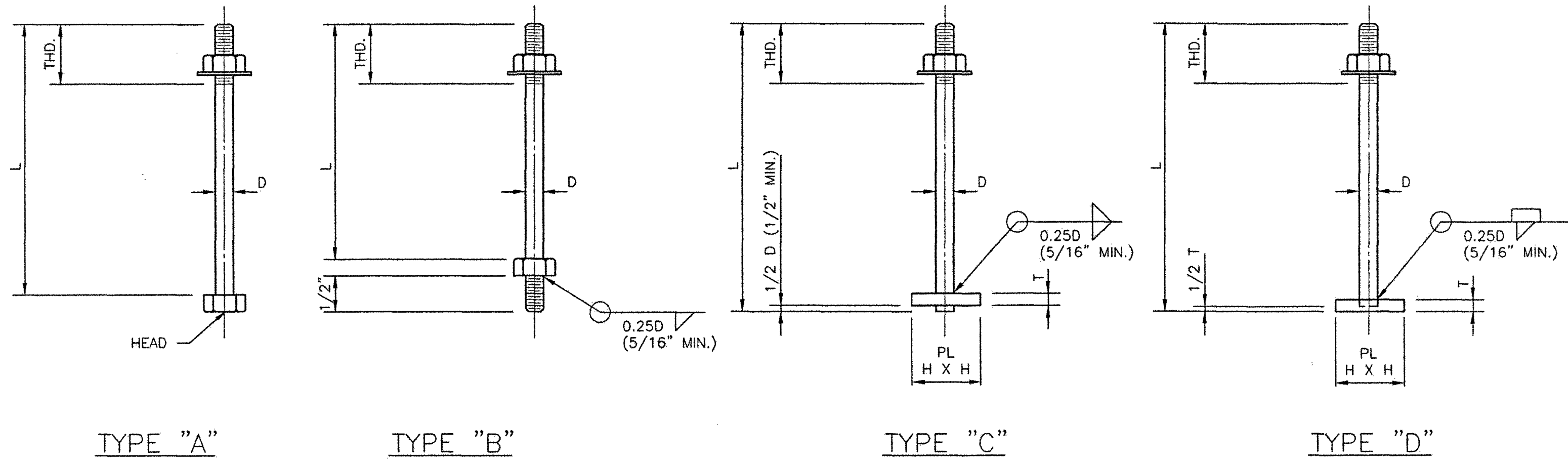

TYPE "A"

TYPE "B"

TYPE "C"

TYPE "D"

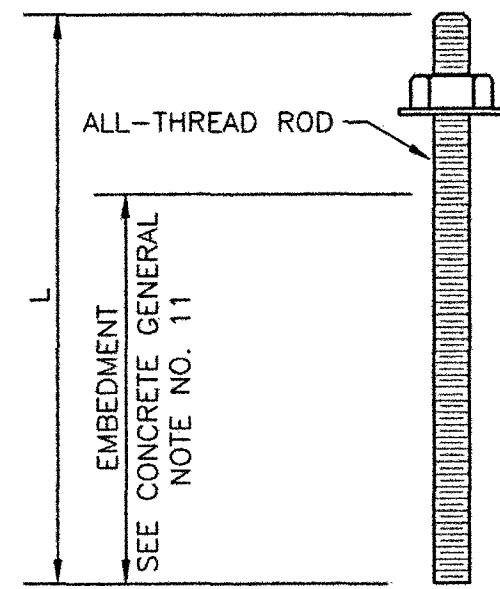

TYPE "E"

ANCHOR RODS USING CHEMICAL ANCHORING SYSTEM

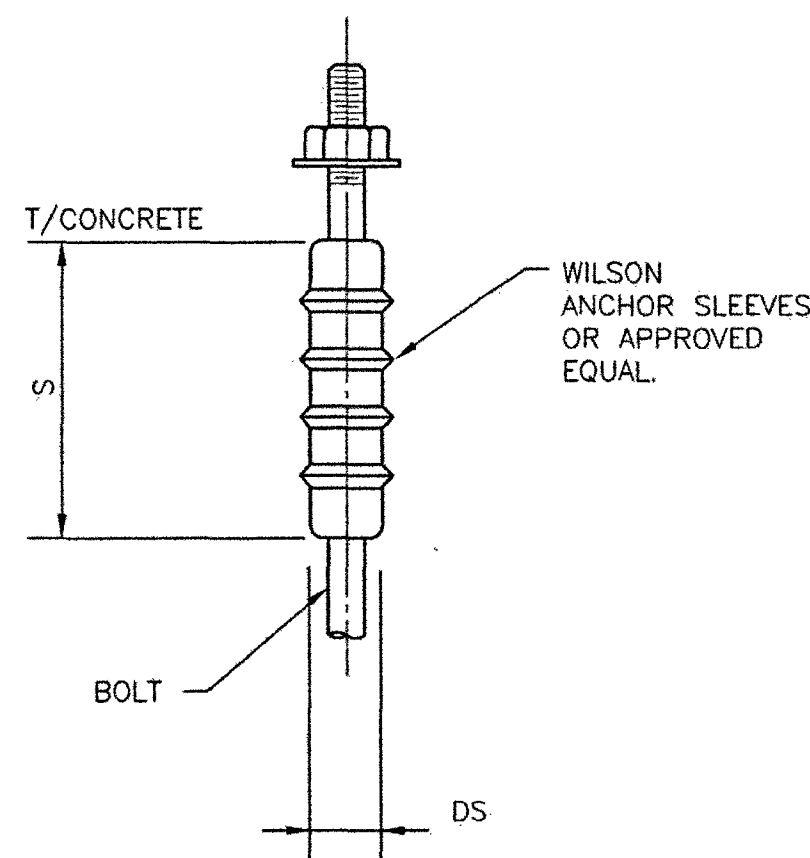

Typ. ANCHOR ROD SLEEVE DETAIL

BOLT DIA. D	LENGTH, L					MIN. THD.	PLATE		SLEEVE
	TYPE WITHOUT SLEEVE		TYPE WITH SLEEVE				H X H	T	DS X S
	A & B	C & D	A & B	C & D					
3/8"	9"		1'-0"		4"			2"x5"	
1/2"	11"		1'-1"		4"			2"x5"	
5/8"	1'-1"		1'-3"		4"			2"x7"	
3/4"	1'-4"	1'-2"	1'-7"	1'-3"	4"	3"x3"	3/4"	2"x7"	
7/8"	1'-6"	1'-3"	1'-8"	1'-5"	4"	3"x3"	3/4"	2"x7"	
1"	1'-9"	1'-4"	2'-1"	1'-8"	4 1/2"	4"x4"	3/4"	3"x10"	
1 1/8"	1'-11"	1'-6"	2'-5"	2'-0"	4 1/2"	4"x4"	3/4"	3"x10"	
1 1/4"	2'-1"	1'-8"	2'-7"	2'-3"	5"	4"x4"	1"	3"x10"	
1 3/8"	2'-3"	1'-9"	2'-11"	2'-5"	5"	5"x5"	1"	4"x1'-3"	
1 1/2"		2'-0"	2'-8"	2'-5"	5 1/2"	5"x5"	1"	4"x1'-3"	
1 3/4"		2'-4"	3'-1"	2'-5"	6"	6"x6"	1 1/4"	4"x1'-3"	
2"		2'-6"	3'-2"	2'-5"	6"	7"x7"	1 1/2"	4"x1'-6"	
2 1/4"		2'-9"	3'-7"	3'-0"	6 1/2"	8"x8"	1 3/4"	4"x1'-6"	
2 1/2"		3'-0"	4'-0"	4'-0"	6 1/2"	8"x8"	1 3/4"	6"x2'-0"	
2 3/4"		3'-3"	4'-5"	4'-5"	7"	9"x9"	1 3/4"	6"x2'-0"	
3"		3'-6"	4'-9"	4'-9"	7"	10"x10"	2"	6"x2'-0"	

* SCHEDULE DOES NOT INCLUDE TYPE "E"

ANCHOR ROD NOTES

- ANCHOR RODS SHALL MEET THE REQUIREMENTS OF ASTM F1554, GRADE 36 UNLESS OTHERWISE NOTED.
- ALL ANCHOR RODS AND NUTS SHALL BE HOT DIPPED GALVANIZED PER ASTM A123 WITH NUTS RETAPPED.
- ANCHOR RODS SHALL BE FURNISHED WITH HEX NUTS AND CUT WASHERS OF SPECIFICATIONS COMPATIBLE WITH THOSE OF THE THREADED SHANKS UNLESS OTHERWISE NOTED. MINIMUM WASHER SIZE AND THICKNESS SHALL COMPLY WITH THE AISC MANUAL OF STEEL CONSTRUCTION.
- THREAD LENGTH SHALL BE AS SHOWN IN ANCHOR ROD STANDARD UNLESS OTHERWISE CALLED FOR IN ANCHOR ROD DESIGNATION.
- ANCHOR ROD LENGTH (L) SHALL BE AS SHOWN IN ANCHOR ROD STANDARD UNLESS OTHERWISE CALLED FOR IN ANCHOR ROD DESIGNATION.
- ANCHOR ROD DESIGNATION SYSTEM.
 - ONLY IF SLEEVE IS REQUIRED.
 - THREAD LENGTH IN INCHES IF NOT AS SHOWN IN STANDARD.
 - 1 1/4" 1'-10" ASNB
 - IF 2-NUTS ARE REQUIRED
 - ANCHOR ROD TYPE.
 - ANCHOR ROD LENGTH (L) ONLY IF NOT AS SHOWN IN THE ANCHOR ROD SCHEDULE.
 - ANCHOR ROD DIAMETER (D).
- ALL ANCHOR RODS TO BE TAGGED BY THE FABRICATOR THUS:
 - 1 1/4" 1'-10" ASNB, XXXX
 - DWG. NO. ON WHICH DESIGNATION IS SHOWN.
 - ANCHOR ROD DESIGNATION.
- ANCHOR RODS SHALL BE CLEAN AND FREE OF ANY OILS OR OTHER FOREIGN MATERIALS PRIOR TO PLACEMENT.
- MEANS SHALL BE USED TO PREVENT CONCRETE FROM CONTACTING THE PROJECTING PART OF THE ANCHOR ROD.

CONCRETE & REINFORCEMENT GENERAL NOTES

- DESIGN, MATERIAL, AND WORKMANSHIP SHALL BE IN ACCORDANCE WITH THE CURRENT EDITION OF THE FOLLOWING STANDARDS:
 - ACI 318 BUILDING CODE REQUIREMENTS FOR REINFORCED CONCRETE.
 - SP66 ACI DETAILING MANUAL.
 - ACI 301 SPECIFICATIONS FOR STRUCTURAL CONCRETE FOR BUILDINGS.
 - CRSI RECOMMENDED PRACTICE FOR PLACING REINFORCING STEEL.
- CONCRETE SHALL DEVELOP 4000 PSI MINIMUM COMPRESSIVE STRENGTH AT 28 DAYS, UNLESS NOTED OTHERWISE.
- REINFORCING STEEL SHALL BE DEFORMED BARS CONFORMING TO ASTM A615 GRADE 60.
- WELDED WIRE FABRIC SHALL CONFORM TO ASTM A185, (FLAT SHEETS ONLY).
- UNLESS NOTED OTHERWISE, CONCRETE COVER OVER REINFORCING SHALL BE:
 - 3" WHEN THE CONCRETE IS PLACED DIRECTLY AGAINST THE GROUND.
 - 2" FOR BARS LARGER THAN NO. 5, AND 1 1/2" FOR NO. 5 AND SMALLER, IF AFTER REMOVAL OF FORMS THE CONCRETE IS EXPOSED DIRECTLY TO WEATHER OR GROUND.
 - 1" IN SLABS AND WALLS, AND 1 1/2" FOR BEAMS AND COLUMNS NOT EXPOSED DIRECTLY TO WEATHER OR GROUND.
- UNLESS OTHERWISE SHOWN, THE MINIMUM LAP FOR BAR SPLICES SHALL BE PER ACI 318.
- ALL REINFORCING HOOKS SHALL BE STANDARD HOOKS AS DEFINED BY ACI 318.
- ALL EXPOSED EDGES OF CONCRETE SHALL HAVE A 1 INCH, 45 DEGREE CHAMFER.
- A 1/2" BITUMASTIC PREFORMED EXPANSION JOINT SHALL BE PLACED AT ALL LOCATIONS NOTED ON THE DRAWINGS AND ALSO AROUND ALL FOUNDATIONS WHICH PROJECT THROUGH CONCRETE SLABS. ALL EXPANSION JOINTS SHALL BE SEALED WITH "SLI" AS MANUFACTURED BY SONNEBORN OR APPROVED EQUAL. PROCEDURES AND WORKMANSHIP SHALL CONFORM TO MANUFACTURER'S RECOMMENDATIONS. CONTROL JOINTS SHALL BE PLACED AT 15' EACH DIRECTION, UNLESS NOTED OTHERWISE.
- PRIOR TO PLACING CONCRETE, REFER TO PLUMBING, PIPING AND ELECTRICAL DRAWINGS FOR UNDERGROUND AND EMBEDDED ITEMS NOT SHOWN ON STRUCTURAL DRAWINGS.
- ANCHOR RODS AND REINFORCING BARS, WHERE INDICATED TO BE INSTALLED USING A CHEMICAL ANCHORING SYSTEM, SHALL BE FIELD DRILLED AND INSTALLED USING THE "HILTI" HIT BY 150 ANCHORING SYSTEM OR APPROVED EQUAL. THE CONTRACTOR SHALL INSTALL PER ANCHORING SYSTEM PRODUCT INSTRUCTIONS TO FULLY DEVELOP THE ANCHOR BOLTS OR REINFORCEMENT BARS. (THIS WILL INCLUDE, BUT NOT BE LIMITED TO THE DRILLED HOLE DIAMETER AND DEPTH).
- ALL NEW CONCRETE SHALL BE BONDED TO EXISTING CONCRETE WITH THE USE OF AN ASTM C881, TYPE I OR II, GRADE 1, 2, OR 3, CLASS B OR C EPOXY RESIN ADHESIVE. EXISTING CONCRETE WHICH IS TO BE BONDED TO NEW CONCRETE SHALL BE ABRASIVE BLASTED, BUSH HAMMERED OR OTHERWISE BROUGHT TO A FULL AMPLITUDE OF 1". ALL SURFACES SHALL BE INSPECTED AFTER BEING ROUGHENED AND CLEANED. ALL LOOSE PIECES OF CONCRETE SHALL BE REMOVED AND ALL CRACKS SHALL BE PRESSURE GROUTED WITH AN EPOXY RESIN GROUT AS SPECIFIED ABOVE. PROCEDURES AND WORKMANSHIP SHALL CONFORM TO "STANDARD SPECIFICATIONS FOR BONDING PLASTIC CONCRETE TO HARDENED CONCRETE WITH A MULTI-COMPONENT EPOXY ADHESIVE", ACI 503.2 AND AS RECOMMENDED BY THE MANUFACTURER. GROUT MATERIAL SHALL BE APPROVED BY THE ENGINEER.
- EXPANSION BOLTS SHALL BE HILTI-KWIK BOLT 3 OR ENGINEER APPROVED EQUAL BOLTS SHALL BE TORQUED TO MANUFACTURER'S STANDARD TORQUE VALUES.
- GROUT FOR COLUMN BASE PLATES SHALL BE "FIVE STAR" NON-SHRINK CEMENT GROUT BY U.S. GROUT CORPORATION OR APPROVED EQUAL UNLESS OTHERWISE NOTED.
- ALL COLUMN BASE PLATES SHALL BE GROUTED TO PROVIDE FULL UNIFORM LOAD TRANSFER TO THE CONCRETE FOUNDATIONS. SHIMS SHALL BE REMOVED AND THE VOIDS SHALL BE GROUTED AFTER THE GROUT HAS CURED. NUTS SHALL BE TIGHTENED AFTER THE GROUT HAS CURED.
- REINFORCING BARS SHALL BE SUPPORTED ON CHAIRS AND SPACERS PER ACI 315.
- ALL WATERSTOPS SHALL BE ADEKA ULTRA SEAL P-201 OR ADEKA ULTRA SEAL P-201 WITH KBA-1510FP, OR APPROVED EQUAL.

SPECIAL INSPECTION - SITE AND FOUNDATIONS

- SPECIAL INSPECTIONS SHALL MEET THE REQUIREMENTS OF IBC SECTION 1704. SPECIAL INSPECTOR ADMINISTRATOR(S) SHALL BE HIRED TO PERFORM THE REQUIRED SPECIAL INSPECTIONS. THE NAMES OF PERSONS OR FIRMS WHO ARE TO PERFORM THE SPECIAL INSPECTIONS SHALL BE FORWARDED TO THE BUILDING OFFICIAL FOR APPROVAL. THE SPECIAL INSPECTOR ADMINISTRATOR(S) SHALL COMPLETE AND SUBMIT ALL FORMS REQUIRED BY THE CITY OF
- THE SPECIAL INSPECTOR ADMINISTRATOR(S) SHALL:
 - OBSERVE THE WORK ASSIGNED FOR CONFORMANCE TO THE APPROVED DRAWING AND SPECIFICATIONS.
 - FURNISH MONTHLY INSPECTION REPORTS TO THE REGISTERED DESIGN PROFESSIONAL IN RESPONSIBLE CHARGE AND BUILDING OFFICIAL. DISCREPANCIES SHALL BE BROUGHT TO THE IMMEDIATE ATTENTION OF THE CONTRACTOR FOR CORRECTION, THEN, IF NOT CORRECTED, TO THE DESIGN PROFESSIONAL IN RESPONSIBLE CHARGE AND THE BUILDING OFFICIAL.
 - SUBMIT TO THE DESIGN PROFESSIONAL IN RESPONSIBLE CHARGE AND THE BUILDING OFFICIAL A SIGNED FINAL REPORT STATING THAT THE WORK WAS IN CONFORMANCE WITH THE APPROVED DRAWINGS AND SPECIFICATIONS AND THE APPLICABLE WORKMANSHIP PROVISIONS OF THE IBC.
- SPECIAL INSPECTION NOTES:
 - CONTINUOUS SPECIAL INSPECTION IS ALWAYS REQUIRED DURING THE PERFORMANCE OF THE WORK UNLESS SPECIFICALLY NOTED BELOW.
 - IT IS THE RESPONSIBILITY OF THE CONTRACTOR TO PROVIDE THE SPECIAL INSPECTOR ADMINISTRATOR(S) WITH ADVANCE NOTICE, NO LESS THAN ONE WORKING DAY, OF THE INITIATION OF ANY WORK TO HAVE SPECIAL INSPECTIONS. ALL WORK PERFORMED WITHOUT REQUIRED SPECIAL INSPECTION WILL BE SUBJECT TO REMOVAL.
- TYPES OF WORK REQUIRING SPECIAL INSPECTION ARE:
 - SPECIAL INSPECTION FOR EXISTING SOIL CONDITIONS, DURING SITE PREPARATION AND FILL PLACEMENT, TO ENSURE LOAD-BEARING REQUIREMENTS IN COMPLIANCE WITH IBC SECTION 1704.7 EXCEPT AS ALLOWED IN IBC SECTION 1704.7.
 - SITE PREPARATION:
 - PRIOR TO PLACEMENT OF THE PREPARED FILL, THE SPECIAL INSPECTOR SHALL DETERMINE THAT THE SITE HAS BEEN PREPARED IN ACCORDANCE WITH THE SPECIFICATION. (FREQUENCY OF INSPECTION-ONCE EVERY 500 SQUARE FOOT AREA OR LESS)
 - DURING FILL PLACEMENT:
 - DURING PLACEMENT AND COMPACTION OF FILL MATERIAL, THE SPECIAL INSPECTOR SHALL DETERMINE THAT THE MATERIAL BEING USED, MOISTURE CONTENT, AND THE MAXIMUM LIFT THICKNESS COMPLY WITH THE SPECIFICATION. (FREQUENCY OF INSPECTION-ONCE EVERY 500 SQUARE FOOT AREA OR LESS)
 - EVALUATION OF IN-PLACE DENSITY:
 - THE SPECIAL INSPECTOR SHALL DETERMINE, AT THE APPROVED FREQUENCY, THAT THE IN-PLACE DRY DENSITY OF THE COMPACTED FILL AND THE FOUNDATION SUBGRADE COMPLIES WITH THE SPECIFICATION. (FREQUENCY OF INSPECTION-ONCE EVERY 500 SQUARE FOOT AREA OR LESS)
 - CONCRETE CONSTRUCTION AS REQUIRED BY IBC SECTION 1704.4 AND TABLE 1704.4, EXCEPT AS ALLOWED IN IBC SECTION 1704.4.
 - INSPECT SOILS BELOW ALL FOOTINGS FOR ADEQUATE BEARING CAPACITY AND CONSISTENCY WITH GEOTECHNICAL REPORT. INSPECT REMOVAL OF UNSUITABLE MATERIAL AND PREPARATIONS OF SUBGRADE PRIOR TO PLACEMENT OF CONTROLLED FILL. (CONTINUOUS INSPECTION REQUIRED)
 - INSPECTION OF REINFORCING STEEL AND PLACEMENT. THIS INSPECTION SHALL INCLUDE CHECKING REBAR SIZE, SPACING, NUMBER, LAP SPLICES, DEVELOPMENT LENGTH FOR COMPLIANCE WITH APPROVED DRAWINGS. ALSO VERIFY MATERIAL CERTIFICATION REPORT. (INSPECT EACH FOUNDATION)
 - INSPECTION OF BOLTS TO BE INSTALLED IN CONCRETE PRIOR TO AND DURING PLACEMENT OF CONCRETE. THIS INSPECTION SHALL INCLUDE CHECKING BOLT SIZES, LOCATION, BOLT PATTERN AND ORIENTATION, ELEVATION, ANCHORAGE DETAIL AND EMBEDMENT LENGTH FOR COMPLIANCE WITH APPROVED DRAWING. (CONTINUOUS INSPECTION REQUIRED)
 - VERIFYING USE OF THE REQUIRED MIX DESIGN. THIS INSPECTION SHALL INCLUDE CHECKING BATCH PLANT'S TICKET FOR CONCRETE MIX, ADDITIVES, WATER CEMENT RATIOS AND THE TIME WHEN WATER IS ADDED TO THE MIX. (FREQUENCY OF INSPECTION-ONCE EVERY 50 CYD OF CONCRETE MINIMUM-ONCE PER FOUNDATION)
 - AT THE TIME FRESH CONCRETE IS SAMPLED TO FABRICATE SPECIMENS FOR STRENGTH TESTS. ALSO PERFORM SLUMP AND AIR CONTENT TESTS, AND DETERMINE THE TEMPERATURE OF THE CONCRETE. (CONTINUOUS INSPECTION REQUIRED)
 - INSPECTION OF CONCRETE PLACEMENT FOR PROPER APPLICATION TECHNIQUES. THE INSPECTOR SHALL OBSERVE THAT THE CONCRETE IS NOT SEGREGATED DURING PLACEMENT AND PROPERLY VIBRATED AND THE PLACEMENT IS COMPLETED WITHIN THE TIME PERIOD SPECIFIED. (CONTINUOUS INSPECTION REQUIRED)
 - INSPECTION OF MAINTENANCE OF SPECIFIED CURING TEMPERATURE AND TECHNIQUES, INCLUDING PROTECTION OF THE CONCRETE FROM HOT/COLD WEATHER CONDITIONS. (INSPECT EACH FOUNDATION)

APPROVED FOR CONSTRUCTION

DATE: 10/12/11



Expires: 4/12/13

HUNT, GUILLOT & ASSOCIATES, L.L.C.
CONSULTING ENGINEERS AND PROJECT MANAGERS
P.O. BOX 580 RUSTON, LA 71273

CONFIDENTIAL
THESE DESIGNS AND DRAWINGS ARE THE EXCLUSIVE PROPERTY OF:
HUNT, GUILLOT & ASSOCIATES, RUSTON, LA.
NO COPY OR REPRODUCTION MAY BE MADE WITHOUT WRITTEN APPROVAL.

CONCRETE GENERAL NOTES
SPECIAL INSPECTION NOTES
ANCHOR BOLT DETAILS

REV.	DESCRIPTION	CHK.	DATE	APP.	DATE	SCALE	DRAWING NUMBER	REV.
0	ISSUED FOR CONSTRUCTION	CEH	10-12-11	RSO	10-12-11	NONE	STD-F-001	0
A	ISSUED FOR APPROVAL	CEH	9-14-11	RSO	9-14-11			

DESIGNED BY	HGA	11-13-08	CHECKED BY	CEH	9-14-11
DRAWN BY	ADM	1-23-03	APPROVED BY	RSO	9-14-11
PLOT AT 1: 1-1	DATE: 1-23-03	HGA JOB NO: 7110004	HGA ITEM NO:		

GENERAL STRUCTURAL NOTES

CODE REQUIREMENTS:

CONFORM TO THE 2009 INTERNATIONAL BUILDING CODE AS AMENDED BY THE 2010 OREGON STRUCTURAL SPECIALTY CODE, REFERENCED HERE AFTER AS IBC.

DESIGN CRITERIA:

DESIGN WAS BASED ON THE STRENGTH AND DEFLECTION CRITERIA OF THE IBC. IN ADDITION TO THE DEAD LOADS, THE FOLLOWING LOADS WERE USED FOR DESIGN, WITH LIVE LOADS REDUCED PER IBC:

ROOF SNOW LOAD: 25 PSF

BASIC WIND SPEED (3- SECOND GUST): 95 MPH, EXPOSURE B

SITE CLASS: D

SDS = 0.516

RESPONSE MODIFICATION FACTOR R: 1.25

ALLOWABLE SOIL BEARING PRESSURE: 1500 PSF (ASSUMED).

EXISTING CONDITIONS:

THE CONTRACTOR SHALL FIELD VERIFY ALL EXISTING CONDITIONS, DIMENSIONS AND ELEVATIONS. THE CONTRACTOR SHALL NOTIFY THE ARCHITECT/ENGINEER OF ANY DISCREPANCIES FROM CONDITIONS SHOWN ON THE DRAWINGS PRIOR TO THE START OF THE WORK.

TEMPORARY CONDITIONS:

THE CONTRACTOR SHALL BE RESPONSIBLE FOR STRUCTURAL STABILITY OF THE NEW AND EXISTING STRUCTURES AND WALLS DURING CONSTRUCTION. THE STRUCTURE SHOWN ON THE DRAWINGS HAS BEEN DESIGNED FOR STABILITY UNDER THE FINAL CONFIGURATION ONLY.

SUBMITTALS:

SHOP DRAWINGS SHALL BE SUBMITTED TO THE ARCHITECT/ENGINEER PRIOR TO FABRICATION AND CONSTRUCTION REGARDING ALL STRUCTURAL ITEMS, INCLUDING THE FOLLOWING:

CONCRETE MIX DESIGNS (PROVIDE BREAK TEST DATA FOR EACH SUBMITTED MIX WITH A MINIMUM OF 30 TEST SPECIMENS PER MIX), CONCRETE STEEL REINFORCING, EMBEDDED STEEL ITEMS, AND STRUCTURAL STEEL.

IF THE SHOP DRAWINGS DIFFER FROM, OR ADD TO THE DESIGN OF THE STRUCTURAL DRAWINGS, THEY SHALL BE CLEARLY IDENTIFIED. ANY CHANGES TO THE STRUCTURAL DRAWINGS SHALL BE SUBMITTED TO THE ARCHITECT/ENGINEER AND ARE SUBJECT TO REVIEW AND ACCEPTANCE BY THE ENGINEER.

EARTHWORK:

PROTECT INCOMPLETE WORK FROM FLOODING DURING STORMS OR OTHER CAUSES. TAKE ALL NECESSARY PRECAUTIONS TO PREVENT DISTURBANCE OF AND TO PROPERLY DRAIN THE AREAS UPON WHICH CONCRETE IS TO BE POURED. DO NOT ALLOW WATER TO ACCUMULATE IN EXCAVATIONS. REMOVE WATER TO PREVENT SOFTENING OF THE BASE FOUNDATIONS. MAINTAIN THE EXCAVATION FREE FROM GROUND WATER FOR THE TIME REQUIRED TO COMPLETE THE WORK IN A PROPER WORKMANLIKE MANNER. REMOVE LOOSE OR DISTURBED SOIL FROM THE BOTTOMS OF EXCAVATION. FOOTINGS SHALL BEAR ON UNDISTURBED NATIVE SOIL OR ENGINEERED STRUCTURAL FILL.

WHERE COMPACTED AREAS ARE DISTURBED BY CONSTRUCTION OPERATIONS OR ADVERSE WEATHER, OVER EXCAVATE AND BACKFILL WITH 3/4" MINUS CRUSHED ROCK COMPACTED TO MINIMUM OF 92% OF THE DRY DENSITY AS MEASURED BY AASTM T100. AT DISTURBED AREAS WITHIN 3'-0" OF BUILDING FOUNDATIONS COMPACT TO MINIMUM 95% OF THE DRY DENSITY AS MEASURED BY AASTM T100.

CAST-IN-PLACE CONCRETE:

MIX DESIGN: PREPARE DESIGN MIXES FOR EACH TYPE OF CONCRETE. PROPORTION MIXES BY EITHER LABORATORY TRIAL BATCH OR FIELD EXPERIENCE METHODS, USING MATERIALS TO BE EMPLOYED ON THE WORK FOR EACH CLASS OF CONCRETE REQUIRED. FURNISH CERTIFIED REPORTS OF EACH PROPOSED MIX FOR EACH TYPE OF WORK OF THIS SECTION. THE CONTRACTOR SHALL SUBMIT CONCRETE MIX DESIGNS, ALONG WITH TEST DATA AS REQUIRED, A MINIMUM OF TWO WEEKS PRIOR TO PLACING CONCRETE.

ADMIXTURES: AIR ENTRAINING AGENT IN ACCORDANCE WITH ASTM C260 AND WATER-REDUCING ADMIXTURE CONFORMING TO ASTM 494, USED IN STRICT ACCORDANCE WITH THE MANUFACTURER'S RECOMMENDATIONS, MAY BE INCORPORATED IN CONCRETE DESIGN MIXES. AN AIR-ENTRAINING AGENT CONFORMING TO ASTM C260 SHALL BE USED IN CONCRETE MIXES FOR EXTERIOR HORIZONTAL SURFACES EXPOSED TO WEATHER. THE AMOUNT OF ENTRAINING AIR SHALL BE 5% ± 1% BY VOLUME. FLY ASH SHALL CONFORM TO ASTM C 618 AND SHALL BE LIMITED TO A 15% MAXIMUM BY CEMENT WEIGHT.

CONCRETE WORK SHALL CONFORM TO ACI 301. CONCRETE STRENGTHS SHALL BE VERIFIED BY STANDARD 28-DAY CYLINDER TESTS PER ASTM C39, AND SHALL BE AS FOLLOWS:

FOOTINGS: $f_c = 3000$ PSI AT 28 DAYS. (MINIMUM CEMENT CONTENT = 470 LBS)

(SPECIAL INSPECTION OF CONCRETE MIX IS NOT REQUIRED AS IT WAS DESIGNED TO $f_c = 2500$ PSI)

ABSOLUTE WATER/CEMENT RATIO BY WEIGHT:

$f_c = 3000$ PSI (0.54 NON-AIR ENTRAINED, 0.46 AIR ENTRAINED)

SLEEVES, OPENINGS, CONDUIT, AND OTHER EMBEDDED ITEMS NOT SHOWN ON THE STRUCTURAL DRAWINGS SHALL BE APPROVED BY THE STRUCTURAL ENGINEER BEFORE POURING.

CONCRETE REINFORCING STEEL:

REINFORCING STEEL SHALL CONFORM TO ASTM A615, GRADE 60 AND FOR DEFORMED BARS, UNLESS OTHERWISE NOTED.

REINFORCING STEEL SHALL BE DETAILED IN ACCORDANCE WITH ACI 318 LATEST EDITION ("DETAILS AND DETAILING CONCRETE REINFORCEMENT").

UNLESS NOTED OTHERWISE ON THE DRAWINGS LAP SPLICE LENGTHS SHALL BE AS FOLLOWS:

FOR CONCRETE STRENGTH $f_c = 3000$ PSI - LAP SPLICE LENGTH = 50 BAR DIAMETERS.

REINFORCING STEEL SHALL HAVE PROTECTION AS FOLLOWS:

CONDITION:	MINIMUM COVER:
CONCRETE CAST AGAINST AND PERMANENTLY EXPOSED TO EARTH:	3"
CONCRETE EXPOSED TO EARTH AND WEATHER: NO. 6 THROUGH NO. 18 BARS	2"
NO. 3 BAR, NO. 1 OR NO. 3 WIRE AND SMALLER	1 1/2"

CONCRETE ACCESSORIES:

NON-SHRINK GROUT SHALL BE A PRE-MIXED COMPOUND CONSISTING OF NON-METALLIC AGGREGATE, CEMENT, WATER REDUCING AND PLASTICIZING AGENTS, CAPABLE OF DEVELOPING A MINIMUM COMPRESSIVE STRENGTH OF 2200 PSI IN 48 HOURS AND 6000 PSI IN 28 DAYS. GROUT SHALL BE MIXED AND APPLIED IN STRICT ACCORDANCE WITH MANUFACTURER'S RECOMMENDATIONS.

METALS:

METAL PAN DECK: MINIMUM 20 GAUGE, 'G30' GALVANIZED, MANUFACTURED BY FREY-MOSS STRUCTURES; 16" WIDE x 3" TALL PANS (F_y = 50 KSI), 5+0.43 IN³ MINIMUM FOR POSITIVE BENDING, 0+0.31 IN³ MINIMUM FOR NEGATIVE BENDING).

ALL MISCELLANEOUS STEEL: ASTM A36 (F_y = 36,000 PSI), OR AS NOTED ASTM A572 (F_y = 50 KSI), WIDE FLANGE AND STRUCTURAL TEES: ASTM A992 (F_y = 50,000 PSI) OR ENGINEER APPROVED EQUAL SQUARE AND RECTANGULAR HSS; ASTM A500, GRADE "B" (F_y = 46,000 PSI).

ALL BOLTS: ASTM A325 UNLESS NOTED OTHERWISE.

THREADED RODS: ASTM A36 UNLESS NOTED OTHERWISE.

WELDING: PER AISC STANDARDS, E70XX ELECTRODE AND BY CERTIFIED WELDERS.

ALL STEEL TO HAVE SHOP COAT.

ALL EXPOSED STEEL BELOW FINISH GRADE TO BE COATED WITH ASPHALTIC PAINT PRIOR TO BACKFILLING.

ALL STEEL EXPOSED TO WEATHER SHALL BE GALVANIZED.

DESIGN, FABRICATION, AND ERECTION SHALL BE IN ACCORDANCE WITH THE "AISC SPECIFICATION FOR STRUCTURAL STEEL BUILDINGS". WELDING SHALL CONFORM TO THE AISC CODES FOR ARC AND GAS WELDING IN BUILDING CONSTRUCTION AND SHALL BE 3/16" MINIMUM UNLESS OTHERWISE NOTED. WELDING SHALL BE BY AISC CERTIFIED WELDERS. PREQUALIFIED WELDING PROCEDURES ARE TO BE USED, UNLESS AISC QUALIFICATION IS SUBMITTED TO THE ARCHITECT/ENGINEER PRIOR TO FABRICATION.

INSTALLATION AND TIGHTENING OF ALL BOLTS SHALL BE IN ACCORDANCE WITH THE "SPECIFICATIONS FOR STRUCTURAL JOINTS USING ASTM A325 OR A490 BOLTS". UNLESS NOTED OTHERWISE BOLTS SHALL BE INSTALLED IN ALL HOLES OF THE CONNECTION AND BROUGHT TO A SNUG-TIGHT CONDITION. SNUG TIGHT IS DEFINED AS THE TIGHTNESS THAT EXISTS WHEN THE FLIES OF THE JOINT ARE IN FIRM CONTACT. THIS MAY BE ATTAINED BY A FEW IMPACTS OF AN IMPACT WRENCH OR THE FULL EFFORT OF A MAN USING AN ORDINARY SPUD WRENCH.

COLD-FORMED STEEL:

THE DESIGN, INSTALLATION AND CONSTRUCTION OF COLD-FORMED CARBON OR LOW-ALLOY STEEL, STRUCTURAL AND NON-STRUCTURAL FRAMING, SHALL BE IN ACCORDANCE WITH THE MOST CURRENT STANDARDS FOR COLD-FORMED STEEL FRAMING - GENERAL PROVISIONS, AISI.

FASTENING OF COMPONENTS SHALL BE WITH #0 SELF DRILLING SCREWS UNLESS NOTED OTHERWISE ON THE DRAWINGS. PENETRATION OF ALL SCREWS THROUGH JOINED MATERIALS SHOULD NOT BE LESS THAN 3 EXPOSED THREADS, INSTALLED AND TIGHTENED IN ACCORDANCE WITH THE SCREW MANUFACTURER'S RECOMMENDATIONS. ALL SCREWS EXPOSED TO WEATHER SHALL BE GALVANIZED. ANY SCREWS PENETRATING THE ROOF DECK SHALL BE INSTALLED WITH A NEOPRENE WASHER.

ALL FRAMING EXPOSED TO WEATHER SHALL BE MINIMUM 'G30' GALVANIZED.

FLASHING AND WATERPROOFING:

ALL FLASHING AND WATERPROOFING SHALL BE BY OTHERS UNLESS NOTED OTHERWISE ON THE PLANS.

INSPECTION:

SPECIAL INSPECTIONS: IN ACCORDANCE WITH SECTION 1704 OF THE IBC AND APPLICABLE SECTIONS OF THE PROJECT SPECIFICATIONS. SPECIAL INSPECTIONS ARE TO BE PERFORMED BY AN INDEPENDENT TESTING LABORATORY EMPLOYED BY THE OWNER FOR THE AREAS INDICATED IN THE SPECIAL INSPECTION PROGRAM.

THE CONTRACTOR AND SPECIAL INSPECTOR SHALL NOTIFY THE ENGINEER OF RECORD OF ANY ITEM NOT COMPLYING WITH THE PROJECT SPECIFICATIONS AND/OR APPLICABLE CODES BEFORE PROCEEDING WITH ANY WORK INVOLVING THAT ITEM. THE ENGINEER OF RECORD WILL REVIEW THE ITEM AND DETERMINE ACCEPTABILITY. IF WORK INVOLVING THAT ITEM PROCEEDS WITHOUT THE APPROVAL OF THE ENGINEER OF RECORD THEN THE WORK WILL BE CONSIDERED NON-COMPLIANT.

SPECIAL INSPECTION PROGRAM			
ESTABLISHED PER 2009 IBC AS AMENDED BY 2010 OSSC SECTION 110 & CHAPTER 17			
ITEM	CONTINUOUS	PERIODIC	COMMENTS
GENERAL STRUCTURAL INSPECTIONS AS REQUIRED BY SECTION 109			
FOOTING AND FOUNDATION REINFORCEMENT			BY BUILDING OFFICIAL
FINAL INSPECTION			BY BUILDING OFFICIAL
STEEL			
MATERIAL VERIFICATION OF HIGH STRENGTH BOLTS, NUTS, AND WASHERS		X	REFERENCE APPLICABLE ASTM MATERIAL SPECIFICATIONS, AISC 360, SECTION A3.3
HIGH STRENGTH BOLTING		X	OSSC 1704.3.3, AISC 360 SECTION M2.5 (CONTINUOUS INSPECTION FOR SLIP CRITICAL)
MATERIAL VERIFICATION OF STRUCTURAL STEEL		X	AISC 360 SECTION M5.5, ASTM A 6, ASTM A 588
COMPLIANCE OF STEEL FRAME JOINTS TO CONSTRUCTION DOCUMENT DETAILS		X	OSSC 1704.3.2
WELDING: STRUCTURAL STEEL			
MATERIAL VERIFICATION OF WELD FILLER MATERIALS			AISC 360, SECTION A3.5, AWS A5 DOCUMENTS
COMPLETE AND PARTIAL PENETRATION	X		
MULTIPASS FILLET WELDS	X		
SINGLEPASS FILLETS > 5/16"	X		OSSC 1704.3.1, AWS D1.1
SINGLEPASS FILLETS ≤ 5/16"		X	
CONCRETE			
REINFORCING SIZE AND PLACEMENT		X	OSSC 1913.4, ACI 318: 5.5, 7.1-7.7
CONCRETE PLACEMENT	X		OSSC 1913.6-8, ACI 318: 5.9, 5.10
MAINTENANCE OF SPECIFIED CURING TEMPERATURES AND TECHNIQUES		X	OSSC 1913.9, ACI 318: 5.11-5.13
INSPECT FORMWORK FOR SHAPE, LOCATION AND DIMENSIONS OF THE CONCRETE MEMBER BEING FORMED		X	ACI 318: 6.1.1

NOTE: THE SPECIAL INSPECTION PROGRAM FOR SOILS AND ANY PILE OR PER FOUNDATIONS IS PER THE GEOTECHNICAL SPECIAL. REFERENCE OSSC 1704.7, 1704.8, AND 1704.9.

DEFINITIONS:

- A. CONTINUOUS INSPECTION MEANS THAT THE SPECIAL INSPECTOR IS ON SITE AT ALL TIMES OBSERVING THE WORK REQUIRING SPECIAL INSPECTION.
- B. PERIODIC INSPECTION MEANS THAT THE SPECIAL INSPECTOR IS ON SITE AT TIME INTERVALS NECESSARY TO CONFIRM THAT THE WORK REQUIRING SPECIAL INSPECTION IS IN CONFORMANCE WITH APPROVED PERMIT PLANS AND SPECIFICATIONS.

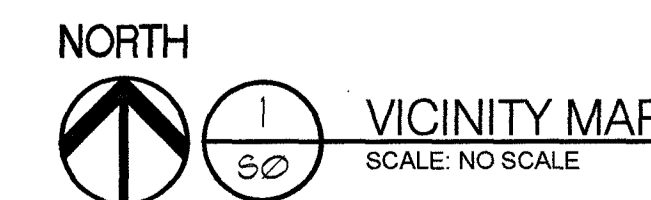
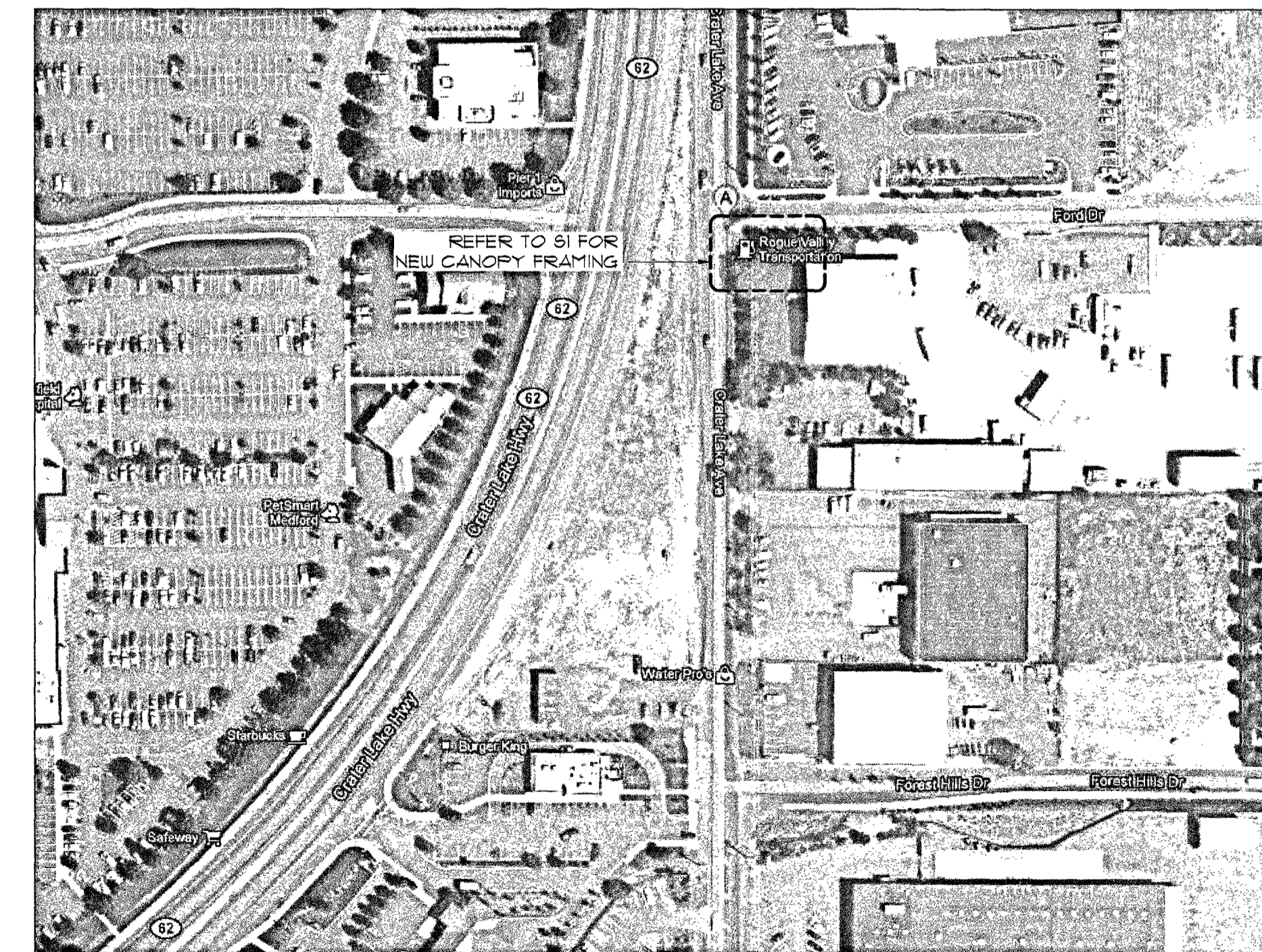

TMR
T.M. RIPPEY
CONSULTING ENGINEERS

901 NORTHWEST E
GRANTS PASS, OR 97526
Phone: 541-476-1387 Fax: 541-474-2528
CCB #40432

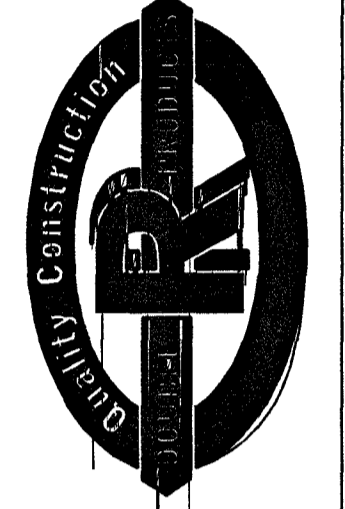

CLIENT:
RVTD

PROJECT:
ROGUE VALLEY TRANSIT DISTRICT
3200 CRATER LAKE AVE.
MEDFORD, OR 97504

GENERAL NOTES

DATE: 09-22-11

JOB: 11319

SHEET
50
OF 4

REVISION: 10-07-11
COLUMN RELOCATION

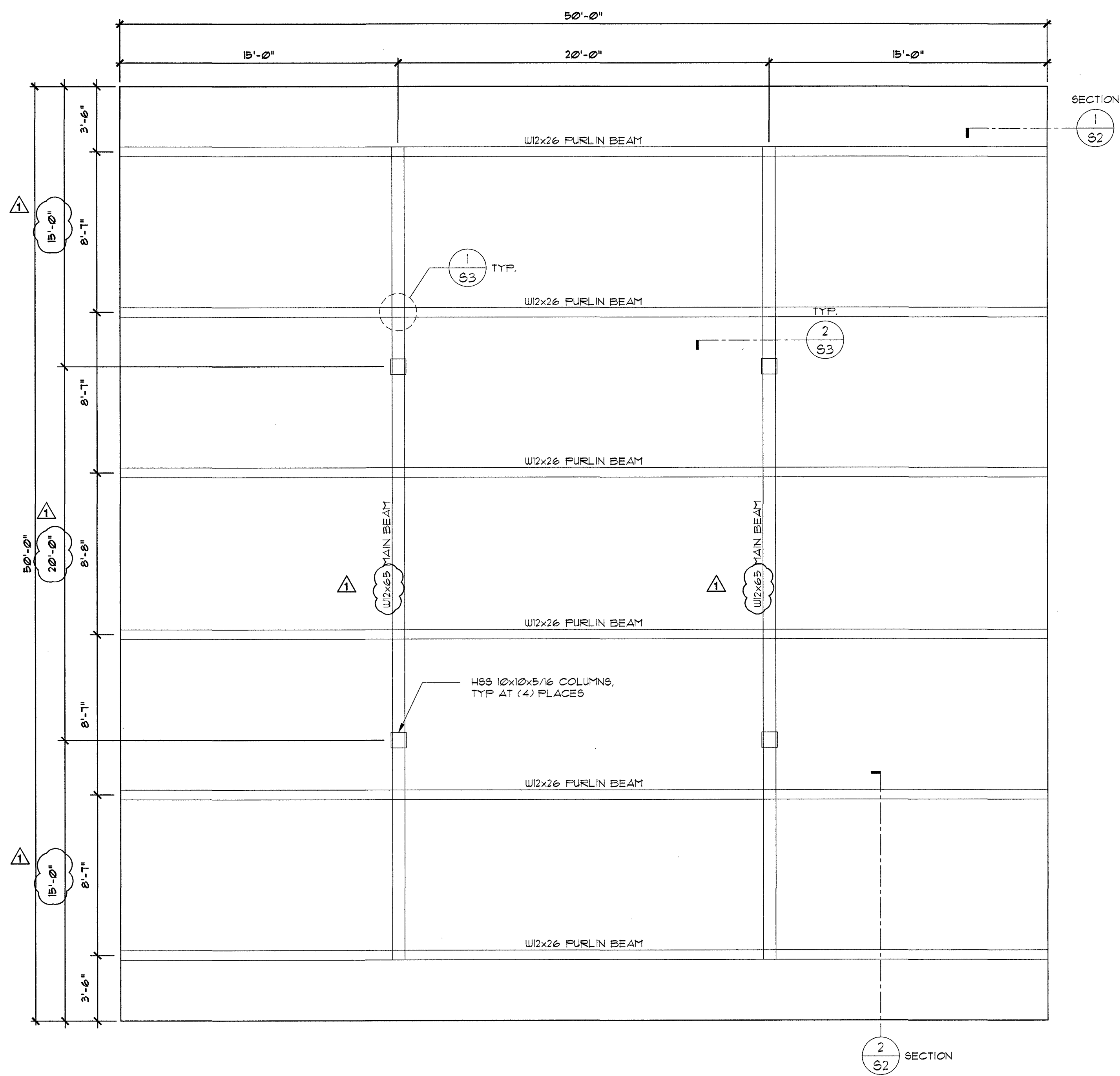

1 CANOPY STEEL
 S1 SCALE: 1/4" = 1'-0"

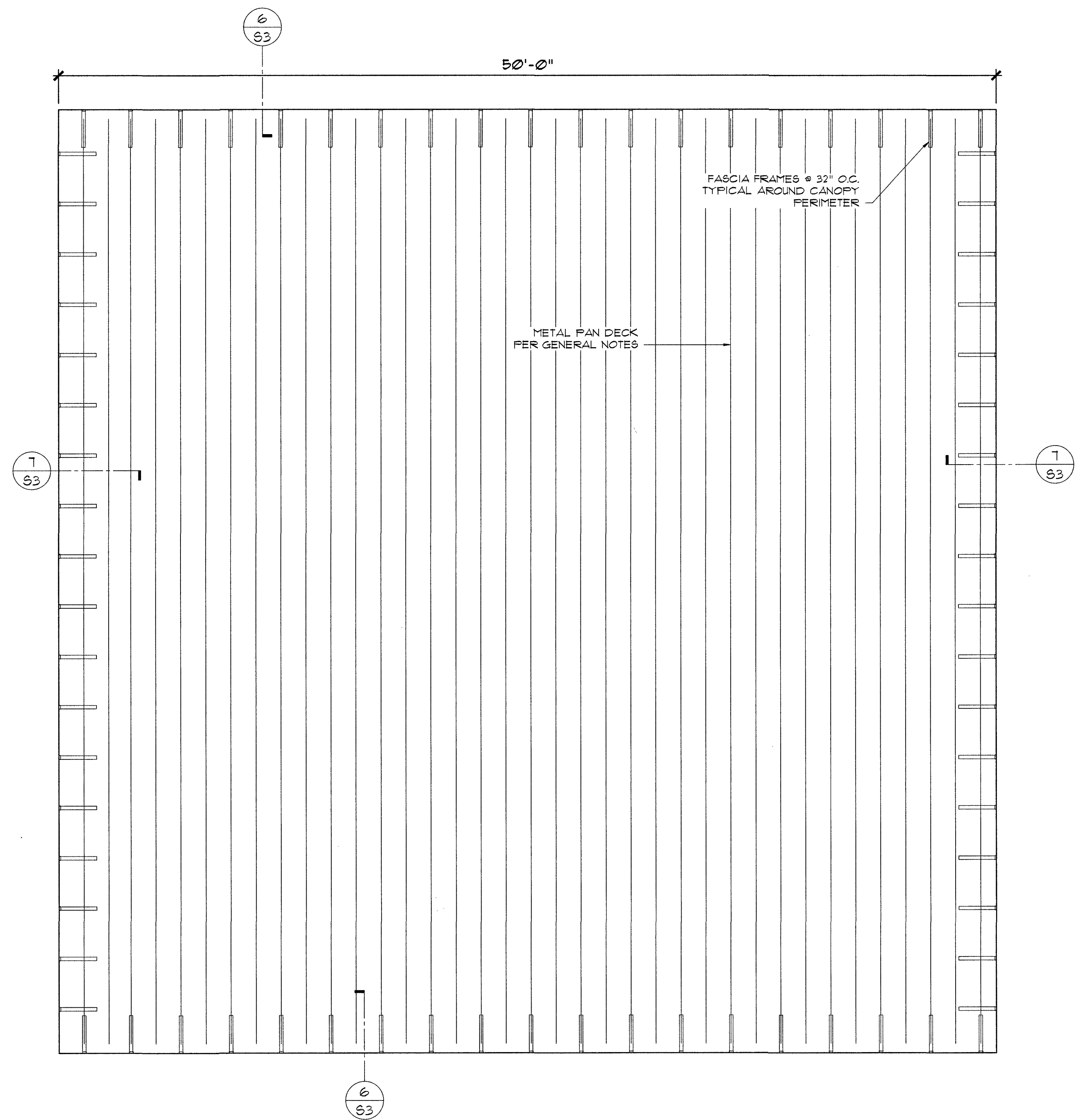

2 CANOPY ROOF
 S1 SCALE: 1/4" = 1'-0"

760 SW Bonded, Suite 100
 Tigard, Oregon 97223
 Phone: 541-474-2528
 Fax: 541-474-2528

TMR
 T.M. RIPPEY
 CONSULTING ENGINEERS

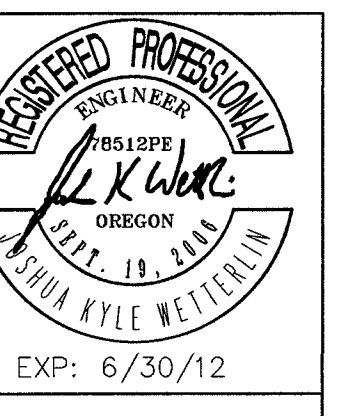

901 NORTHWEST E
 GRANTS PASS, OR 97526
 Phone: 541-476-1387 Fax: 541-474-2528
 CCB #40432

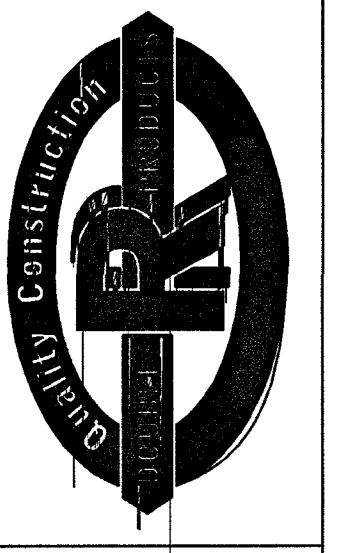

CLIENT:
 RVID

PROJECT:
 ROGUE VALLEY TRANSIT DISTRICT
 3200 CRATER LAKE AVE.
 MEDFORD, OR 97054

CANOPY
 PLAN

DATE: 09-22-11

JOB: 11319

SHEET

S1

OF 4

REVISION: 10-07-11
 COLUMN RELOCATION

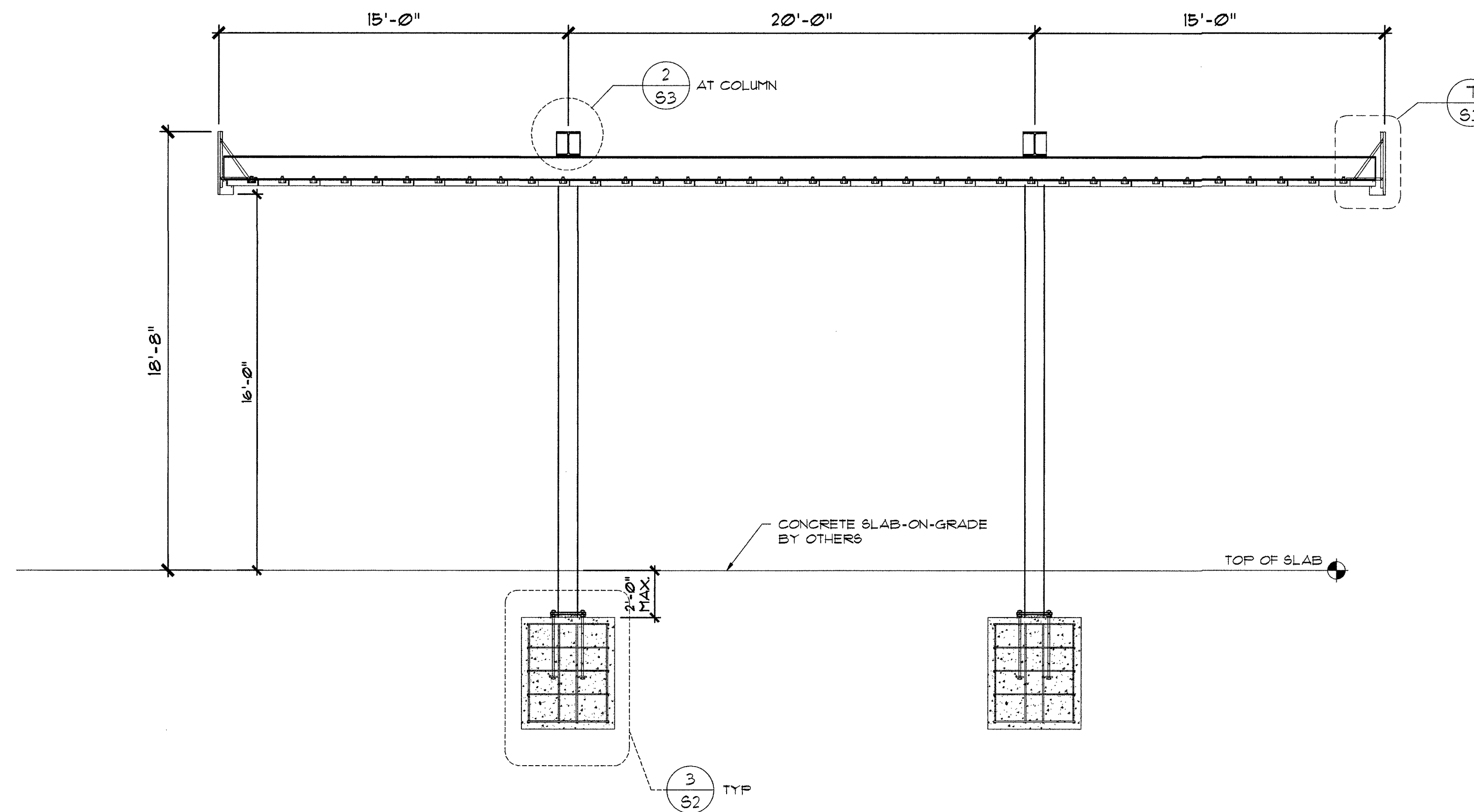

1 SECTION
SCALE: 1/4" = 1'-0"

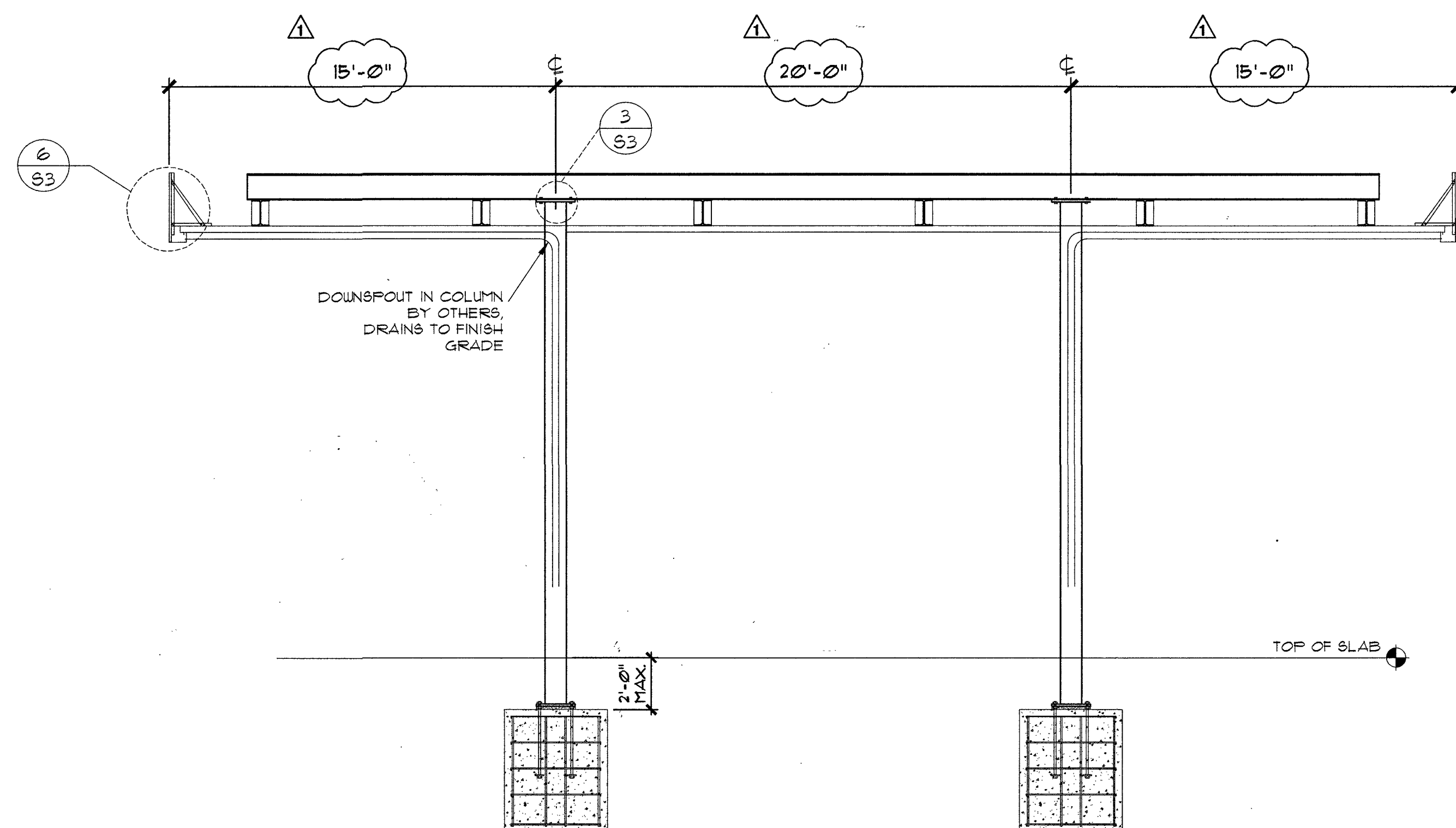

2 SECTION
SCALE: 1/4" = 1'-0"

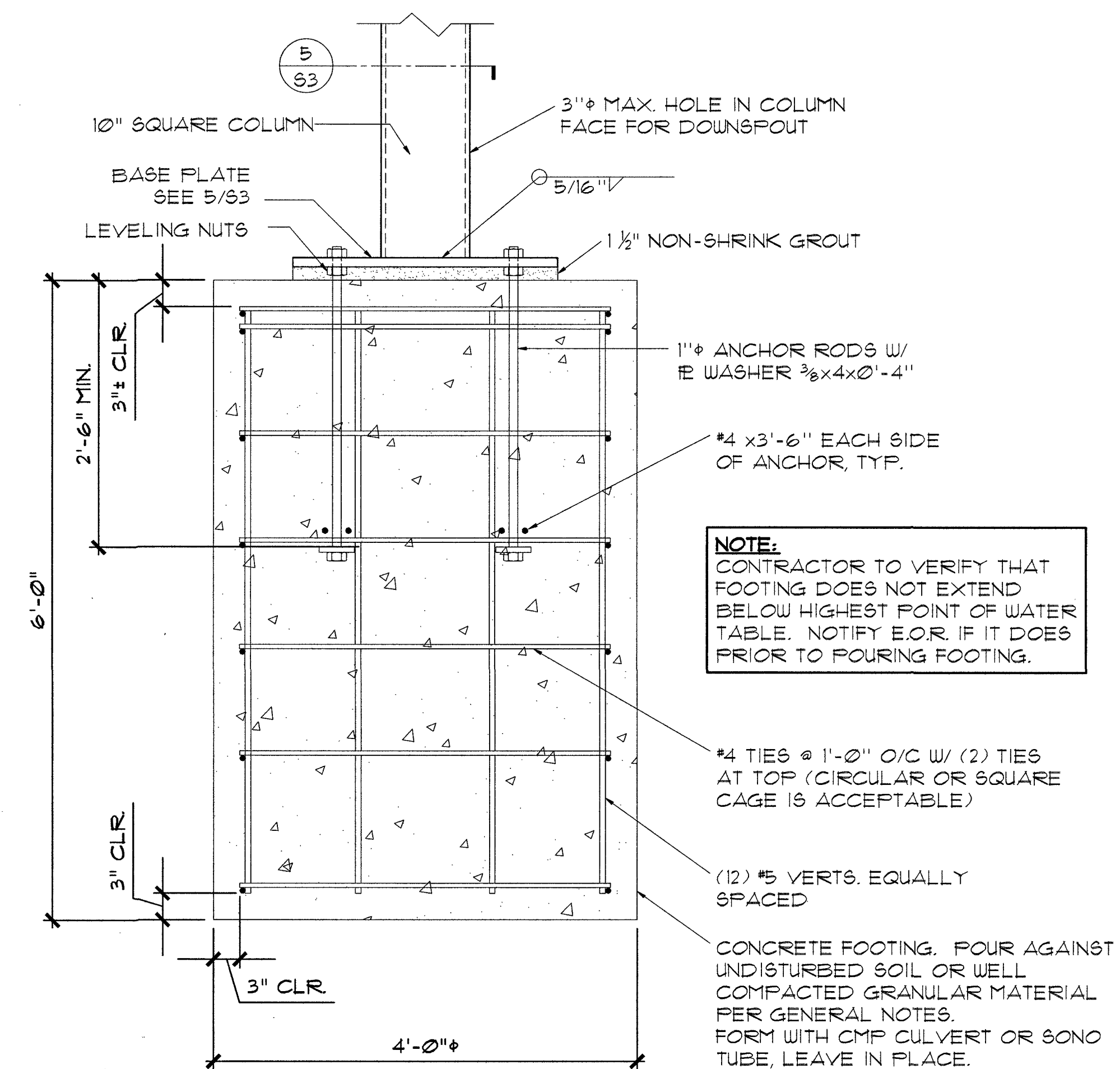

3 FOOTING
SCALE: 1" = 1'-0"

T.M. RIPPEY
CONSULTING ENGINEERS
7650 SW Hayward, Suite 100
Tigard, Oregon 97223
Phone: 541-474-2528
Fax: 541-474-2528
Per: 630-443-2700



901 NORTHWESTE
GRANTS PASS, OR 97526
Phone: 541-476-1387 Fax: 541-474-2528
CCB #40432

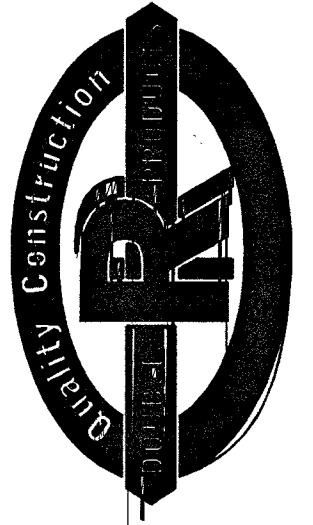

CLIENT:
RVTD

PROJECT:
ROGUE VALLEY TRANSIT DISTRICT
3200 CRATER LAKE AVE.
MEDFORD, OR 97054

CANOPY
SECTIONS

DATE: 09-22-11
JOB: 11319

SHEET
S2
OF 4

REVISION: 10-07-11
COLUMN RELOCATION

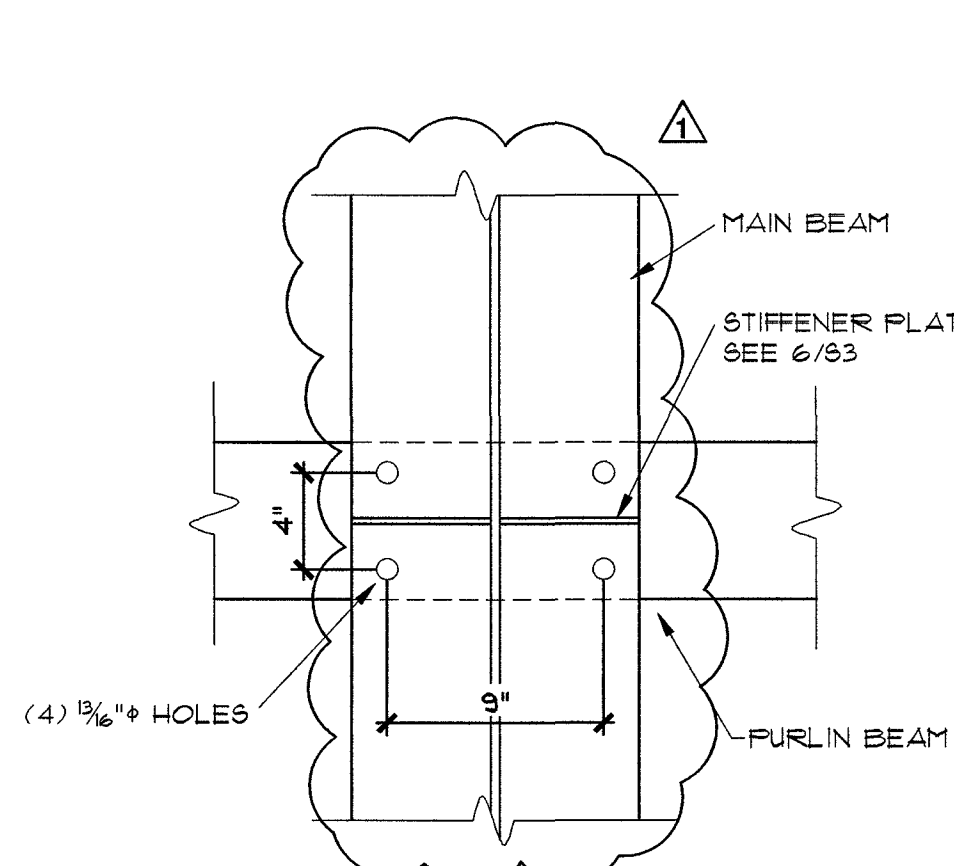

1 MAIN TO PURLIN
SCALE: 1-1/2" - 1'-0"

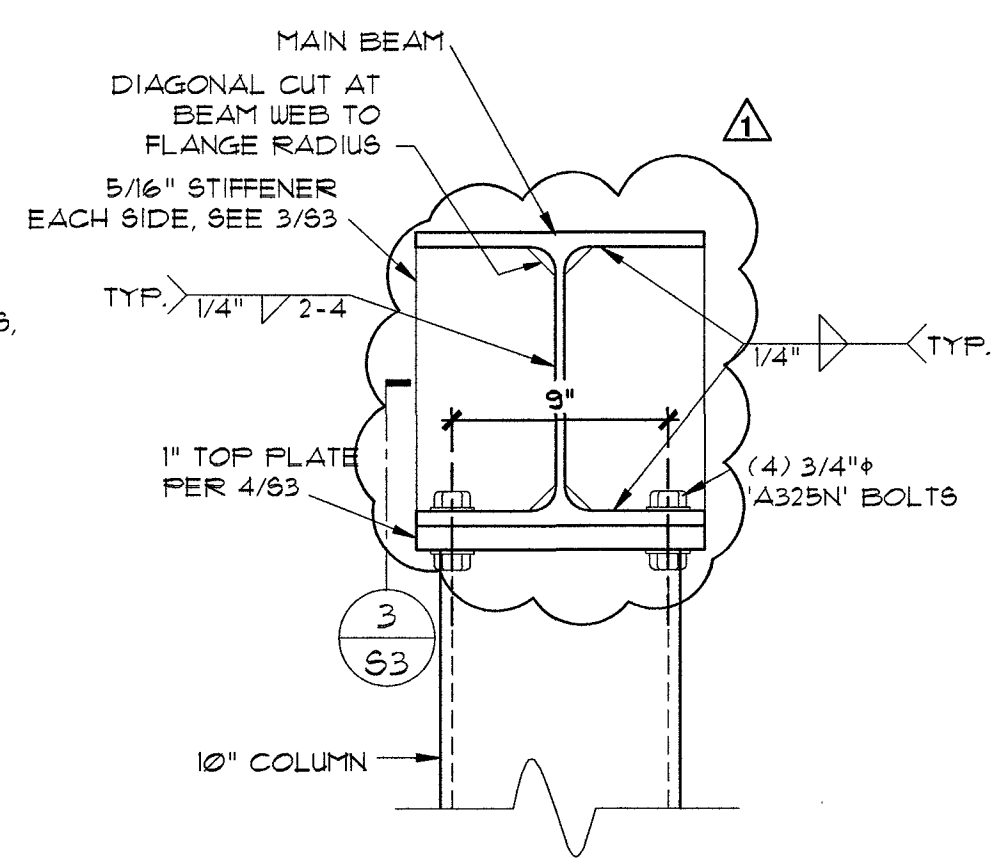

2 MAIN BEAM
SCALE: 1-1/2" - 1'-0"

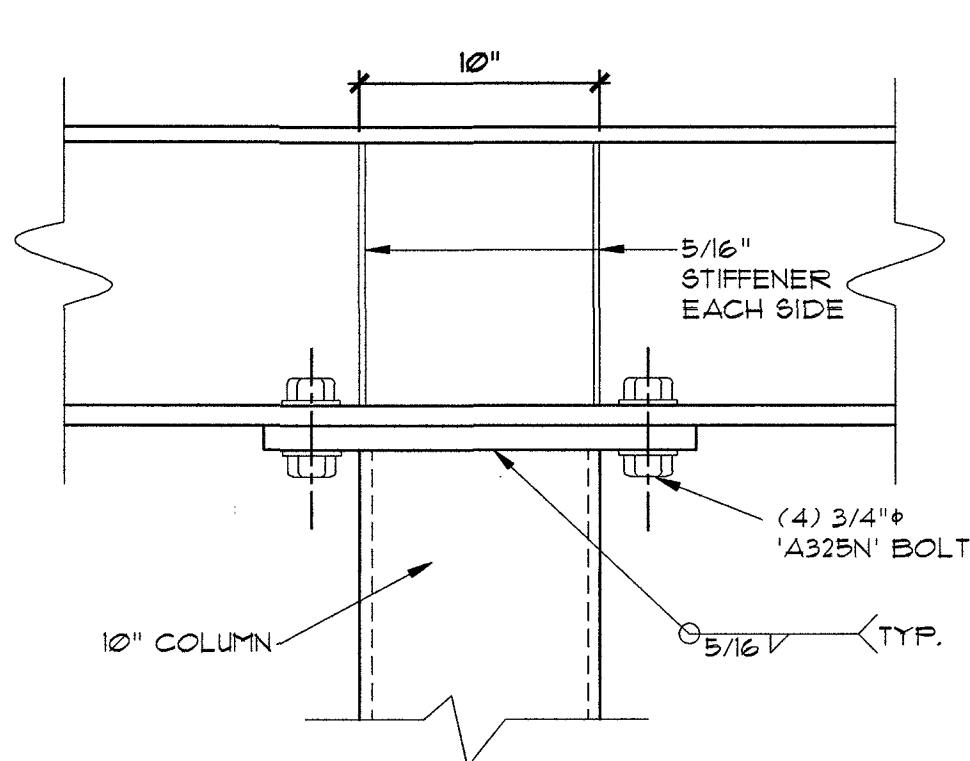

3 TOP PLATE
SCALE: 1-1/2" - 1'-0"

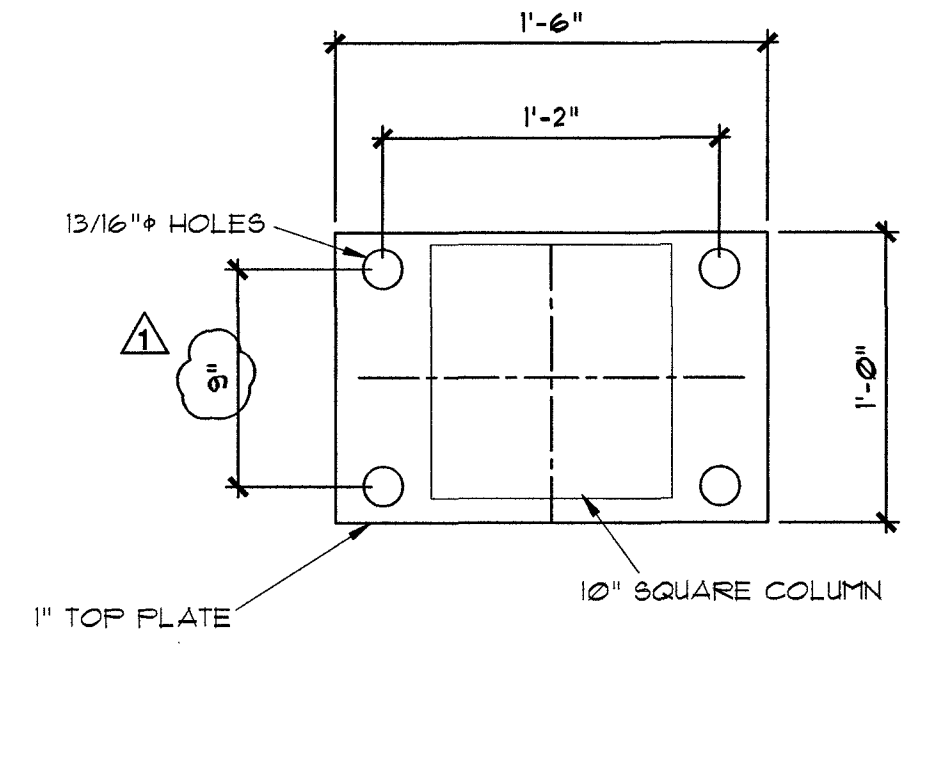

4 TOP PLATE
SCALE: 1-1/2" - 1'-0"

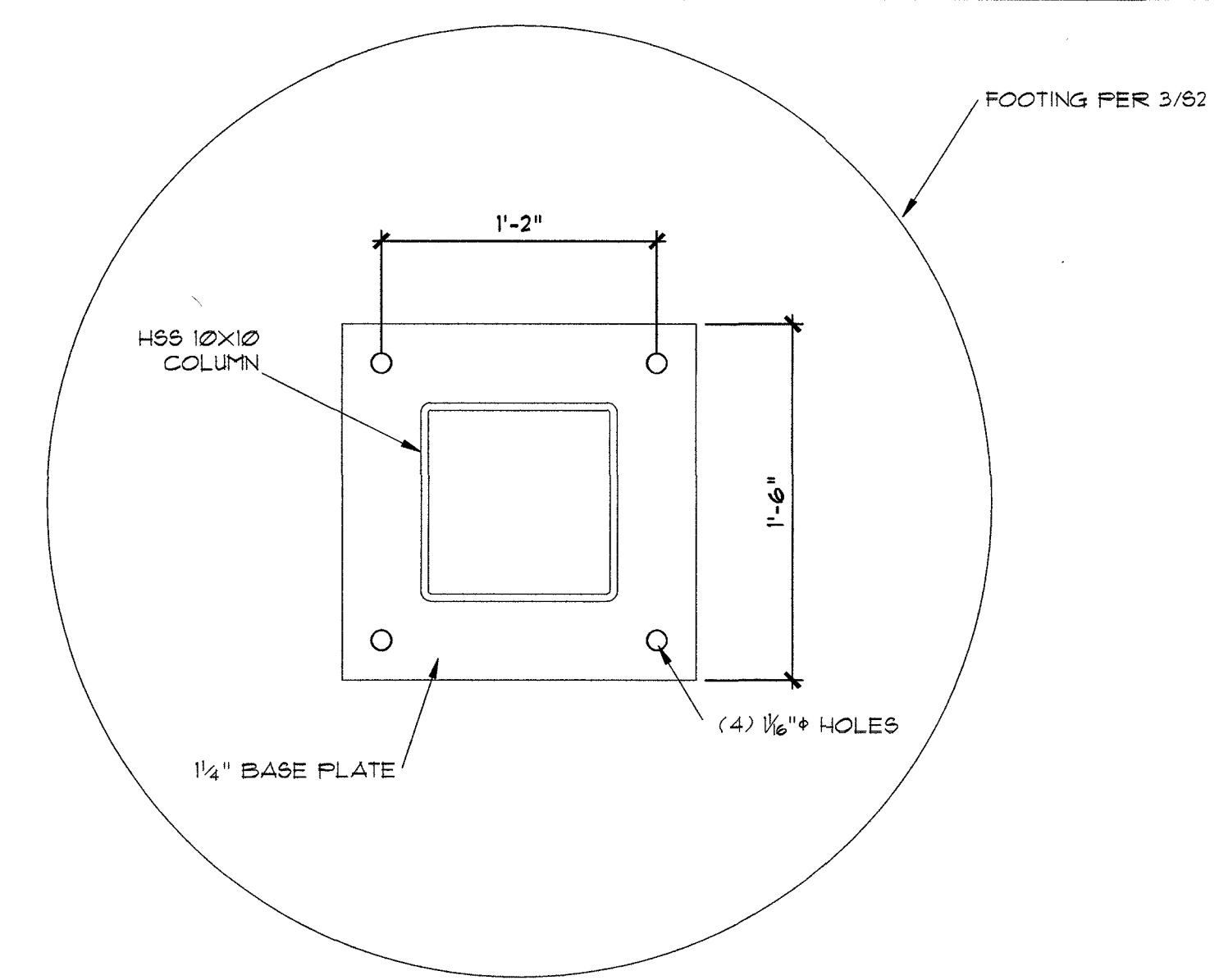

5 COLUMN BASE
SCALE: 1-1/2" - 1'-0"

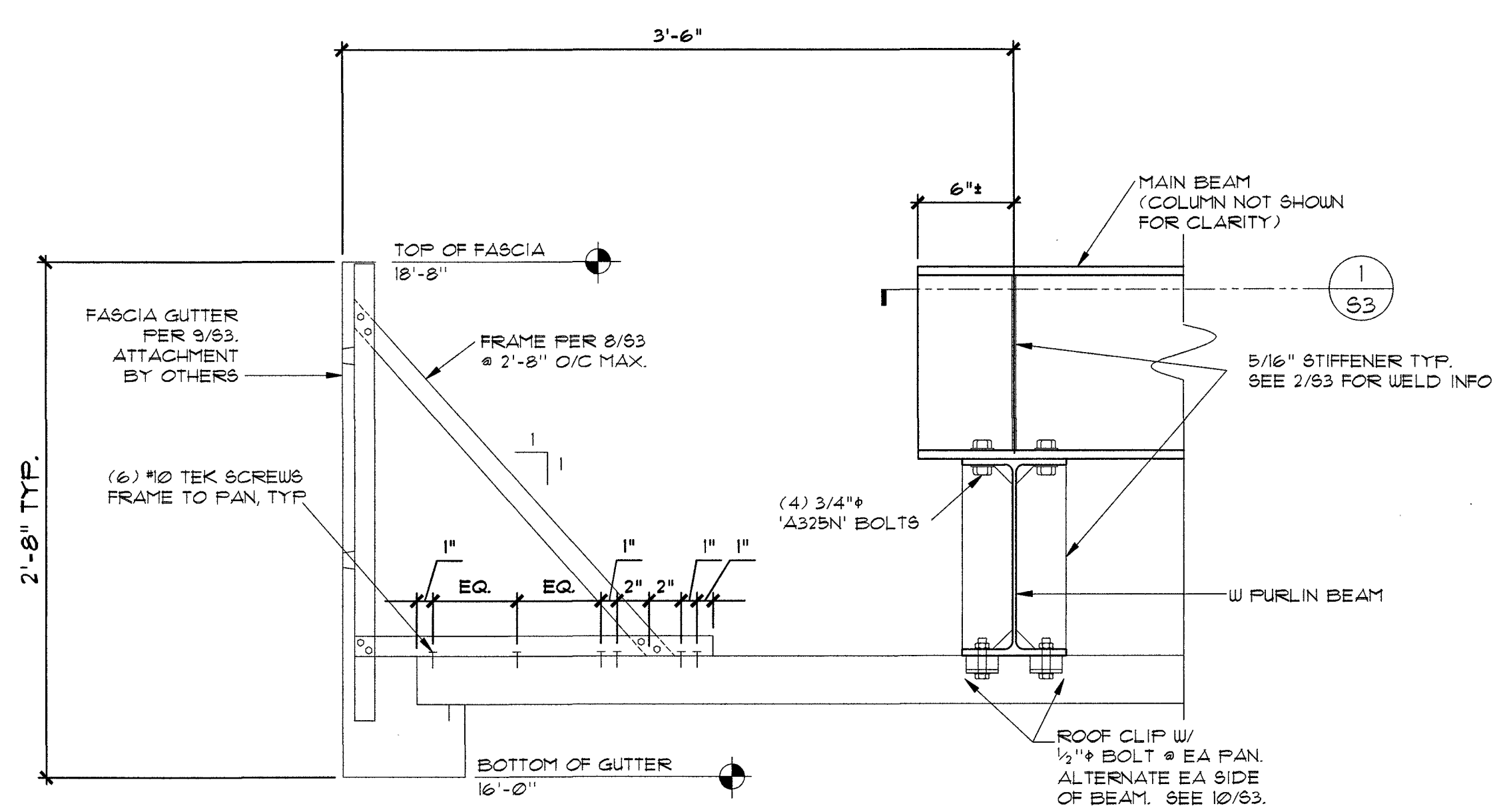

6 FASCIA / PURLIN
SCALE: 1-1/2" - 1'-0"

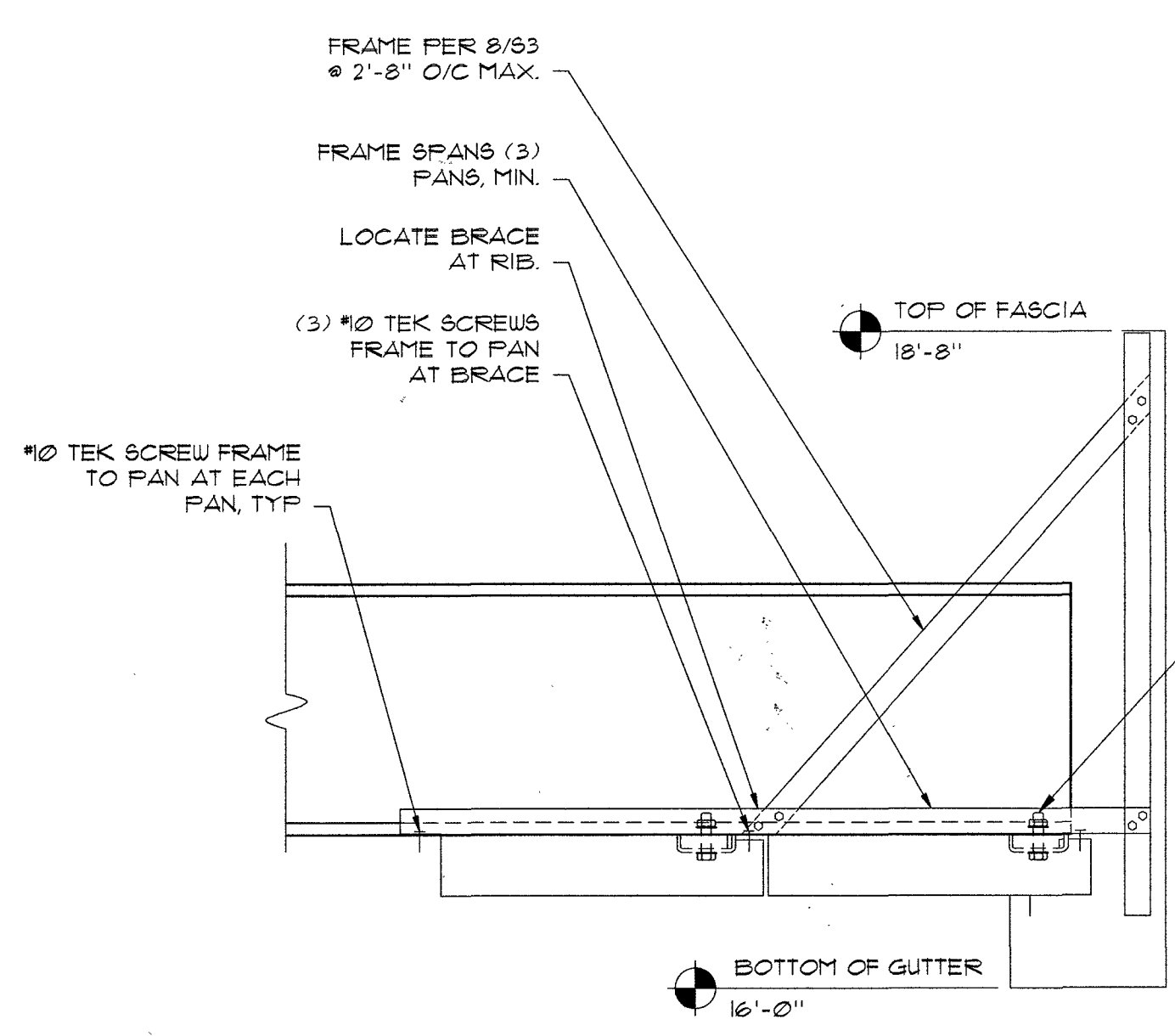

7 FASCIA / PURLIN
SCALE: 1-1/2" - 1'-0"

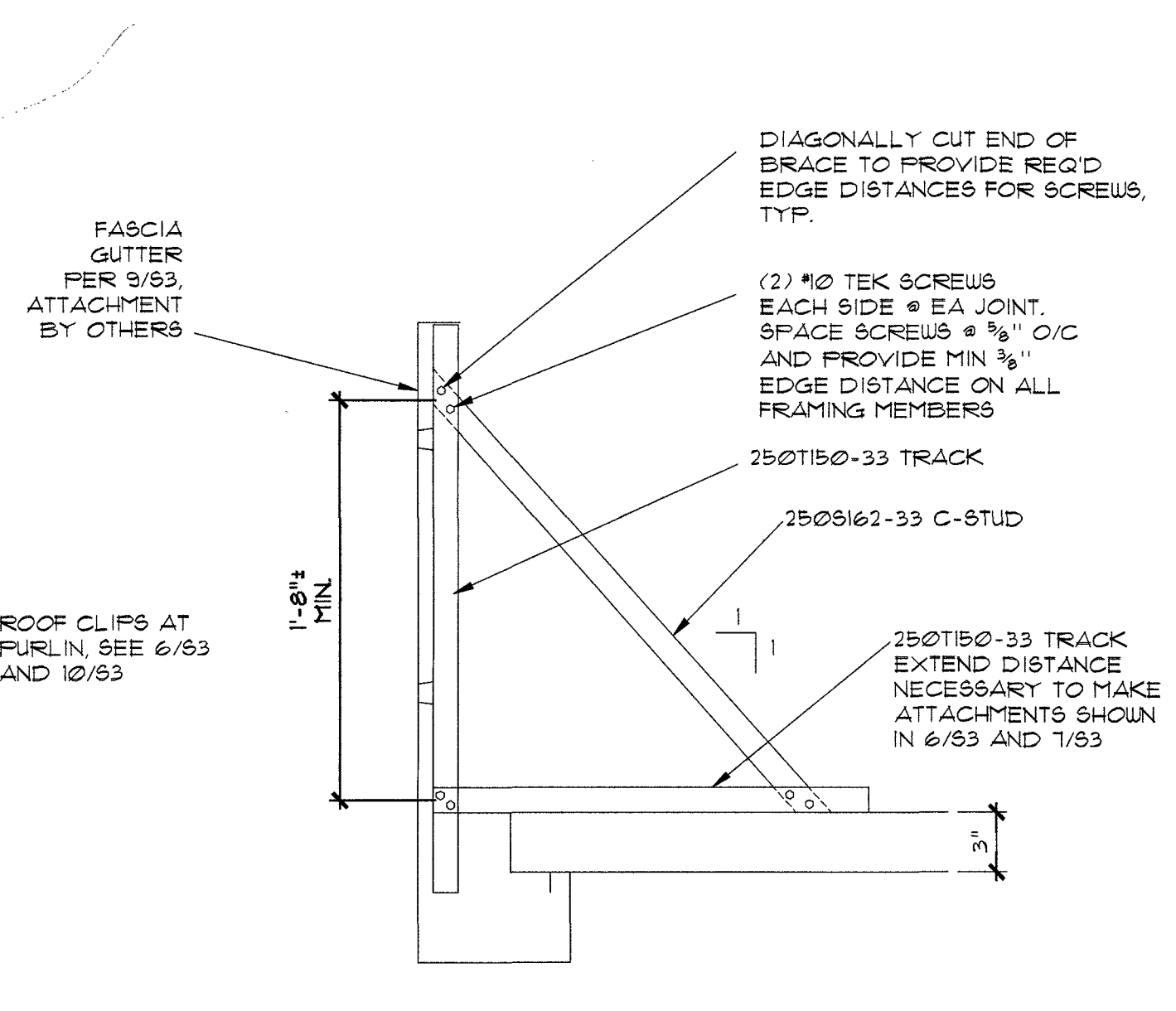

8 FRAME
SCALE: 1-1/2" - 1'-0"

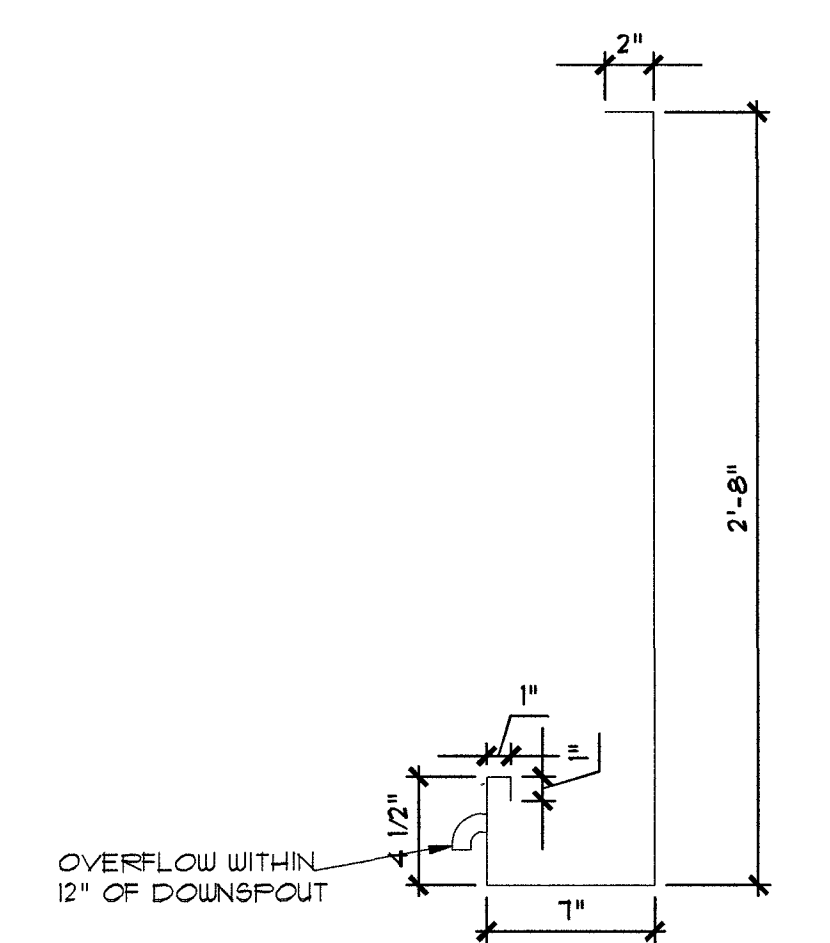

9 FASCIA GUTTER
SCALE: 1-1/2" - 1'-0"

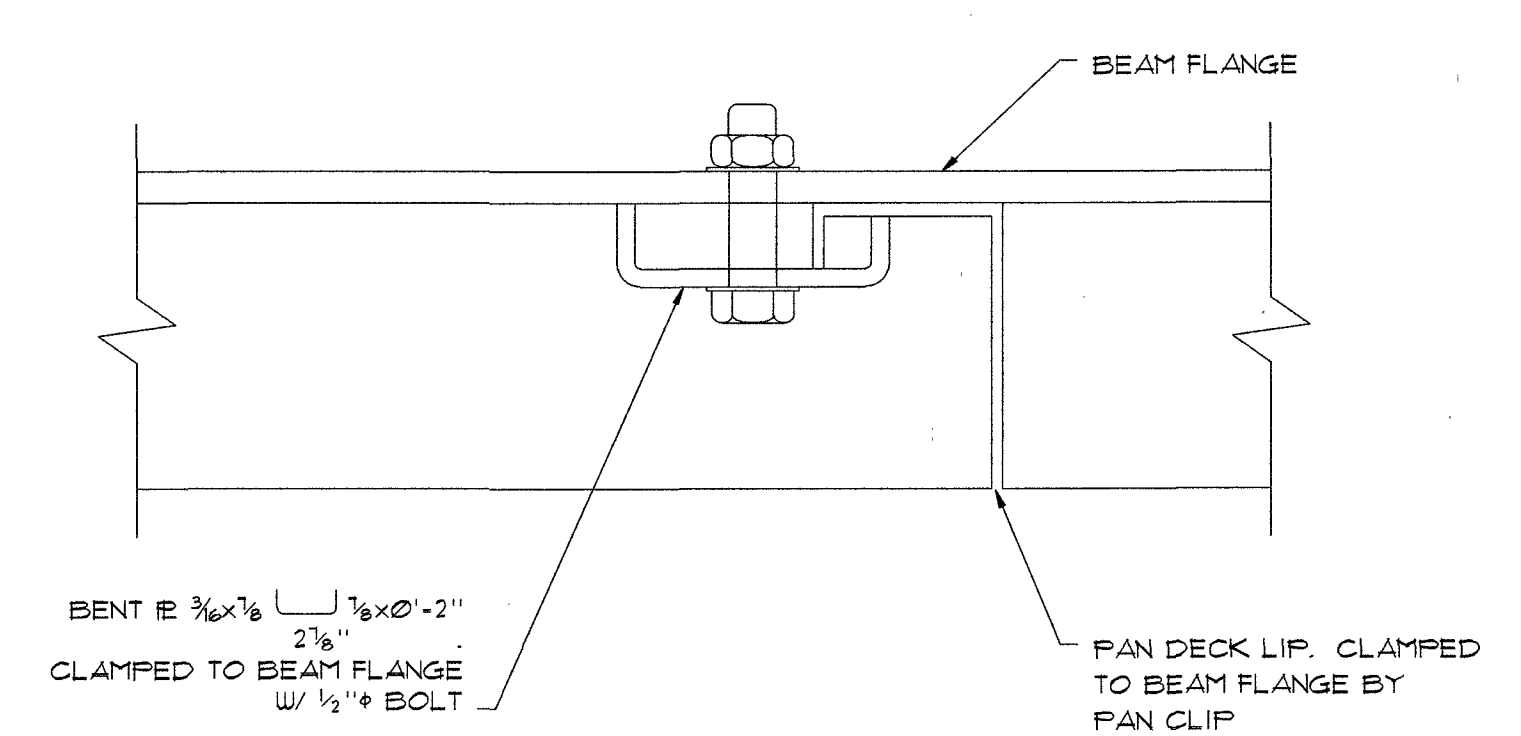

10 PAN CLIP
SCALE: 6" - 1'-0"

T.M.P. T.M. RIPPY CONSULTING ENGINEERS



901 NORTHWEST E GRANTS PASS, OR 97626
Phone: 541-476-1387 Fax: 541-474-2528
CCB #40432



CLIENT: RVTD

PROJECT: ROGUE VALLEY TRANSIT DISTRICT
3200 CRATER LAKE AVE.
MEDFORD, OR 97504

CANOPY DETAILS

DATE: 09-22-11

JOB: 11319

SHEET

S3

OF 4

REVISION: 10-07-11 COLUMN RELOCATION

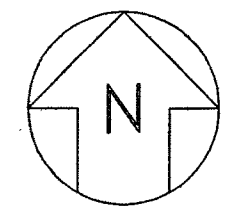
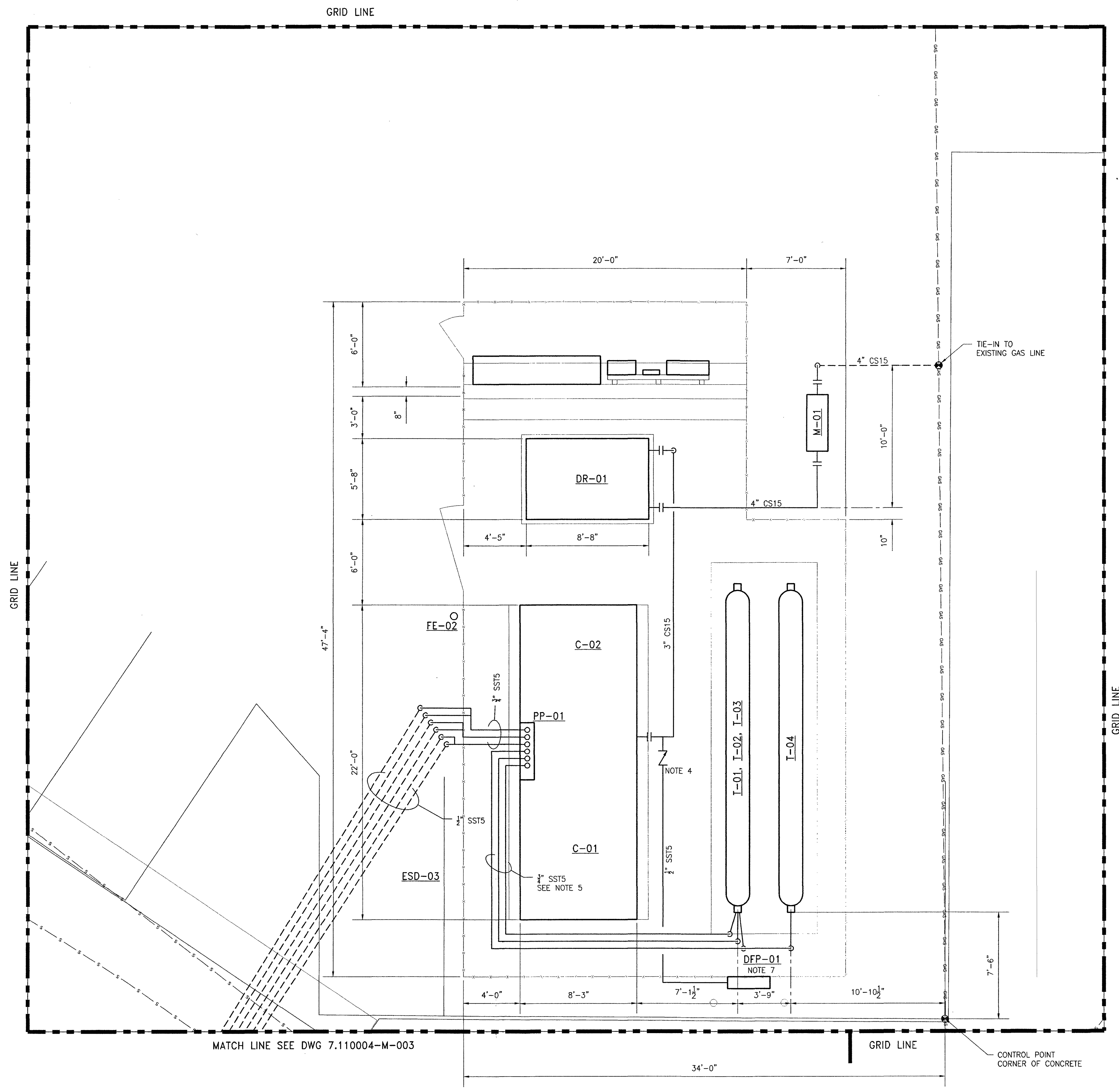

EQUIPMENT IDENTIFICATION:

EQUIP. NO.	DESCRIPTION
C-01	CNG COMPRESSOR SKID NO. 1
C-02	CNG COMPRESSOR SKID NO. 2
D-01	CNG DISPENSER NO. 1 (STANDARD)
D-02	CNG DISPENSER NO. 2 (BUS)
D-03	DIESEL DISPENSER
DFP-01	DEFUELING PANEL
DR-01	NATURAL GAS DRYER
ESD-01	EMERGENCY SHUTDOWN NO. 1 (ON DISPENSER)
ESD-02	EMERGENCY SHUTDOWN NO. 2 (ON DISPENSER)
ESD-03	EMERGENCY SHUTDOWN NO. 3
FE-01	FIRE EXTINGUISHER NO. 1 (TYPE 20 B/C)
FE-02	FIRE EXTINGUISHER NO. 2 (TYPE 20 B/C)
M-01	GAS METER
PP-01	PRIORITY PANEL
T-01	CNG STORAGE TANK NO. 1 (LOW PRESSURE)
T-02	CNG STORAGE TANK NO. 2 (MEDIUM PRESSURE)
T-03	CNG STORAGE TANK NO. 3 (HIGH PRESSURE)
T-04	CNG STORAGE TANK NO. 4 (LOW PRESSURE, EXISTING RELOCATED)

NOTES:

- PIPE LOCATIONS ARE APPROXIMATE.
- ALL UNDERGROUND PIPE SHALL BE BURIED 2'-6" MINIMUM BELOW SURFACE.
- SEE DRAWING 7.110004-M-004 FOR PIPE SPECIFICATIONS.
- CHECK VALVE PROVIDED BY CONTRACTOR.
- SUPPORT DESIGN BY INSTALLER. MAINTAIN 7'-0" CLEARANCE ABOVE FINISH FLOOR. USE SWAGelok OR EQUAL TUBE SUPPORT SYSTEMS.
- FOR REFERENCE DRAWINGS SEE DWG. 7.110004-M-001.
- ADD 3'-0" TO POST LENGTH AND CONCRETE IN GROUND.

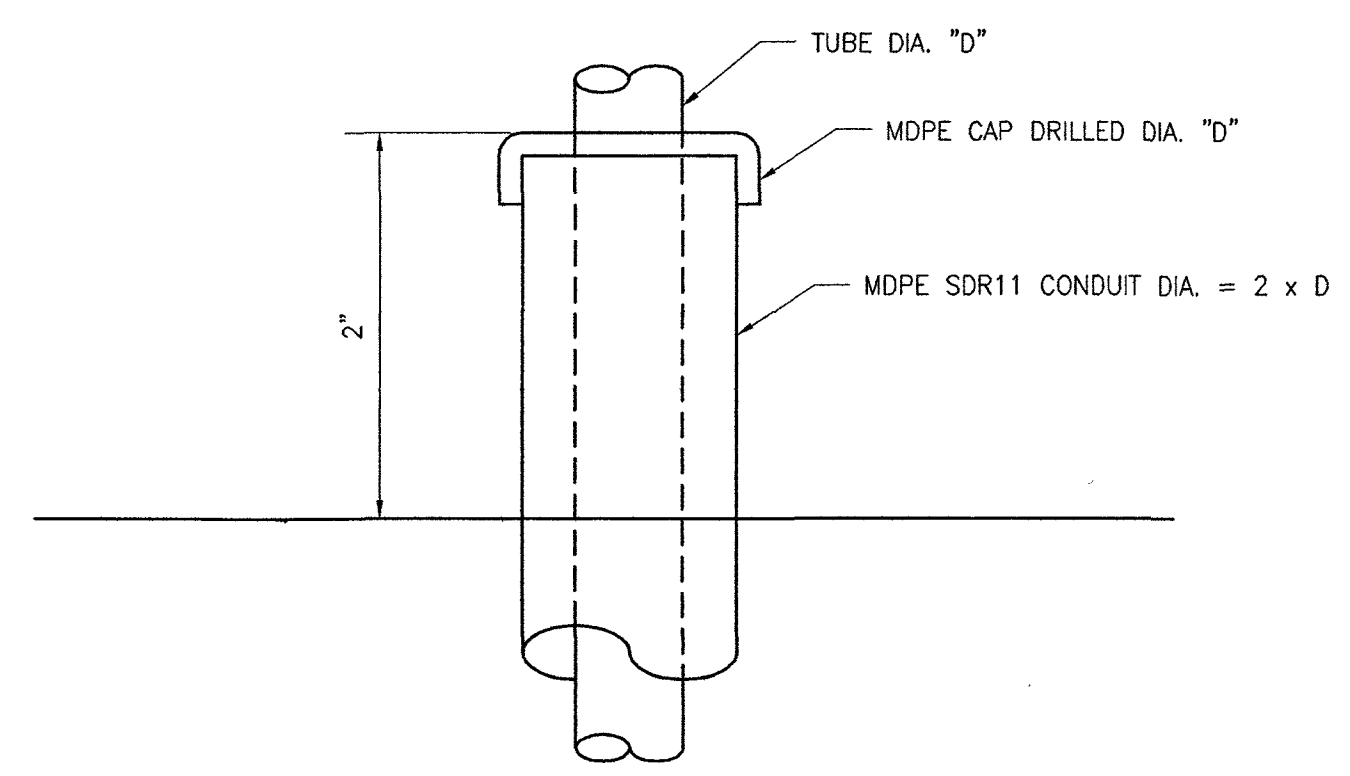

MECHANICAL REGISTERED PROFESSIONAL ENGINEER
 OREGON
 85705
All [Signature] 10/7/11
 RENEWS: 06/30/2012

APPROVED FOR CONSTRUCTION
 DATE: 10/7/11

HUNT, GUILLOT & ASSOCIATES, L.L.C.
 CONSULTING ENGINEERS AND PROJECT MANAGERS
 P.O. BOX 580 RUSTON, LA 71273

CONFIDENTIAL
 THESE DESIGNS AND DRAWINGS ARE THE EXCLUSIVE PROPERTY OF:
 HUNT, GUILLOT & ASSOCIATES, RUSTON, LA.
 NO COPY OR REPRODUCTION MAY BE MADE WITHOUT WRITTEN APPROVAL.

**ADROIT CONSTRUCTION
 Rvtd Cng Fueling Station
 EQUIPMENT LAYOUT**

DESIGNED BY	AW	8/8/11	CHECKED BY	SBS	9/14/11
DRAWN BY	JRE	8/8/11	APPROVED BY	RO	9/14/11
PLOT AT 1: 1	DATE: 8/8/11	HGA JOB NO: 7.110004	HGA ITEM NO:		
SCALE	1/4" = 1'-0"	DRAWING NUMBER	7.110004-M-002	REV.	0

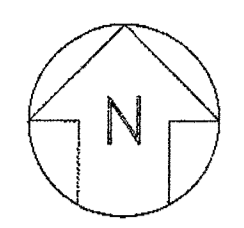
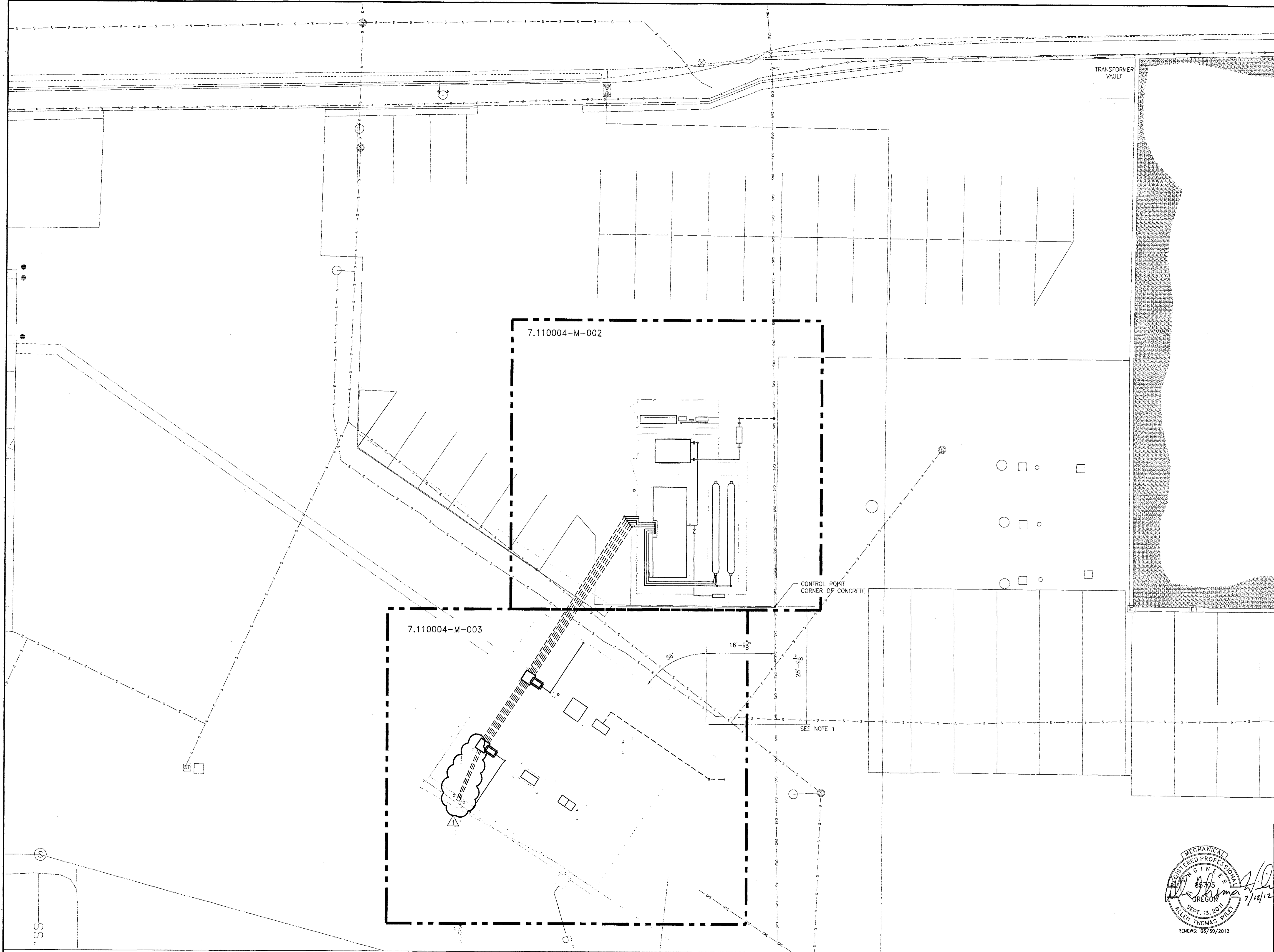

NOTES:

1. THESE DIMENSIONS ARE FOR REFERENCE ONLY, SEE DRAWING 7.110004-C-003 FOR GPS COORDINATES.

REFERENCE DRAWINGS:

- KRAUS GLOBAL:**
 HAM-3DCHG-P63C013S1S01 SHEET 1 OF 2
 HAM-3DCHG-P63C013S1S01 SHEET 2 OF 2
 DAM-3CHG-DAM-3CHG-P62C012S2S01 SHEET 1 OF 2
 DAM-3CHG-P62C012S2S01 SHEET 1 OF 2
 DAM-3CHG-P62C012S2S01 SHEET 1 OF 2
 HAM-3DCHG-P63C013S1S01 SHEET 1 OF 2
 2973.CHG-ROO SHEET 1 OF 2
 2973.CHG-ROO SHEET 2 OF 2
- KNOX WESTERN:**
 828727
 890263
 890264
 D000-3708
 D000-3281
 D000-3282 SHEET 1 OF 2
 D000-3282 SHEET 2 OF 2
- PSB:**
 NG1C1000F-G1
 NG1C1000F-P1
- HGA:**
 7.110004-M-002
 7.110004-M-003
 7.110004-M-004

APPROVED FOR CONSTRUCTION
 DATE: 7/19/12

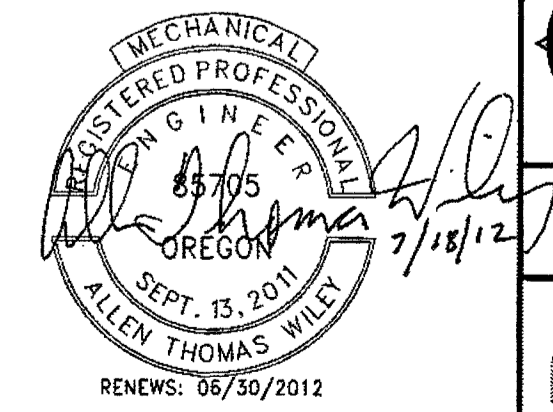

HUNT, GUILLOT & ASSOCIATES, L.L.C.
 CONSULTING ENGINEERS AND PROJECT MANAGERS
 P.O. BOX 580 RUSTON, LA 71273

MODEL NO:
 CONFIDENTIAL
 THESE DESIGNS AND DRAWINGS ARE THE EXCLUSIVE PROPERTY OF:
 HUNT, GUILLOT & ASSOCIATES, RUSTON, LA.
 NO COPY OR REPRODUCTION MAY BE MADE WITHOUT WRITTEN APPROVAL.

**ADROIT CONSTRUCTION
 Rvtd Cng Fueling Station
 SITE LAYOUT**

DESIGNED BY	AW	8/7/11	CHECKED BY	SBS	9/14/11
DRAWN BY	JRE	8/7/11	APPROVED BY	RO	9/14/11
PLOT AT 1: 1	DATE:	8/8/11	HGA JOB NO:	7.110004	HGA ITEM NO:
SCALE	DRAWING NUMBER		REV.		
3/32" = 1'-0"	7.110004-M-001		1		

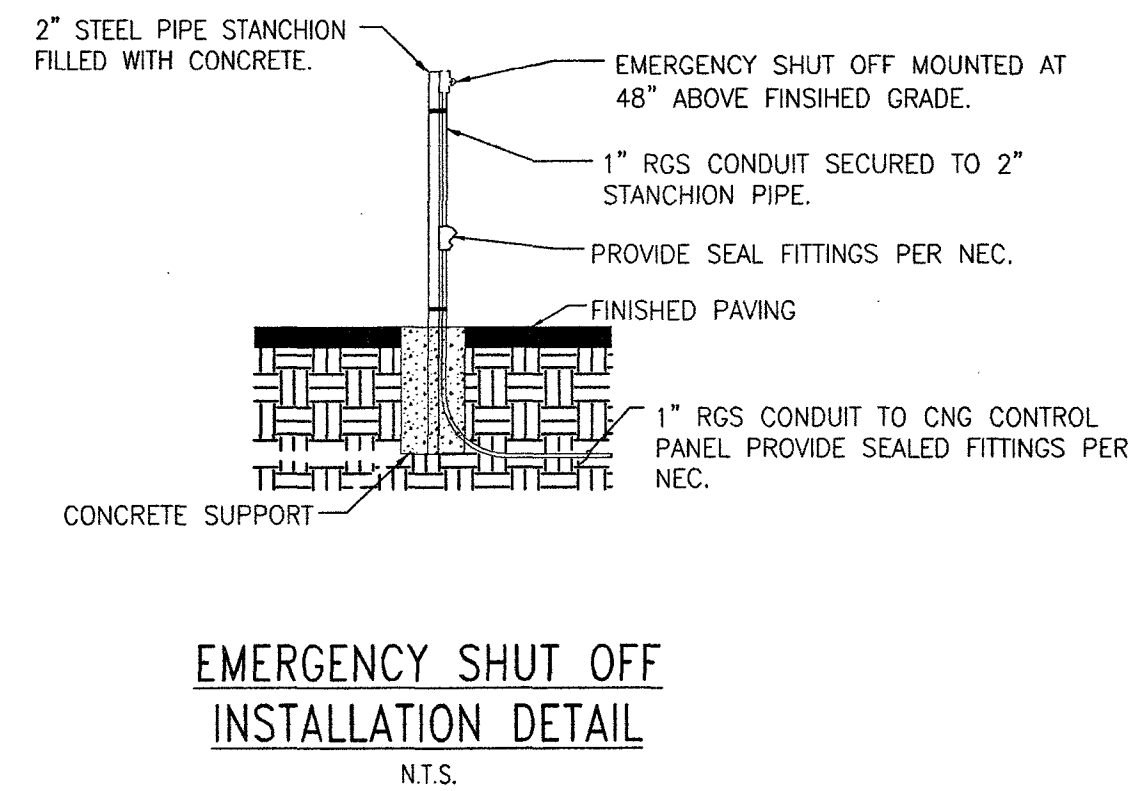
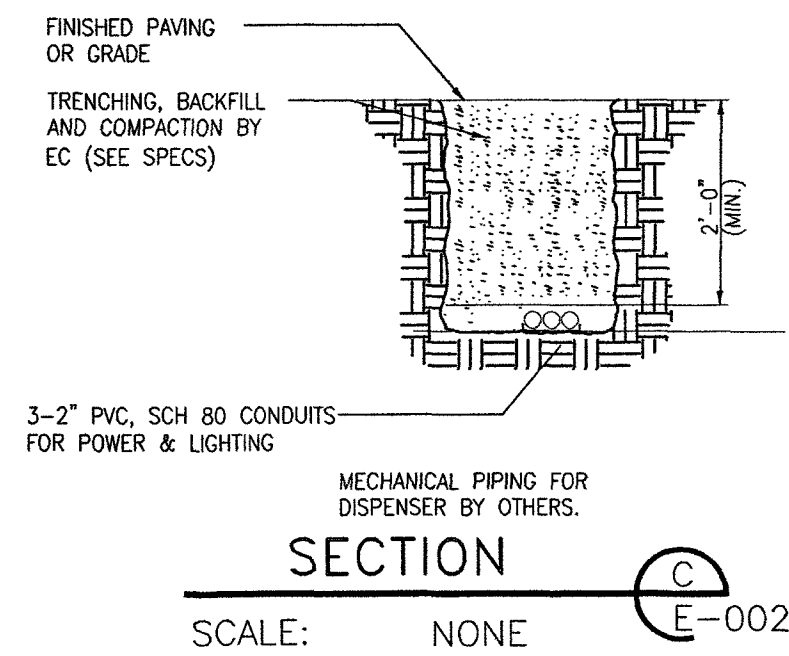
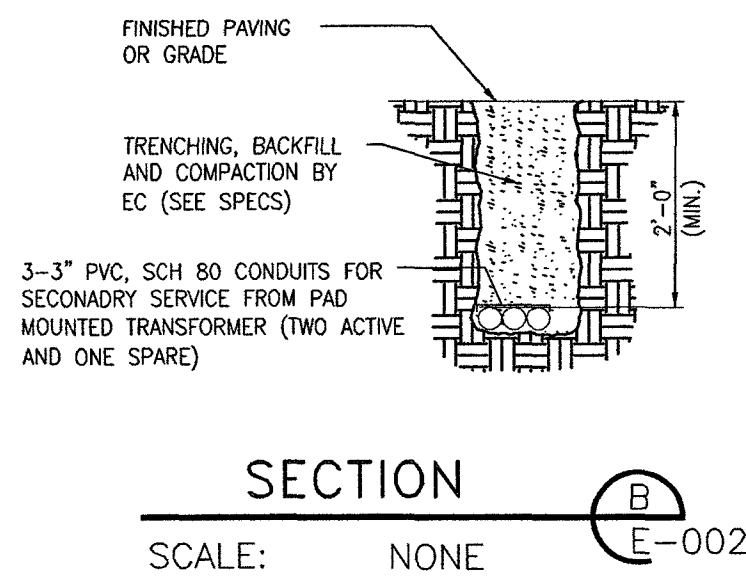
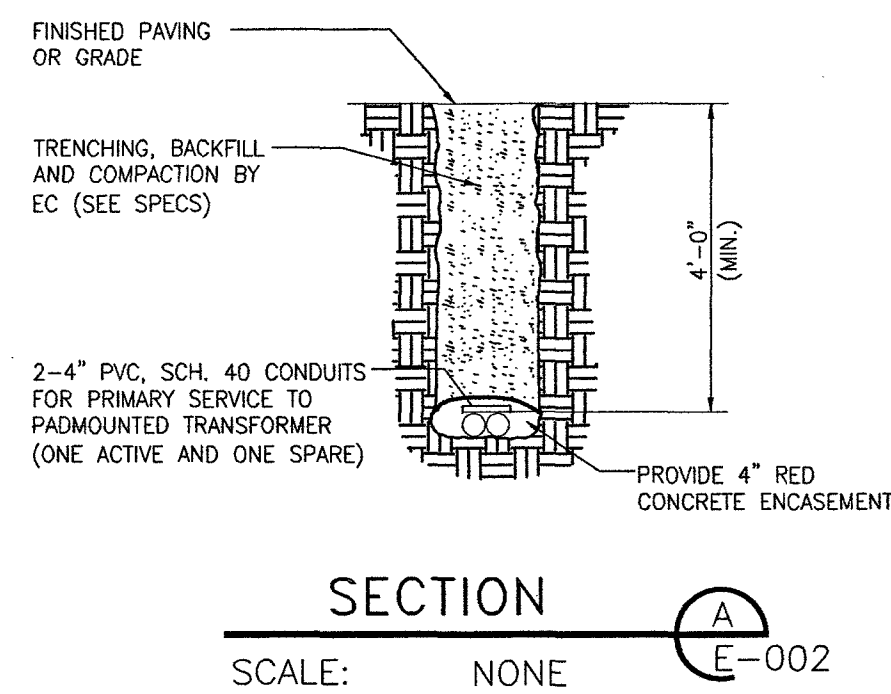

NOTES:

- ELECTRICAL CONTRACTOR SHALL RUN ALL NEW CIRCUITRY IN GRC CONDUIT OVERHEAD. ELECTRICAL CONTRACTOR SHALL SECURE ALL NEW OVERHEAD CONDUIT RUNS TO EXISTING STRUCTURE AS REQUIRED.

REFERENCE DRAWINGS:

- 7.110004-E-001 ADROIT CONSTRUCTION RVTD CNG FUELING STATION ONE-LINE/GENERAL NOTES
- 7.110004-E-002 ADROIT CONSTRUCTION RVTD CNG FUELING STATION ELECTRICAL SITE PLAN

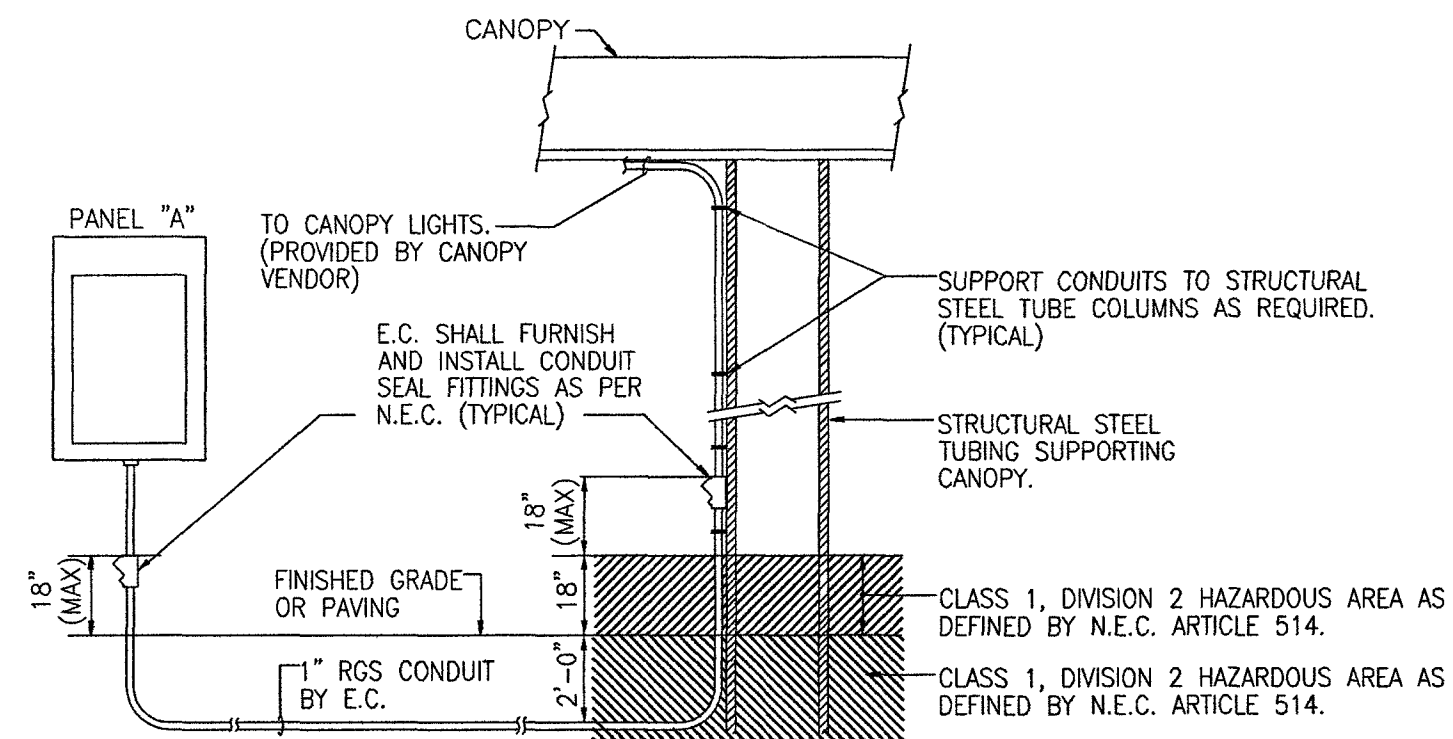

- NOTES:**
- ALL WIRING (CONDUCTORS) FOR THE FUEL CANOPY LIGHTS SHALL BE FURNISHED AND INSTALLED BY E.C.

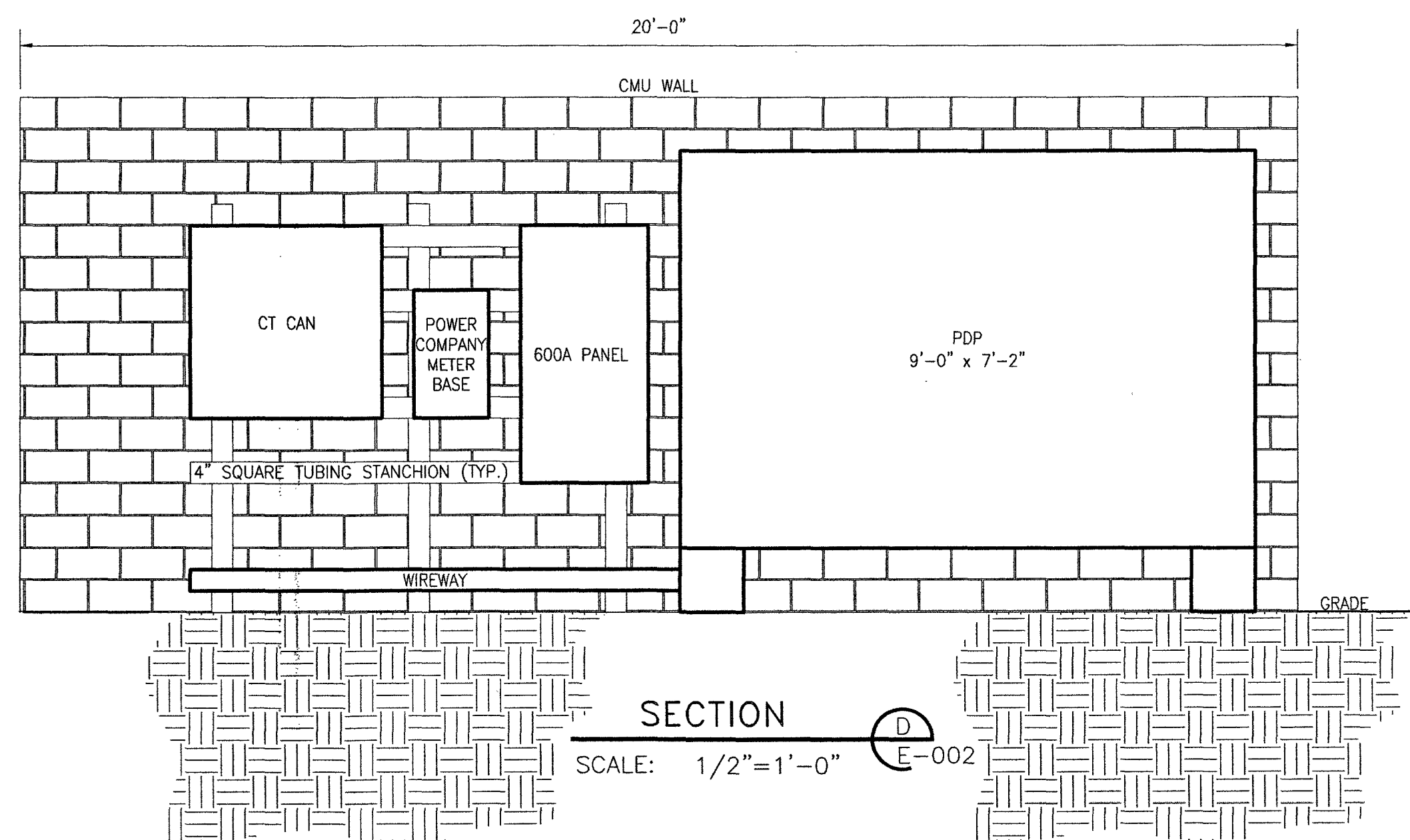
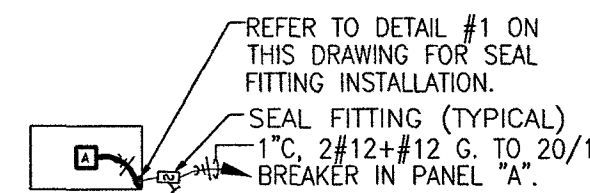

APPROVED FOR
CONSTRUCTION

DATE: 10/7/11



HUNT, GUILLOT & ASSOCIATES, L.L.C.
CONSULTING ENGINEERS AND PROJECT MANAGERS
P.O. BOX 580 RUSTON, LA 71273

CONFIDENTIAL
THESE DESIGNS AND DRAWINGS ARE THE EXCLUSIVE PROPERTY OF:
HUNT, GUILLOT & ASSOCIATES, RUSTON, LA.
NO COPY OR REPRODUCTION MAY BE MADE WITHOUT WRITTEN APPROVAL.

ADROIT CONSTRUCTION
RVTD CNG FUELING STATION
ELECTRICAL DETAILS

DESIGNED BY	JRE	9/6/11	CHECKED BY	DWG	9/14/11
DRAWN BY	JRE	9/6/11	APPROVED BY	RSO	9/14/11
PLOT AT 1: 1	DATE: 9/6/11	HGA JOB NO: 7.110004	HGA ITEM NO:		
SCALE	DRAWING NUMBER		REV.		
N.T.S.	7.110004-E-003		0		

SYMBOL SCHEDULE	
SYMBOL	DESCRIPTION
□	SURFACE MOUNTED DROPPED PRISMATIC CANOPY LIGHTING FIXTURE.
□	NON-FUSED DISCONNECT SWITCH RATED 30 AMPS UNLESS NOTED OTHERWISE. SWITCH MUST BE PAD LOCKABLE IN OPEN POSITION.
□	FUSED DISCONNECT SWITCH RATED 30 AMPS UNLESS NOTED OTHERWISE. SWITCH MUST BE PAD LOCKABLE IN OPEN POSITION.
⊖	DUPLEX RECEPTACLE MOUNTED AT 24" AFF UNLESS INDICATED OTHERWISE. REFER TO SPECIFICATIONS.
⊖ GFCI	DUPLEX RECEPTACLE WITH INTEGRAL PERSONNEL GROUND FAULT CIRCUIT INTERRUPTER (GFCI). REFER TO SPECIFICATIONS.
⊖ WP	WEATHERPROOF DUPLEX RECEPTACLE
●	JUNCTION BOX, CEILING MOUNTED AS INDICATED ON DRAWINGS.
●	WALL MOUNTED JUNCTION BOX.
⊕	SEAL FITTING FOR HAZARDOUS ELECTRICAL INSTALLATIONS. REFER TO NEC ARTICLE 514, PARAGRAPHS 514-6 AND 514-8 FOR SEAL INSTALLATION INFORMATION.
⊕	COMPRESSED NATURAL GAS DETECTOR.
⊕	COMPRESSED NATURAL GAS DETECTION AUDIO / VISUAL DEVICE.
⊕	ELECTRIC MOTOR.
⊕	COMBINATION MAGNETIC MOTOR STARTER FURNISHED AND INSTALLED BY E.C. SWITCH MUST BE PAD LOCKABLE IN OPEN POSITION.
⊕	480V. THREE PHASE, 3-WIRE DISTRIBUTION PANELBOARD.
⊕	120/208V. THREE PHASE, 4-WIRE MISCELLANEOUS LIGHTING AND POWER PANELBOARD.
⊕	277/480V. THREE PHASE, 4-WIRE LIGHTING AND POWER PANELBOARD.
⊕	CONCEALED OR EXPOSED CONDUIT RUN IN CEILING OR WALL. SLANTED LINES DENOTES NUMBER OF CONDUCTORS WHEN MORE THAN TWO. REFER TO SPECIFICATIONS.
⊕	HOMERUN TO PANELBOARD. ARROWHEADS DENOTE NUMBER OF BRANCH CIRCUITS IN CONDUIT.
⊕	CONDUIT CONCEALED IN CONCRETE SLAB OR IN EARTH. REFER TO SPECIFICATIONS.
⊕	CONDUIT WITH HOT WIRE, SWITCHED LEG, NEUTRAL AND GREEN EQUIPMENT GROUND (LEFT-TO-RIGHT)
⊕	UNDERGROUND PRIMARY RADIAL FEEDER. COMPLY WITH LOCAL UTILITY CRITERIA
AFF	ABOVE FINISHED FLOOR.
AFC	ABOVE FINISHED CEILING
AFG	ABOVE FINISHED GRADE
WP	WEATHERPROOF
EC	ELECTRICAL CONTRACTOR.
GC	GENERAL CONTRACTOR.
EL	EMERGENCY LIGHT.
NTS	NOT TO SCALE
GFCI	GROUND FAULT CIRCUIT INTERRUPTER FOR PERSONNEL PROTECTION.
NIC	NOT IN CONTRACT
ETR	EXISTING TO REMAIN
TBR	TO BE REMOVED
⊕	GROUND CONNECTION.
⊕	MOLDED CASE CIRCUIT BREAKER. REFER TO SPECIFICATIONS.
⊕	AVAILABLE FAULT CURRENT AT THE INDICATED LOCATION.
---	DENOTES FIELD WIRING TO BE INSTALLED BY E.C.

LIGHTING FIXTURE SCHEDULE				LAMP SCHEDULE		
TYPE	NOTES	MANUFACTURER & CATALOG NUMBER	BASIC AREA OF USE	TYPE	NO./WATTS	BASE
A	1,2,3,4,5	LITHONIA #KACMLD-1-63B530/50K-SR5-MVOLT-DWHXD	DISPENSER CANOPY	LED	1-180	-
-	-	-	-	-	-	-
-	-	-	-	-	-	-

LIGHTING FIXTURE SCHEDULE NOTES:

- OPERATING VOLTAGE IS 120 VOLT.
- FIXTURE SHALL BE EQUIPPED WITH -20 DEGREE BALLAST.
- FIXTURES SHALL BE U.L. LISTED FOR WET LOCATIONS.
- REFER TO PLANS FOR MOUNTING HEIGHTS.
- PROVIDE FIXTURE WITH INTEGRAL FROM FACTORY 120 VOLT PHOTOELECTRIC CELL.

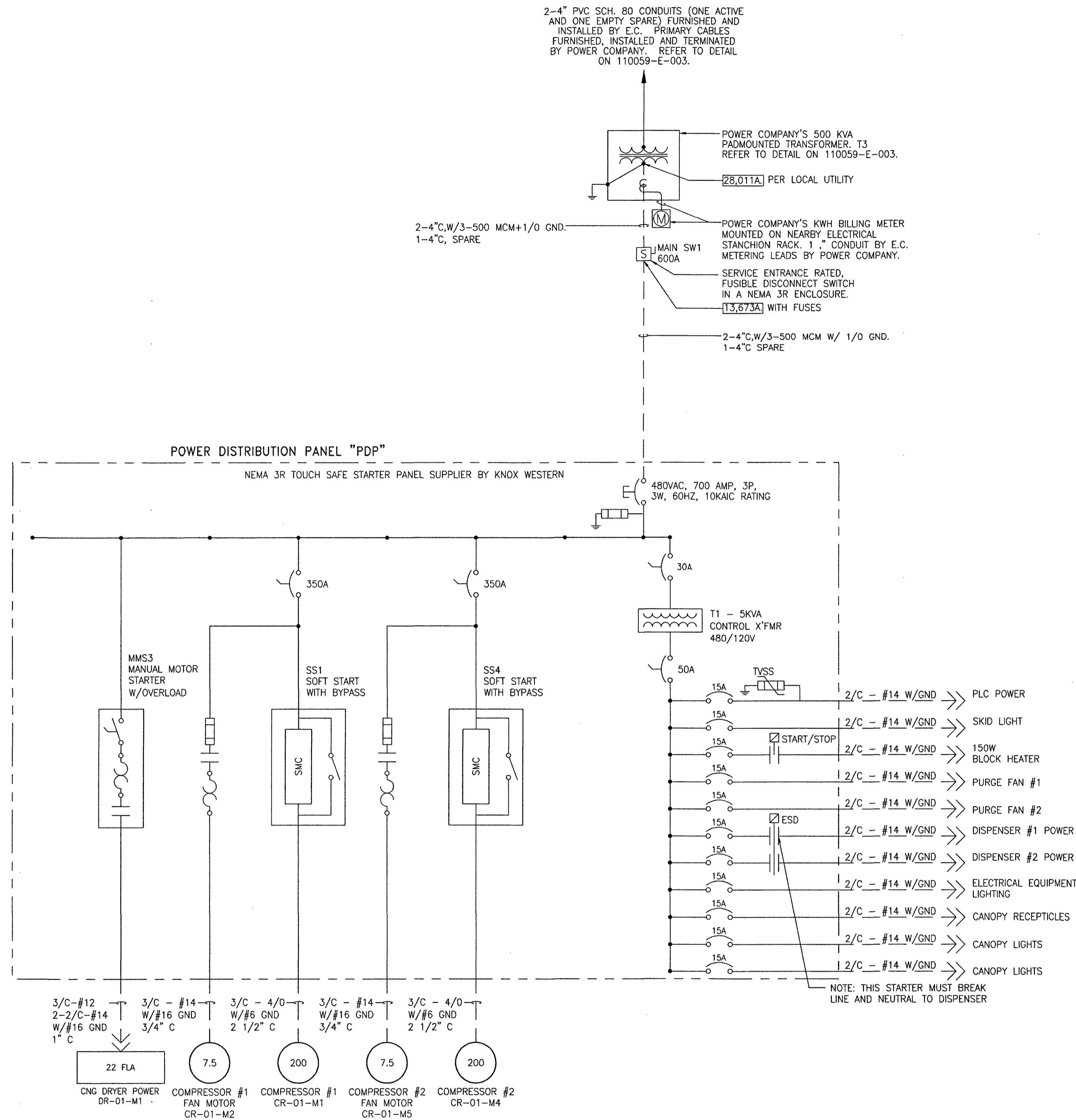

ELECTRICAL ONE-LINE DIAGRAM

NOTES:

- ALL CONDUCTORS ARE COPPER WITH TYPE "THWN/THHN" INSULATION.
- ALL CIRCUIT BREAKERS SHALL BE BOLT-ON TYPE.
- ALL TRANSFORMERS ARE NON-VENTILATED DRY TYPE, 480V, 1-PHASE PRIMARIES AND 120/240V, 1-PHASE, 3 WIRE SECONDARIES
- ALL DISCONNECT SWITCHES ARE 3-POLE, HEAVY DUTY NEMA 3R.
- ELECTRICAL CONTRACTOR SHALL VERIFY AND INSTALL PROPER SIZE OF ALL MOTOR OVERLOAD HEATER ELEMENTS.
- SERVICE ENTRANCE CONDUITS, INCLUDING ALL ELBOWS, LEAVING THE UTILITY PADMOUNTED TRANSFORMER SHALL BE PVC SCH 80.
- ALL CONNECTIONS TO GROUND RODS, COLUMN STEEL AND STANCHIONS SHALL BE MADE WITH AN EXOTHERMIC METHOD.
- ALL LUGS IN ELECTRICAL EQUIPMENT SHALL BE RATED TO ACCEPT 75°C CONDUCTORS.
- ADD GROUND CONDUCTOR IN EACH CONDUIT BETWEEN TRANSFORMER AND MAIN DIST. PANEL ONLY IF REQUIRED BY POWER COMPANY OR LOCAL ELECTRICAL INSPECTOR.
- ALL ELECTRICAL EQUIPMENT ON THIS DRAWING SHALL BE NEW BY THE ELECTRICAL CONTRACTOR UNLESS NOTED OTHERWISE.
- ALL EXPOSED CONDUIT INSTALLED MUST BE HEAVY WALL RIGID GALVANIZED STEEL UNLESS SPECIFICALLY NOTED OTHERWISE.
- REFER TO ANGI VENDOR DRAWINGS FOR ADDITIONAL NOTES.
- ENTIRE ELECTRICAL INSTALLATION SHALL BE IN STRICT ACCORDANCE WITH ALL NATIONAL, STATE AND LOCAL CODES.
- ALL CONDUIT SHALL BE 1" MINIMUM GRC UNLESS NOTED OTHERWISE.
- ALL NEW CONDUCTORS ARE #12 AWG MINIMUM WITH THWN/THHN INSULATION UNLESS NOTED OTHERWISE.

REFERENCE DRAWINGS:

- PROBE AUTOMATION:
AIG-XXXX SHEETS 2 THRU 10
- HGA:
7.110004-E-002 ADRIT CONSTRUCTION RVTD CNG FUELING STATION ELECTRICAL SITE PLAN
7.110004-E-003 ADRIT CONSTRUCTION RVTD CNG FUELING STATION ELECTRICAL DETAILS

APPROVED FOR CONSTRUCTION
DATE: 10/7/11



HUNT, GUILLOT & ASSOCIATES, L.L.C.
CONSULTING ENGINEERS AND PROJECT MANAGERS
P.O. BOX 580 RUSTON, LA 71273

CONFIDENTIAL
THESE DESIGNS AND DRAWINGS ARE THE EXCLUSIVE PROPERTY OF:
HUNT, GUILLOT & ASSOCIATES, RUSTON, LA.
NO COPY OR REPRODUCTION MAY BE MADE WITHOUT WRITTEN APPROVAL.

ADRIT CONSTRUCTION RVTD CNG FUELING STATION ONE-LINE/GENERAL NOTES

DESIGNED BY	JRE	9/9/11	CHECKED BY	DWG	9/14/11
DRAWN BY	JRE	9/9/11	APPROVED BY	RSO	9/14/11
PLOT AT 1: 1	DATE: 9/6/11	HGA JOB NO: 7.110004	HGA ITEM NO:		
ISSUED FOR CONSTRUCTION	DWG	10/7/11	RSO	10/7/11	
SCALE	N.T.S.	DRAWING NUMBER	7.110004-E-001	REV.	0

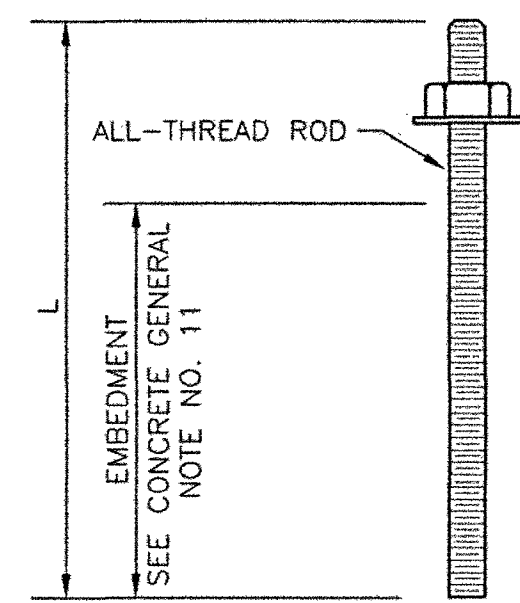
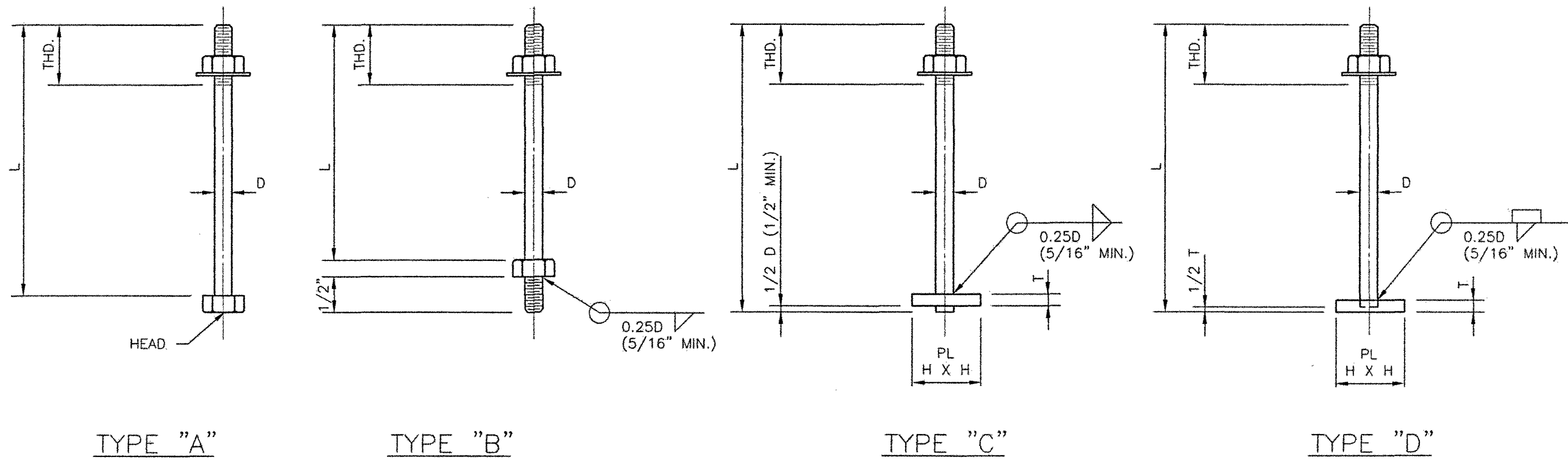

TYPE "E"
ANCHOR RODS USING CHEMICAL ANCHORING SYSTEM

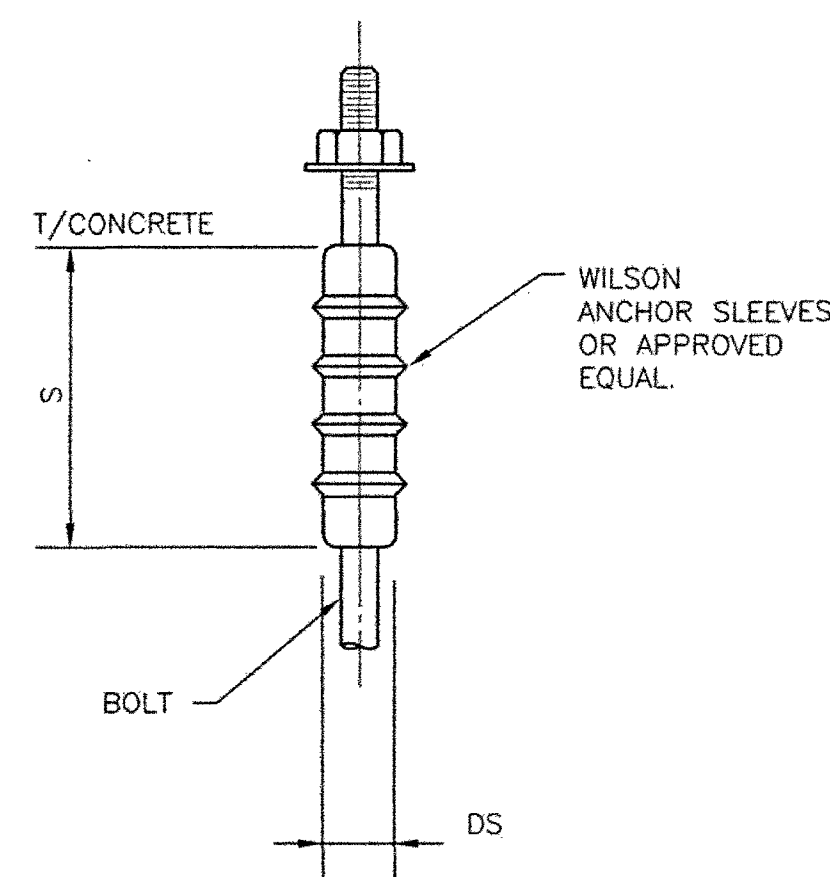

TYP. ANCHOR ROD SLEEVE DETAIL

BOLT DIA. D	LENGTH, L				MIN. THD.	PLATE		SLEEVE DS X S
	TYPE WITHOUT SLEEVE		TYPE WITH SLEEVE			H X H	T	
	A & B	C & D	A & B	C & D				
3/8"	9"		1'-0"		4"		2"x5"	
1/2"	11"		1'-1"		4"		2"x5"	
5/8"	1'-1"		1'-3"		4"		2"x7"	
3/4"	1'-4"	1'-2"	1'-7"	1'-3"	4"	3"x3"	3/4" 2"x7"	
7/8"	1'-6"	1'-3"	1'-8"	1'-5"	4"	3"x3"	3/4" 2"x7"	
1"	1'-9"	1'-4"	2'-1"	1'-8"	4 1/2"	4"x4"	3/4" 3"x10"	
1 1/8"	1'-11"	1'-6"	2'-5"	2'-0"	4 1/2"	4"x4"	3/4" 3"x10"	
1 1/4"	2'-1"	1'-8"	2'-7"	2'-3"	5"	4"x4"	1" 3"x10"	
1 3/8"	2'-3"	1'-9"	2'-11"	2'-5"	5"	5"x5"	1" 4"x1'-3"	
1 1/2"		2'-0"		2'-8"	5 1/2"	5"x5"	1" 4"x1'-3"	
1 3/4"		2'-4"		3'-1"	6"	6"x6"	1 1/4" 4"x1'-3"	
2"		2'-6"		3'-2"	6"	7"x7"	1 1/2" 4"x1'-6"	
2 1/4"		2'-9"		3'-7"	6 1/2"	8"x8"	1 3/4" 4"x1'-6"	
2 1/2"		3'-0"		4'-0"	6 1/2"	8"x8"	1 3/4" 6"x2'-0"	
2 3/4"		3'-3"		4'-5"	7"	9"x9"	1 3/4" 6"x2'-0"	
3"		3'-6"		4'-9"	7"	10"x10"	2" 6"x2'-0"	

* SCHEDULE DOES NOT INCLUDE TYPE "E"

ANCHOR ROD NOTES

- ANCHOR RODS SHALL MEET THE REQUIREMENTS OF ASTM F1554, GRADE 36 UNLESS OTHERWISE NOTED.
- ALL ANCHOR RODS AND NUTS SHALL BE HOT DIPPED GALVANIZED PER ASTM A123 WITH NUTS RETAPPED.
- ANCHOR RODS SHALL BE FURNISHED WITH HEX NUTS AND CUT WASHERS OF SPECIFICATIONS COMPATIBLE WITH THOSE OF THE THREADED SHANKS UNLESS OTHERWISE NOTED. MINIMUM WASHER SIZE AND THICKNESS SHALL COMPLY WITH THE AISC MANUAL OF STEEL CONSTRUCTION.
- THREAD LENGTH SHALL BE AS SHOWN IN ANCHOR ROD STANDARD UNLESS OTHERWISE CALLED FOR IN ANCHOR ROD DESIGNATION.
- ANCHOR ROD LENGTH (L) SHALL BE AS SHOWN IN ANCHOR ROD STANDARD UNLESS OTHERWISE CALLED FOR IN ANCHOR ROD DESIGNATION.
- ANCHOR ROD DESIGNATION SYSTEM.
 - ONLY IF SLEEVE IS REQUIRED.
 - THREAD LENGTH IN INCHES IF NOT AS SHOWN IN STANDARD.
 - IF 2-NUTS ARE REQUIRED
 - ANCHOR ROD TYPE.
 - ANCHOR ROD LENGTH (L) ONLY IF NOT AS SHOWN IN THE ANCHOR ROD SCHEDULE.
 - ANCHOR ROD DIAMETER (D).
- ALL ANCHOR RODS TO BE TAGGED BY THE FABRICATOR THUS:
 - 1 1/4" 1'-10" ASNB, XXXX
 - DWG. NO. ON WHICH DESIGNATION IS SHOWN.
 - ANCHOR ROD DESIGNATION.
- ANCHOR RODS SHALL BE CLEAN AND FREE OF ANY OILS OR OTHER FOREIGN MATERIALS PRIOR TO PLACEMENT.
- MEANS SHALL BE USED TO PREVENT CONCRETE FROM CONTACTING THE PROJECTING PART OF THE ANCHOR ROD.

CONCRETE & REINFORCEMENT GENERAL NOTES

- DESIGN, MATERIAL, AND WORKMANSHIP SHALL BE IN ACCORDANCE WITH THE CURRENT EDITION OF THE FOLLOWING STANDARDS:
 - ACI 318 BUILDING CODE REQUIREMENTS FOR REINFORCED CONCRETE.
 - SP66 ACI DETAILING MANUAL.
 - ACI 301 SPECIFICATIONS FOR STRUCTURAL CONCRETE FOR BUILDINGS.
 - CRSI RECOMMENDED PRACTICE FOR PLACING REINFORCING STEEL.
- CONCRETE SHALL DEVELOP 4000 PSI MINIMUM COMPRESSIVE STRENGTH AT 28 DAYS, UNLESS NOTED OTHERWISE.
- REINFORCING STEEL SHALL BE DEFORMED BARS CONFORMING TO ASTM A615 GRADE 60.
- WELDED WIRE FABRIC SHALL CONFORM TO ASTM A185, (FLAT SHEETS ONLY).
- UNLESS NOTED OTHERWISE, CONCRETE COVER OVER REINFORCING SHALL BE:
 - 3" WHEN THE CONCRETE IS PLACED DIRECTLY AGAINST THE GROUND.
 - 2" FOR BARS LARGER THAN NO. 5, AND 1 1/2" FOR NO. 5 AND SMALLER, IF AFTER REMOVAL OF FORMS THE CONCRETE IS EXPOSED DIRECTLY TO WEATHER OR GROUND.
 - 1" IN SLABS AND WALLS, AND 1 1/2" FOR BEAMS AND COLUMNS NOT EXPOSED DIRECTLY TO WEATHER OR GROUND.
- UNLESS OTHERWISE SHOWN, THE MINIMUM LAP FOR BAR SPLICES SHALL BE PER ACI 318.
- ALL REINFORCING HOOKS SHALL BE STANDARD HOOKS AS DEFINED BY ACI 318.
- ALL EXPOSED EDGES OF CONCRETE SHALL HAVE A 1 INCH, 45 DEGREE CHAMFER.
- A 1/2" BITUMASTIC PREFORMED EXPANSION JOINT SHALL BE PLACED AT ALL LOCATIONS NOTED ON THE DRAWINGS AND ALSO AROUND ALL FOUNDATIONS WHICH PROJECT THROUGH CONCRETE SLABS. ALL EXPANSION JOINTS SHALL BE SEALED WITH "SLI" AS MANUFACTURED BY SONNEBORN OR APPROVED EQUAL. PROCEDURES AND WORKMANSHIP SHALL CONFORM TO MANUFACTURER'S RECOMMENDATIONS. CONTROL JOINTS SHALL BE PLACED AT 15' EACH DIRECTION, UNLESS NOTED OTHERWISE.
- PRIOR TO PLACING CONCRETE, REFER TO PLUMBING, PIPING AND ELECTRICAL DRAWINGS FOR UNDERGROUND AND EMBEDDED ITEMS NOT SHOWN ON STRUCTURAL DRAWINGS.
- ANCHOR RODS AND REINFORCING BARS, WHERE INDICATED TO BE INSTALLED USING A CHEMICAL ANCHORING SYSTEM, SHALL BE FIELD DRILLED AND INSTALLED USING THE "HILTI" HIT HY 150 ANCHORING SYSTEM OR APPROVED EQUAL. THE CONTRACTOR SHALL INSTALL PER ANCHORING SYSTEM PRODUCT INSTRUCTIONS TO FULLY DEVELOP THE ANCHOR BOLTS OR REINFORCEMENT BARS. (THIS WILL INCLUDE, BUT NOT BE LIMITED TO THE DRILLED HOLE DIAMETER AND DEPTH).
- ALL NEW CONCRETE SHALL BE BONDED TO EXISTING CONCRETE WITH THE USE OF AN ASTM C881, TYPE I OR II, GRADE 1, 2, OR 3, CLASS B OR C EPOXY RESIN ADHESIVE. EXISTING CONCRETE WHICH IS TO BE BONDED TO NEW CONCRETE SHALL BE ABRASIVE BLASTED, BUSH HAMMERED OR OTHERWISE BROUGHT TO A FULL AMPLITUDE OF 1/4". ALL SURFACES SHALL BE INSPECTED AFTER BEING ROUGHENED AND CLEANED. ALL LOOSE PIECES OF CONCRETE SHALL BE REMOVED AND ALL CRACKS SHALL BE PRESSURE GROUTED WITH AN EPOXY RESIN GROUT AS SPECIFIED ABOVE. PROCEDURES AND WORKMANSHIP SHALL CONFORM TO "STANDARD SPECIFICATIONS FOR BONDING PLASTIC CONCRETE TO HARDENED CONCRETE WITH A MULTI-COMPONENT EPOXY ADHESIVE", ACI 503.2 AND AS RECOMMENDED BY THE MANUFACTURER. GROUT MATERIAL SHALL BE APPROVED BY THE ENGINEER.
- EXPANSION BOLTS SHALL BE HILTI-KWIK BOLT 3 OR ENGINEER APPROVED EQUAL. BOLTS SHALL BE TORQUED TO MANUFACTURER'S STANDARD TORQUE VALUES.
- GROUT FOR COLUMN BASE PLATES SHALL BE "FIVE STAR" NON-SHRINK CEMENT GROUT BY U.S. GROUT CORPORATION OR APPROVED EQUAL UNLESS OTHERWISE NOTED.
- ALL COLUMN BASE PLATES SHALL BE GROUTED TO PROVIDE FULL UNIFORM LOAD TRANSFER TO THE CONCRETE FOUNDATIONS. SHIMS SHALL BE REMOVED AND THE VOIDS SHALL BE GROUTED AFTER THE GROUT HAS CURED. NUTS SHALL BE TIGHTENED AFTER THE GROUT HAS CURED.
- REINFORCING BARS SHALL BE SUPPORTED ON CHAIRS AND SPACERS PER ACI 315.
- ALL WATERSTOPS SHALL BE ADEKA ULTRA SEAL P-201 OR ADEKA ULTRA SEAL P-201 WITH KBA-1510FP, OR APPROVED EQUAL.

SPECIAL INSPECTION - SITE AND FOUNDATIONS

- SPECIAL INSPECTIONS SHALL MEET THE REQUIREMENTS OF IBC SECTION 1704. SPECIAL INSPECTOR ADMINISTRATOR(S) SHALL BE HIRED TO PERFORM THE REQUIRED SPECIAL INSPECTIONS. THE NAMES OF PERSONS OR FIRMS WHO ARE TO PERFORM THE SPECIAL INSPECTIONS SHALL BE FORWARDED TO THE BUILDING OFFICIAL FOR APPROVAL. THE SPECIAL INSPECTOR ADMINISTRATOR(S) SHALL COMPLETE AND SUBMIT ALL FORMS REQUIRED BY THE CITY OF
- THE SPECIAL INSPECTOR ADMINISTRATOR(S) SHALL:
 - OBSERVE THE WORK ASSIGNED FOR CONFORMANCE TO THE APPROVED DRAWING AND SPECIFICATIONS.
 - FURNISH MONTHLY INSPECTION REPORTS TO THE REGISTERED DESIGN PROFESSIONAL IN RESPONSIBLE CHARGE AND BUILDING OFFICIAL. DISCREPANCIES SHALL BE BROUGHT TO THE IMMEDIATE ATTENTION OF THE CONTRACTOR FOR CORRECTION, THEN, IF NOT CORRECTED, TO THE DESIGN PROFESSIONAL IN RESPONSIBLE CHARGE AND THE BUILDING OFFICIAL.
 - SUBMIT TO THE DESIGN PROFESSIONAL IN RESPONSIBLE CHARGE AND THE BUILDING OFFICIAL A SIGNED FINAL REPORT STATING THAT THE WORK WAS IN CONFORMANCE WITH THE APPROVED DRAWINGS AND SPECIFICATIONS AND THE APPLICABLE WORKMANSHIP PROVISIONS OF THE IBC.
- SPECIAL INSPECTION NOTES:
 - CONTINUOUS SPECIAL INSPECTION IS ALWAYS REQUIRED DURING THE PERFORMANCE OF THE WORK UNLESS SPECIFICALLY NOTED BELOW.
 - IT IS THE RESPONSIBILITY OF THE CONTRACTOR TO PROVIDE THE SPECIAL INSPECTOR ADMINISTRATOR(S) WITH ADVANCE NOTICE, NO LESS THAN ONE WORKING DAY, OF THE INITIATION OF ANY WORK TO HAVE SPECIAL INSPECTIONS. ALL WORK PERFORMED WITHOUT REQUIRED SPECIAL INSPECTION WILL BE SUBJECT TO REMOVAL.
- TYPES OF WORK REQUIRING SPECIAL INSPECTION ARE:
 - SPECIAL INSPECTION FOR EXISTING SOIL CONDITIONS, DURING SITE PREPARATION AND FILL PLACEMENT, TO ENSURE LOAD-BEARING REQUIREMENTS IN COMPLIANCE WITH IBC SECTION 1704.7 EXCEPT AS ALLOWED IN IBC SECTION 1704.7.
 - SITE PREPARATION:
 - PRIOR TO PLACEMENT OF THE PREPARED FILL, THE SPECIAL INSPECTOR SHALL DETERMINE THAT THE SITE HAS BEEN PREPARED IN ACCORDANCE WITH THE SPECIFICATION. (FREQUENCY OF INSPECTION-ONCE EVERY 500 SQUARE FOOT AREA OR LESS)
 - DURING FILL PLACEMENT:
 - DURING PLACEMENT AND COMPACTION OF FILL MATERIAL, THE SPECIAL INSPECTOR SHALL DETERMINE THAT THE MATERIAL BEING USED, MOISTURE CONTENT, AND THE MAXIMUM LIFT THICKNESS COMPLY WITH THE SPECIFICATION. (FREQUENCY OF INSPECTION-ONCE EVERY 500 SQUARE FOOT AREA OR LESS)
 - EVALUATION OF IN-PLACE DENSITY:
 - THE SPECIAL INSPECTOR SHALL DETERMINE, AT THE APPROVED FREQUENCY, THAT THE IN-PLACE DRY DENSITY OF THE COMPACTED FILL AND THE FOUNDATION SUBGRADE COMPLIES WITH THE SPECIFICATION. (FREQUENCY OF INSPECTION-ONCE EVERY 500 SQUARE FOOT AREA OR LESS)
 - CONCRETE CONSTRUCTION AS REQUIRED BY IBC SECTION 1704.4 AND TABLE 1704.4, EXCEPT AS ALLOWED IN IBC SECTION 1704.4.
 - INSPECT SOILS BELOW ALL FOOTINGS FOR ADEQUATE BEARING CAPACITY AND CONSISTENCY WITH GEOTECHNICAL REPORT. INSPECT REMOVAL OF UNSUITABLE MATERIAL AND PREPARATIONS OF SUBGRADE PRIOR TO PLACEMENT OF CONTROLLED FILL. (CONTINUOUS INSPECTION REQUIRED)
 - INSPECTION OF REINFORCING STEEL AND PLACEMENT. THIS INSPECTION SHALL INCLUDE CHECKING REBAR SIZE, SPACING, NUMBER, LAP SPLICES, DEVELOPMENT LENGTH FOR COMPLIANCE WITH APPROVED DRAWINGS. ALSO VERIFY MATERIAL CERTIFICATION REPORT. (INSPECT EACH FOUNDATION)
 - INSPECTION OF BOLTS TO BE INSTALLED IN CONCRETE PRIOR TO AND DURING PLACEMENT OF CONCRETE. THIS INSPECTION SHALL INCLUDE CHECKING BOLT SIZES, LOCATION, BOLT PATTERN AND ORIENTATION, ELEVATION, ANCHORAGE DETAIL AND EMBEDMENT LENGTH FOR COMPLIANCE WITH APPROVED DRAWING. (CONTINUOUS INSPECTION REQUIRED)
 - VERIFYING USE OF THE REQUIRED MIX DESIGN. THIS INSPECTION SHALL INCLUDE CHECKING BATCH PLANT'S TICKET FOR CONCRETE MIX, ADDITIVES, WATER CEMENT RATIOS AND THE TIME WHEN WATER IS ADDED TO THE MIX. (FREQUENCY OF INSPECTION-ONCE EVERY 50 CYD OF CONCRETE MINIMUM-ONCE PER FOUNDATION)
 - AT THE TIME FRESH CONCRETE IS SAMPLED TO FABRICATE SPECIMENS FOR STRENGTH TESTS. ALSO PERFORM SLUMP AND AIR CONTENT TESTS, AND DETERMINE THE TEMPERATURE OF THE CONCRETE. (CONTINUOUS INSPECTION REQUIRED)
 - INSPECTION OF CONCRETE PLACEMENT FOR PROPER APPLICATION TECHNIQUES. THE INSPECTOR SHALL OBSERVE THAT THE CONCRETE IS NOT SEGREGATED DURING PLACEMENT AND PROPERLY VIBRATED AND THE PLACEMENT IS COMPLETED WITHIN THE TIME PERIOD SPECIFIED. (CONTINUOUS INSPECTION REQUIRED)
 - INSPECTION OF MAINTENANCE OF SPECIFIED CURING TEMPERATURE AND TECHNIQUES, INCLUDING PROTECTION OF THE CONCRETE FROM HOT/COLD WEATHER CONDITIONS. (INSPECT EACH FOUNDATION)

APPROVED FOR CONSTRUCTION
DATE: 10/12/11

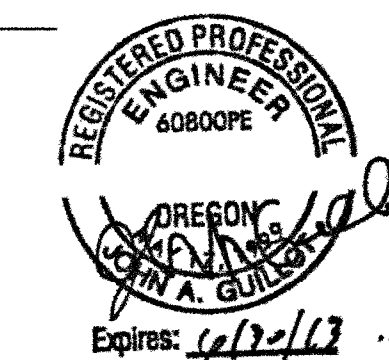

HUNT, GUILLOT & ASSOCIATES, L.L.C.
CONSULTING ENGINEERS AND PROJECT MANAGERS
P.O. BOX 580 RUSTON, LA 71273

CONFIDENTIAL
THESE DESIGNS AND DRAWINGS ARE THE EXCLUSIVE PROPERTY OF:
HUNT, GUILLOT & ASSOCIATES, RUSTON, LA.
NO COPY OR REPRODUCTION MAY BE MADE WITHOUT WRITTEN APPROVAL.

CONCRETE GENERAL NOTES
SPECIAL INSPECTION NOTES
ANCHOR BOLT DETAILS

DESIGNED BY	HGA	11-13-08	CHECKED BY	CEH	9-14-11
DRAWN BY	ADM	1-23-03	APPROVED BY	RSO	9-14-11
PLAT AT 1: 1-1	DATE: 1-23-03	HGA JOB NO: 7110004	HGA ITEM NO:		
SCALE	DRAWING NUMBER		REV.		
NONE	STD-F-001		0		

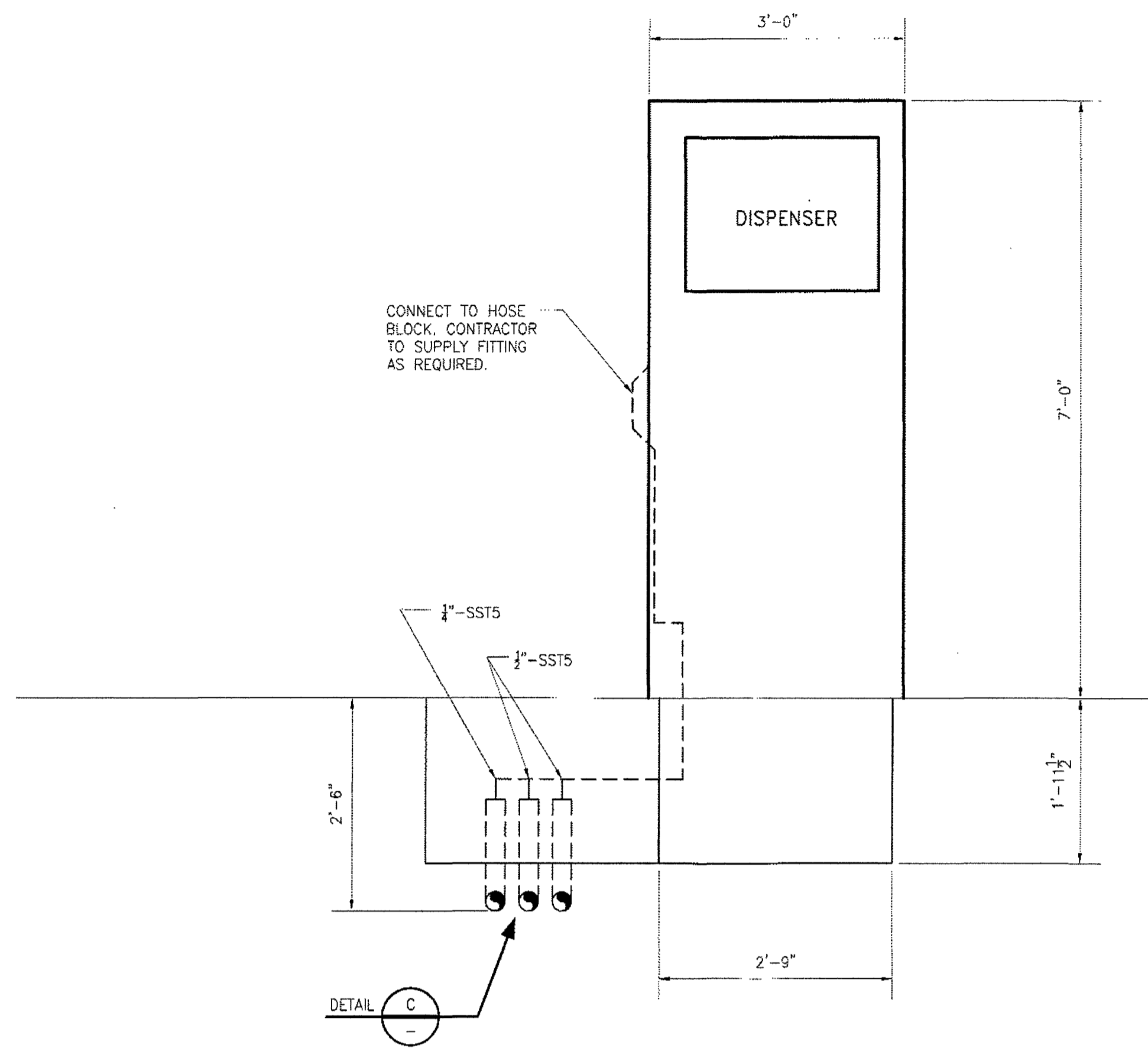

SECTION A
SCALE: 3/4"=1'-0"
7.110004-M-003

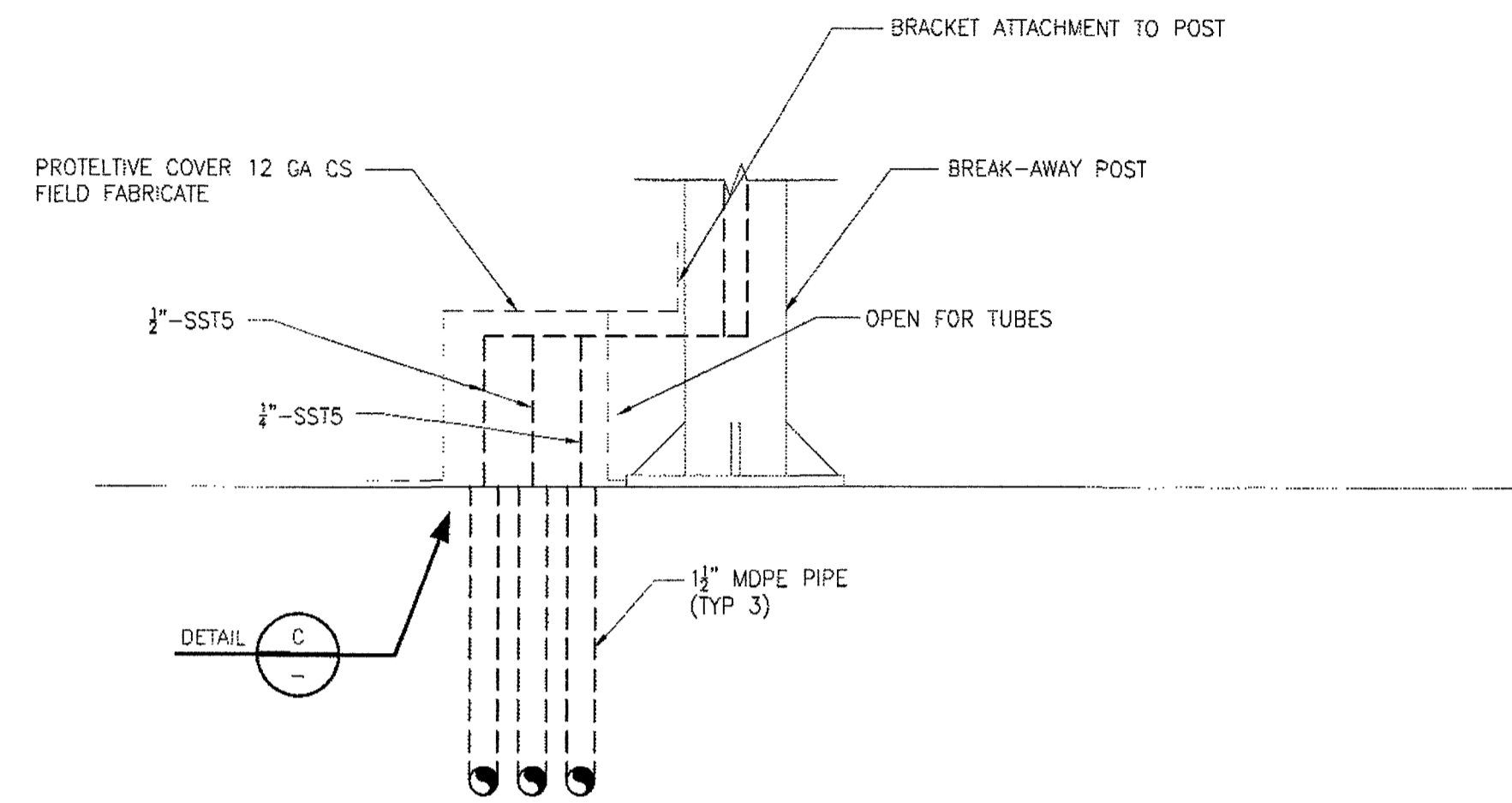

SECTION B
SCALE: 3/4"=1'-0"
7.110004-M-003

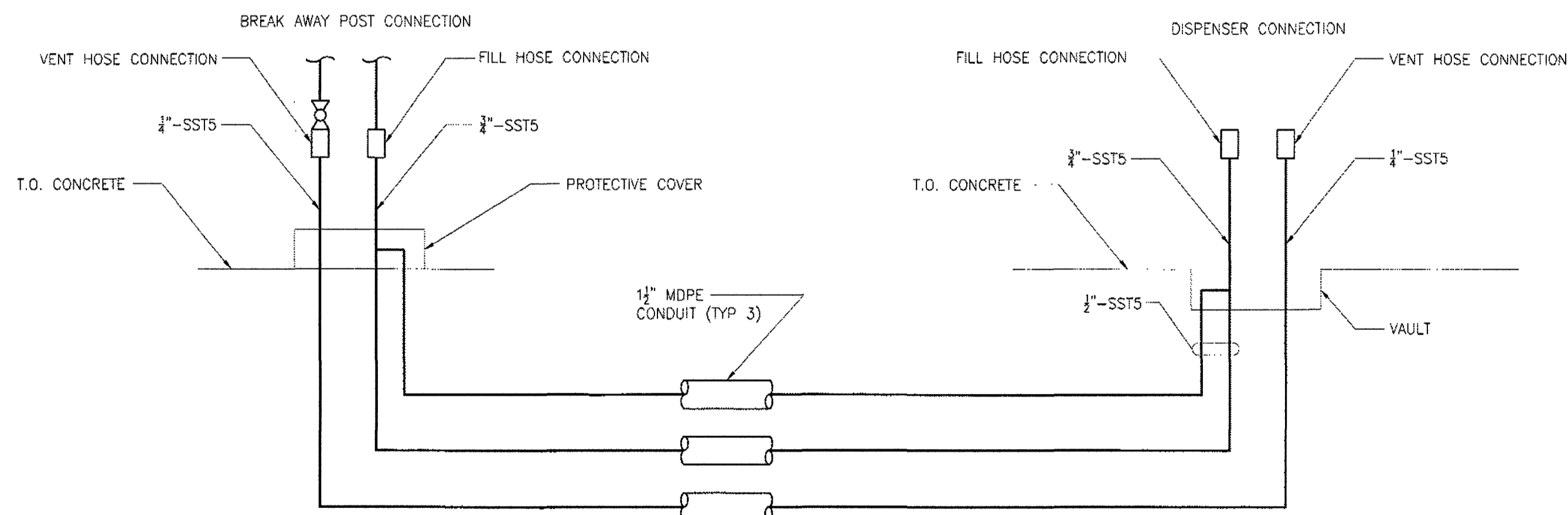

DETAIL C
SCALE: NONE
REMOTE FILL POST SCHEMATIC

NOTE:
CONTRACTOR TO SUPPLY FITTINGS
AS REQUIRED TO CONNECT TO
DISPENSER AND BREAK-AWAY
HOSE POST.

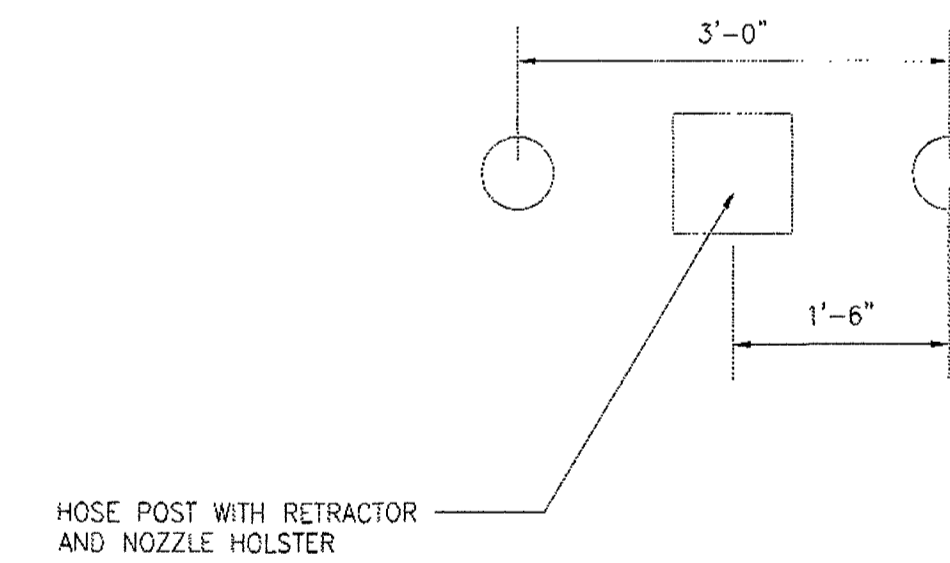

DETAIL D
SCALE: 3/4"=1'-0"
7.110004-M-003

APPROVED FOR
CONSTRUCTION
DATE: 7/19/12



HUNT, GUILLOT & ASSOCIATES, L.L.C.
CONSULTING ENGINEERS AND PROJECT MANAGERS
P.O. BOX 580 RUSTON, LA 71273
MODEL ID: _____
CONFIDENTIAL
THESE DESIGNS AND DRAWINGS ARE THE EXCLUSIVE PROPERTY OF:
HUNT, GUILLOT & ASSOCIATES, RUSTON, LA.
NO COPY OR REPRODUCTION MAY BE MADE WITHOUT WRITTEN APPROVAL.

ADROIT CONSTRUCTION
RVTD CNG FUELING STATION
SECTIONS AND DETAILS

DESIGNED BY	AW	7/18/12	CHECKED BY	SBS	7/17/12
DRAWN BY	JRE	7/16/12	APPROVED BY	RSO	7/18/12
PLOT AT 1:	1	DATE: 7/16/12	HGA JOB NO: 7.110004	HGA ITEM NO:	
SCALE	DRAWING NUMBER		REV.		
AS NOTED	7.110004-M-006		0		

PIPING MATERIAL SPECIFICATION: CS15 (CARBON STEEL, CLASS 150)

ITEM	NOTES	NPS	SCH/RAT	ENDS	DESCRIPTION	USER CODES
PIPE	19, 136					
	1001	1/2 - 1-1/2	XS		CS, SMLS, ASTM A106-B or A53-B, type S (E=1.0)	
	1001	2 - 6	STD		CS, ERW, A53-B type E (E=0.85)	
NIPPLES	03, 19					
Branch Swage (CONC)		1/2 - 1-1/2	XS		CS, SMLS, ASTM A106-B or A53-B, type S or API 5L-B (E=1.0)	
Swage (ECC)		1/2 - 1-1/2	XS		CS, ASTM A234-WPB-S, MSS SP-95	
FITTINGS	02, 03					
90 ELL		1/2 - 1-1/2	3000#	SW	CS, ASTM A105, ASME B16.11	
Tee		1/2 - 1-1/2	3000#	SW	CS, ASTM A105, ASME B16.11	
Tee (RED)		1/2 - 1-1/2	3000#	SW	CS, ASTM A105, ASME B16.11	
Coupling		1/2 - 1-1/2	3000#	SW	CS, ASTM A105, ASME B16.11	
Coupling		1/2 - 1-1/2	3000#	SW	CS, ASTM A105, ASME B16.11	
Cap		1/2 - 1-1/2	3000#	SW	CS, ASTM A105, ASME B16.11	
Reducing		1/2 - 1-1/2	3000#	SW	CS, ASTM A105, MSS SP-79	
Union (GJ)		1/2 - 1-1/2	3000#	SW	CS, ASTM A105, integral seat, MSS SP-83	
Reducer (CONC)		2 - 6		Weld	CS, ASTM A234-WPB-W, ASME B16.9	
Reducer (ECC)		2 - 6		Weld	CS, ASTM A234-WPB-W, ASME B16.9	
Weldolet		2 - 6		Weld	CS, ASTM A105, MSS SP-97	
90 LR ELL		2 - 6		Weld	CS, ASTM A234-WPB-W, ASME B16.9	
Tee		2 - 6		Weld	CS, ASTM A234-WPB-W, ASME B16.9	
Cap		2 - 6		Weld	CS, ASTM A234-WPB-S, ASME B16.9	
VALVES						
Gate	15	1/2 - 2	150#	RF	CS body w/ 13 CR trim, HF ST	
Gate		1/2 - 2	150#	SW	CS body w/ 13 CR trim, HF ST	
Gate	06	1/2 - 2	800#	THRD	CS body w/ 13 CR trim, HF ST	
Gate		3 - 6	150#	RF	CS body w/ 13 CR trim, HF ST, FP	
FLANGES	02					
Socket		1/2 - 1-1/2	150#	RF	CS, ASTM A105, ASME B16.5	
Blind		1/2 - 6	150#	RF	CS, ASTM A105, ASME B16.5	
Slip-on		2 - 6	150#	RF	CS, ASTM A105, ASME B16.5	
Weld Neck	13	2 - 6	150#	RF	CS, ASTM A105, ASME B16.5	
Pair WN		2 - 6	150#	RF	CS, ASTM A105, ASME B16.36, SW	
GASKETS						
		1/2 - 6	150#		1/16" thick flexible graphite w/ 304 or 316 SS corrugated insert, ASME B16.21	
BOLTING						
Stud Bolts					ASTM A193, Gr B7 stud w/ 2 heavy hex nuts ASTM A194, Gr 2H	

90° BRANCH CONNECTION

Size on Size: Tee
Reduced Size on Size: Reducing Tee. Use sockolet or weldolet if reducing tee not available.

NOTES:

- 02 All butt-welded component thicknesses shall match pipe thickness.
- 03 Threaded joints are permitted only at outlet of vent and drain valves, at hydrostatic connections, at outlet of instrument take-off valves, and to match equipment.
- 06 These valves shall be used only for vent, drain, and instrument connections.
- 13 Weld neck flanges shall be used against butt-weld fittings. Otherwise, use slip-on flanges.
- 15 To be used when mating to flanged nozzles.
- 19 Sch 160 pipe and pipe nipples shall be used for threaded connections for sizes NPS 1/2 - 1-1/2
- 136 Sch XS pipe shall be used for threaded connections for size NPS 2.

1001 GENERAL NOTES

PIPE SUPPORTS

Diameter	Spacing	Diameter	Spacing
1/2"	8.5 ft	2"	16.0 ft
3/4"	10.0 ft	3"	21.5 ft
1"	12.0 ft	4"	25.5 ft
1 1/2"	15.5 ft	6"	30.5 ft

Provide supports at ells and equipment connections
Use MAPA or equal nylon based roller support where applicable.

Underground pipe shall be coated and wrapped. System to be approved by Engineer.
All pipe shall be fabricated, install, inspected and hydrotested in accordance with ASME B31.3.

PIPING MATERIAL SPECIFICATION: SSTS (STAINLESS STEEL TUBE, 5000 PSIG)

ITEM	NOTE S	TUBE O.D.	WALL THICK	ENDS	DESCRIPTION	USER CODE
TUBING	1, 4, 5	1/4	.035"		TYPE 316 ASTM A269 OR 312, SMLS	
	1, 4, 5	3/8	.065"		TYPE 316 ASTM A269 OR 312, SMLS	
	1, 4, 5	1/2	.065"		TYPE 316 ASTM A269 OR 312, SMLS	
	1, 4, 5	5/8	.083"		TYPE 316 ASTM A269 OR 312, SMLS	
	1, 4, 5	3/4	.109		TYPE 316 ASTM A269 OR 312, SMLS	
	1, 4, 5	1	.127"		TYPE 316 ASTM A269 OR 312, SMLS	
FITTINGS					Swagelock or Equal	
VALVES						
	Ball	2, 3	1/4-1		Swagelock Series SS-AF or Equal	

BRANCH CONNECTIONS

SIZE-ON-SIZE

Tee

SIZE ON SMALLER BRANCH

Reducing Tee

NOTES:

- 1 Underground tubing shall be run through MDPE yellow gas pipe, SDR=11, manufactured per ASTM D2513. Material per ASTM D3350.
- 2 Fittings and valves shall be installed according to manufacturers instructions.
- 3 Fittings and valves shall have a minimum pressure rating of 5000 psig
- 4 Tubing bends are acceptable if made with a commercial bender. Smallest diameter after bending shall be no more than 8 percent less than the diameter before bending.

5 PIPE SUPPORTS

Diameter	Spacing
1/4"	6 ft
3/8"	8 ft
1/2"	9 ft
3/4"	11 ft
1"	13 ft

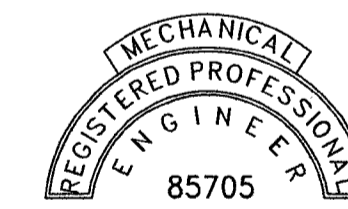

APPROVED FOR CONSTRUCTION
DATE: 10/7/11

APPROVED FOR CONSTRUCTION
DATE: 10/7/11

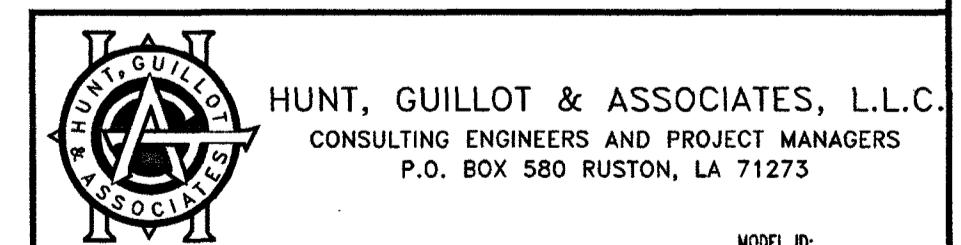

CONFIDENTIAL
THESE DESIGNS AND DRAWINGS ARE THE EXCLUSIVE PROPERTY OF:
HUNT, GUILLOT & ASSOCIATES, RUSTON, LA.
NO COPY OR REPRODUCTION MAY BE MADE WITHOUT WRITTEN APPROVAL.

ADROIT CONSTRUCTION
RVTD CNG FUELING STATION
PIPING SPECIFICATIONS

DESIGNED BY	AW	9/8/11	CHECKED BY	SBS	9/14/11
DRAWN BY	JRE	9/8/11	APPROVED BY	RO	9/14/11
PLOT AT 1:	1	DATE: 9/8/11	HGA JOB NO: 7.110004	HGA ITEM NO:	
0 ISSUED FOR CONSTRUCTION	SBS	10/7/11	RSO	10/7/11	
SCALE	N.T.S.	DRAWING NUMBER	7.110004-M-004	REV.	0
REV.	DESCRIPTION	CHK.	DATE	APP.	DATE

MATCH LINE SEE DWG 7.110004-M-002

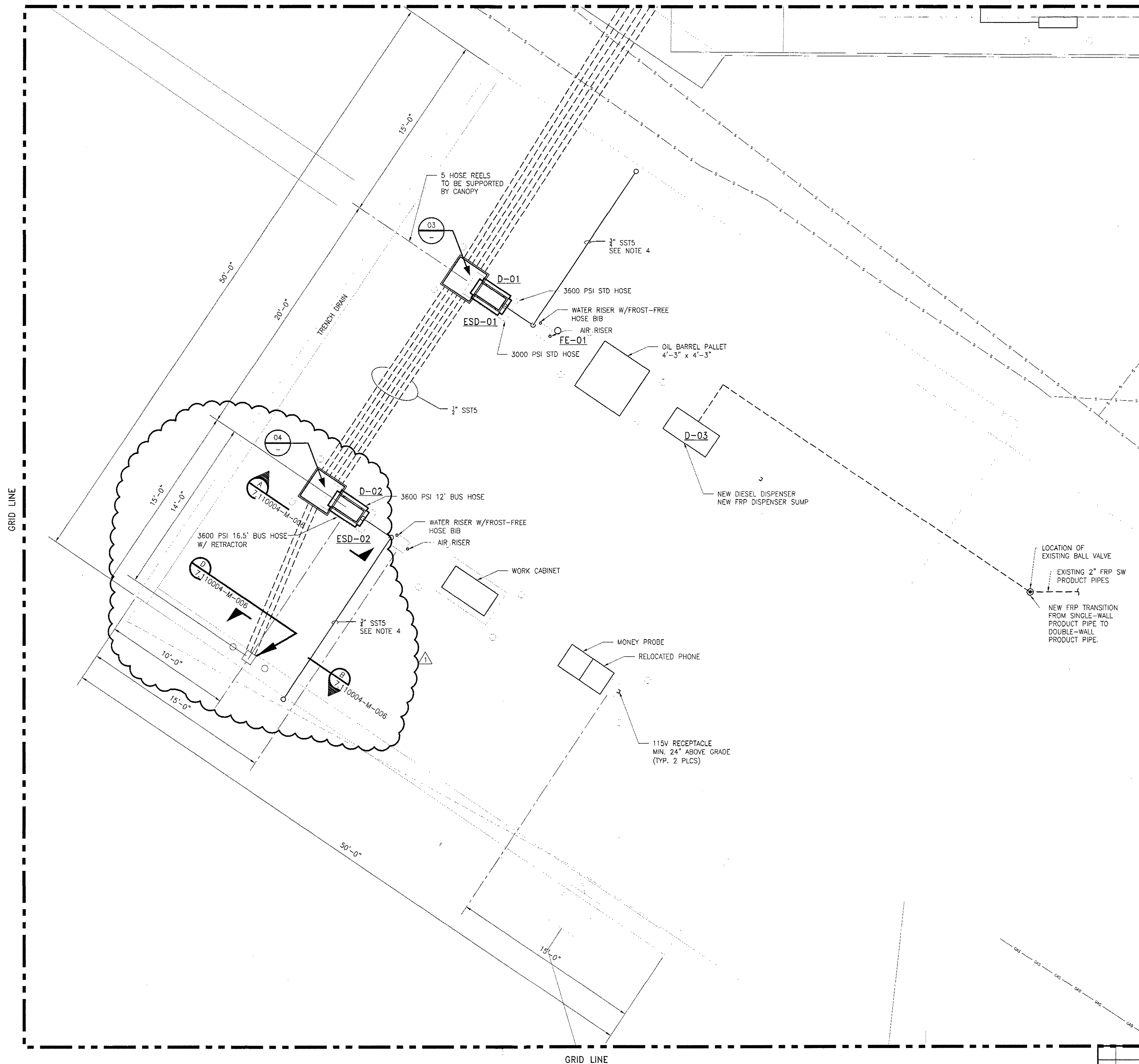
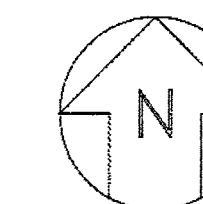

EQUIPMENT IDENTIFICATION:

EQUIP. NO.	DESCRIPTION
C-01	CNG COMPRESSOR SKID NO. 1
C-02	CNG COMPRESSOR SKID NO. 2
D-01	CNG DISPENSER NO. 1 (STANDARD)
D-02	CNG DISPENSER NO. 2 (BUS)
D-03	DIESEL DISPENSER
DPP-01	DEFUELING PANEL
DR-01	NATURAL GAS DRYER
ESD-01	EMERGENCY SHUTDOWN NO. 1 (ON DISPENSER)
ESD-02	EMERGENCY SHUTDOWN NO. 2 (ON DISPENSER)
ESD-03	EMERGENCY SHUTDOWN NO. 3
FE-01	FIRE EXTINGUISHER NO. 1 (TYPE 20 B/C)
FE-02	FIRE EXTINGUISHER NO. 2 (TYPE 20 B/C)
M-01	GAS METER
PP-01	PRIORITY PANEL
T-01	CNG STORAGE TANK NO. 1 (LOW PRESSURE)
T-02	CNG STORAGE TANK NO. 2 (MEDIUM PRESSURE)
T-03	CNG STORAGE TANK NO. 3 (HIGH PRESSURE)
T-04	CNG STORAGE TANK NO. 4 (LOW PRESSURE, EXISTING RELOCATED)

- NOTES:**
- PIPE LOCATIONS ARE APPROXIMATE.
 - ALL UNDERGROUND PIPE SHALL BE BURIED 2'-6" MINIMUM BELOW SURFACE.
 - SEE DRAWING 7.110004-M-004 FOR PIPE SPECIFICATIONS.
 - RUN DISPENSER VENT LINE FROM CONNECTION AT TOP OF DISPENSER UP CANOPY COLUMN AND TERMINATE AT CANOPY EDGE. INSTALL SWAGELOK OR EQUAL VENT PROTECTOR.
 - FOR REFERENCE DRAWINGS SEE DWG. 7.110004-M-001.
 - CONTRACTOR TO PROVIDE 1/4-TURN BALL VALVES.

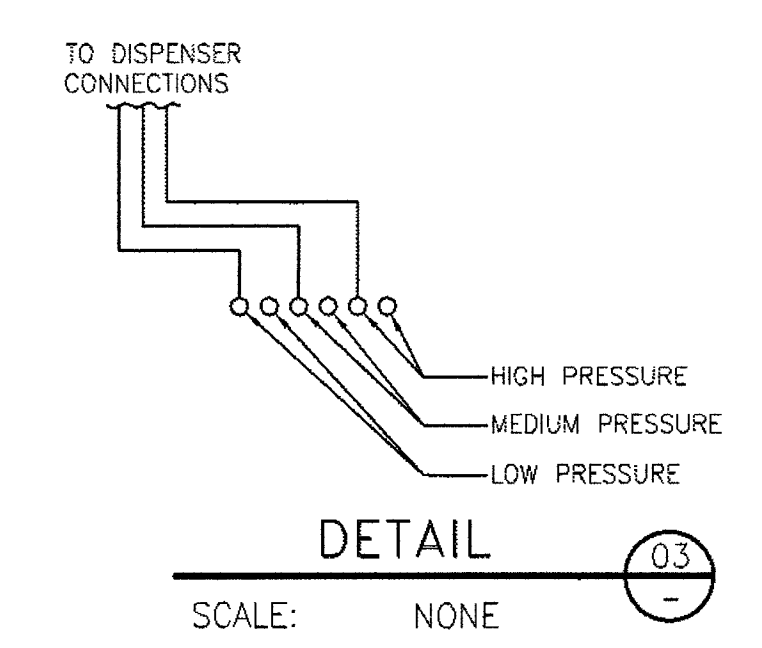

APPROVED FOR CONSTRUCTION
DATE: 7/19/12

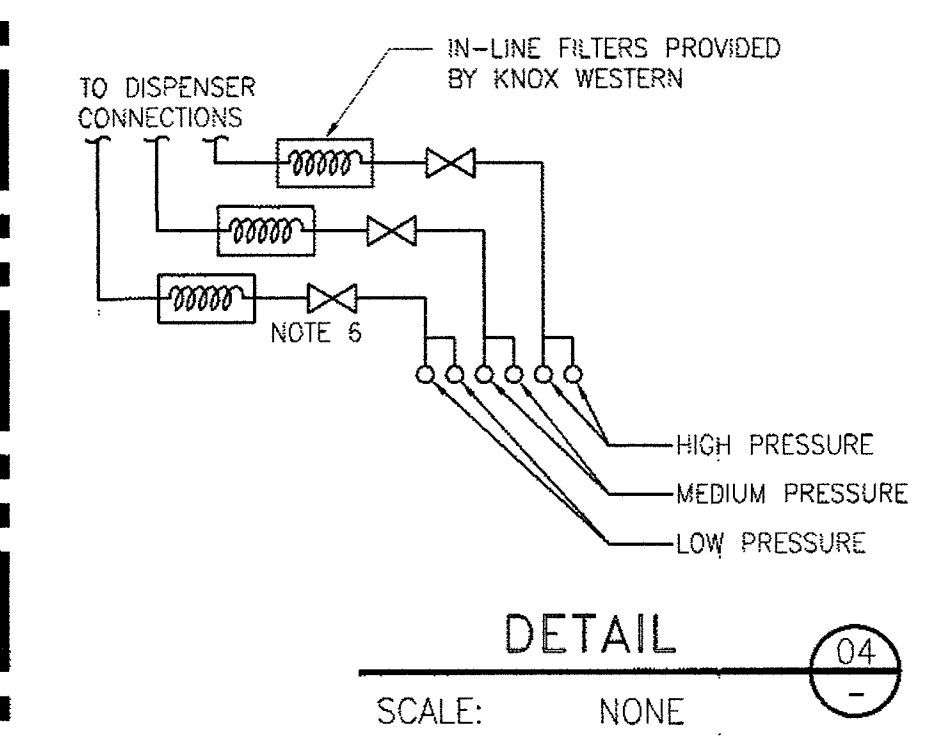

HUNT, GUILLOT & ASSOCIATES, L.L.C.
CONSULTING ENGINEERS AND PROJECT MANAGERS
P.O. BOX 580 RUSTON, LA 71273

CONFIDENTIAL
THESE DESIGNS AND DRAWINGS ARE THE EXCLUSIVE PROPERTY OF:
HUNT, GUILLOT & ASSOCIATES, RUSTON, LA.
NO COPY OR REPRODUCTION MAY BE MADE WITHOUT WRITTEN APPROVAL.

ADROIT CONSTRUCTION
RVTD CNG FUELING STATION
DISPENSER LAYOUT

REV.	DESCRIPTION	CHK.	DATE	APP.	DATE	SCALE	DRAWING NUMBER	REV.
1	ISSUED FOR CONSTRUCTION	SBS	7/17/12	RSO	7/19/12	1/4"=1'-0"	7.110004-M-003	1
0	ISSUED FOR CONSTRUCTION	SBS	10/7/11	RSO	10/7/11			

DESIGNED BY	AW	9/8/11	CHECKED BY	SBS	9/14/11
DRAWN BY	JRE	9/8/11	APPROVED BY	RSO	9/14/11
DATE	9/8/11	HGA JOB NO:	7.110004	HGA ITEM NO:	

ANCHOR ROD NOTES

- ANCHOR RODS AND REINFORCING BARS, WHERE INDICATED TO BE INSTALLED USING A CHEMICAL ANCHORING SYSTEM, SHALL BE FIELD DRILLED AND INSTALLED USING THE "HILT" HIT HY 150 ANCHORING SYSTEM OR APPROVED EQUAL. THE CONTRACTOR SHALL INSTALL PER ANCHORING SYSTEM PRODUCT INSTRUCTIONS TO FULLY DEVELOP THE ANCHOR BOLTS OR REINFORCEMENT BARS. (THIS WILL INCLUDE, BUT NOT BE LIMITED TO THE DRILLED HOLE DIAMETER AND DEPTH).
- ANCHOR RODS SHALL MEET THE REQUIREMENTS OF ASTM F1554, GRADE 36 UNLESS OTHERWISE NOTED.
- ALL ANCHOR RODS AND NUTS SHALL BE HOT DIPPED GALVANIZED PER ASTM A123 WITH NUTS RETAPPED.
- ANCHOR RODS SHALL BE FURNISHED WITH HEX NUTS AND CUT WASHERS OF SPECIFICATIONS COMPATIBLE WITH THOSE OF THE THREADED SHANKS UNLESS OTHERWISE NOTED. MINIMUM WASHER SIZE AND THICKNESS SHALL COMPLY WITH THE AISC MANUAL OF STEEL CONSTRUCTION.
- ANCHOR RODS SHALL BE CLEAN AND FREE OF ANY OILS OR OTHER FOREIGN MATERIALS PRIOR TO PLACEMENT.
- MEANS SHALL BE USED TO PREVENT CONCRETE FROM CONTACTING THE PROJECTING PART OF THE ANCHOR ROD.

REFERENCE DRAWINGS

- 7.110004-C-003 ADROIT CONSTRUCTION
RVTD CNG FUELING STATION
PAVING, GRADING & DRAINAGE PLAN
- 7.110004-C-200 ADROIT CONSTRUCTION
RVTD CNG FUELING STATION
GENERAL NOTES

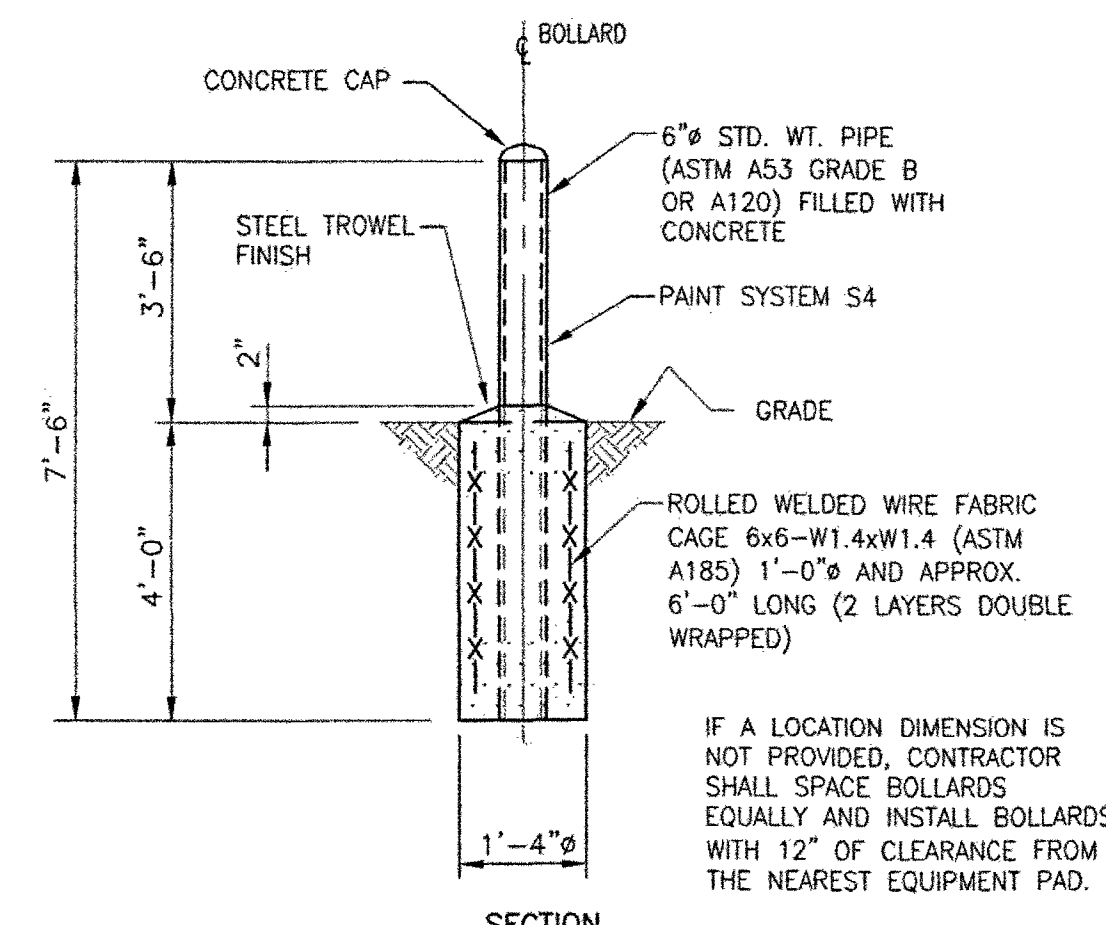

SECTION DETAIL 1
SCALE: NONE
TYPICAL BOLLARD

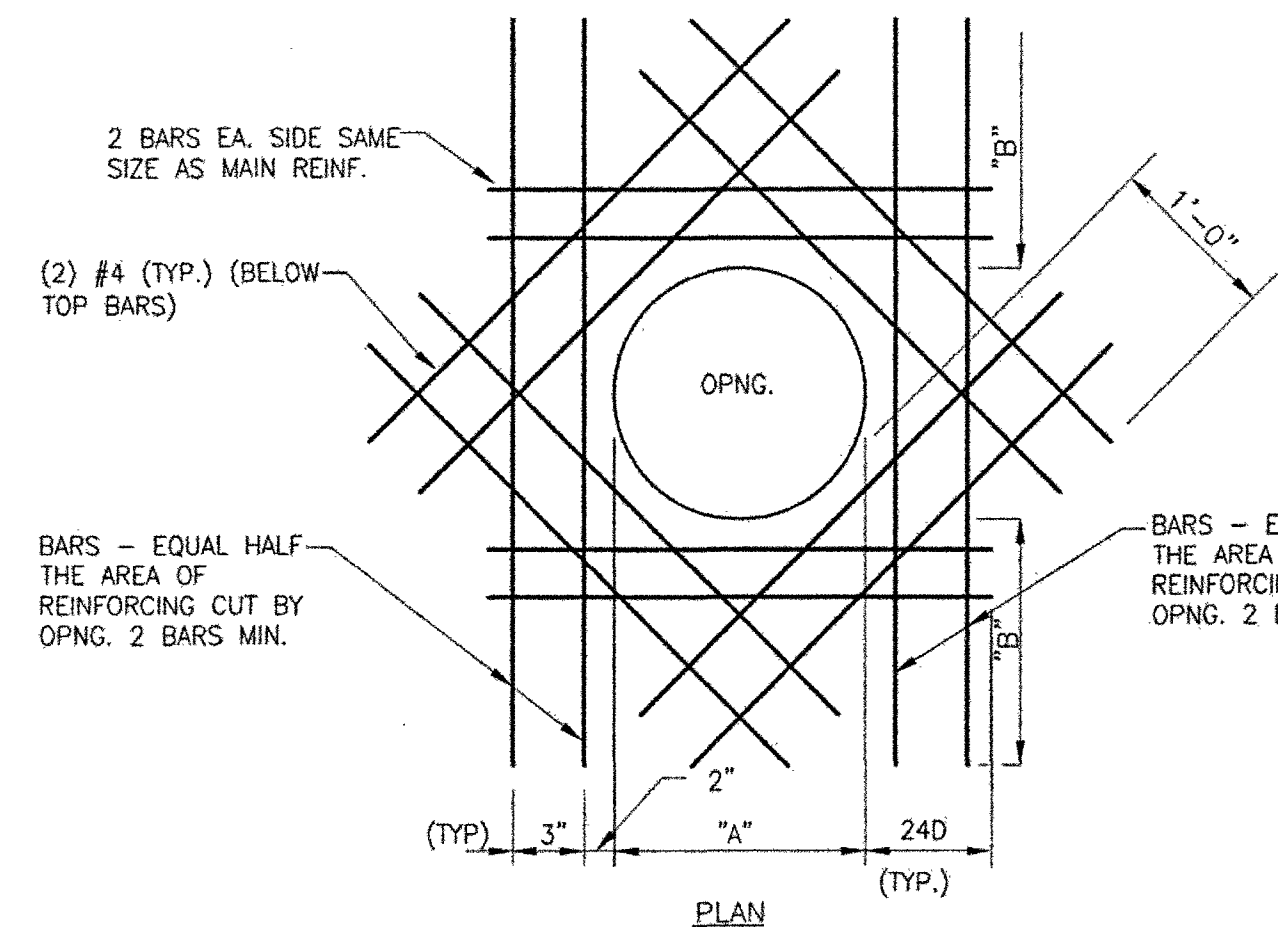

PLAN DETAIL 2
SCALE: NONE
OPENINGS THRU SLAB WHERE 'A' IS BETWEEN 1'-0\"/>

NOTE:
AT DETAILS 2 & 3
D=BAR DIAMETER

BAR SIZE	"B" DIMENSION	
	*TOP BAR	*BOT BAR
3	1'-4"	1'-0"
4	1'-9"	1'-4"
5	2'-8"	2'-1"
6	3'-10"	3'-0"

* IF "B" DIMENSION CANNOT BE OBTAINED, USE 180° HOOK

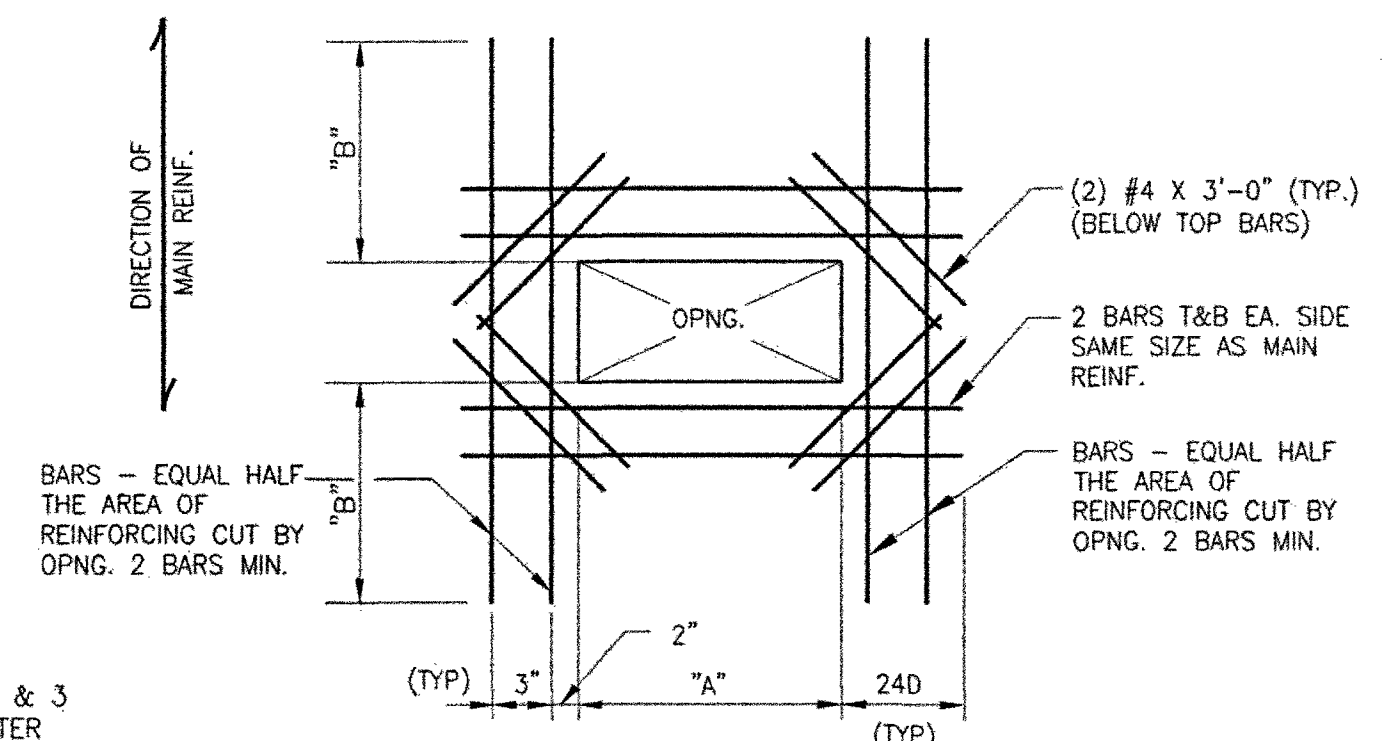

PLAN DETAIL 3
SCALE: NONE
OPENINGS THRU SLAB WHERE 'A' IS BETWEEN 1'-0\"/>

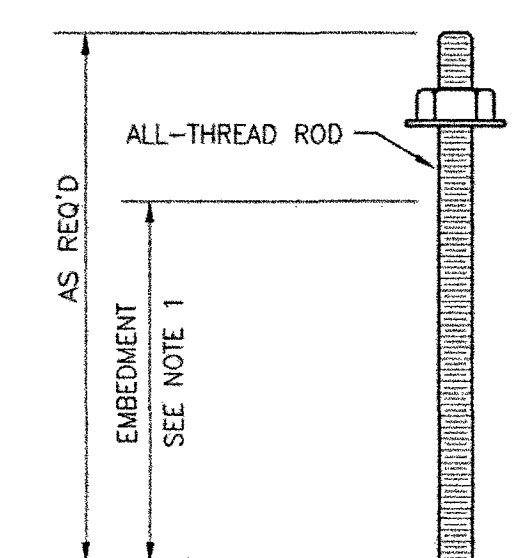

DETAIL 4
SCALE: NONE
TYPE "E" ANCHOR RODS USING CHEMICAL ANCHORING SYSTEM

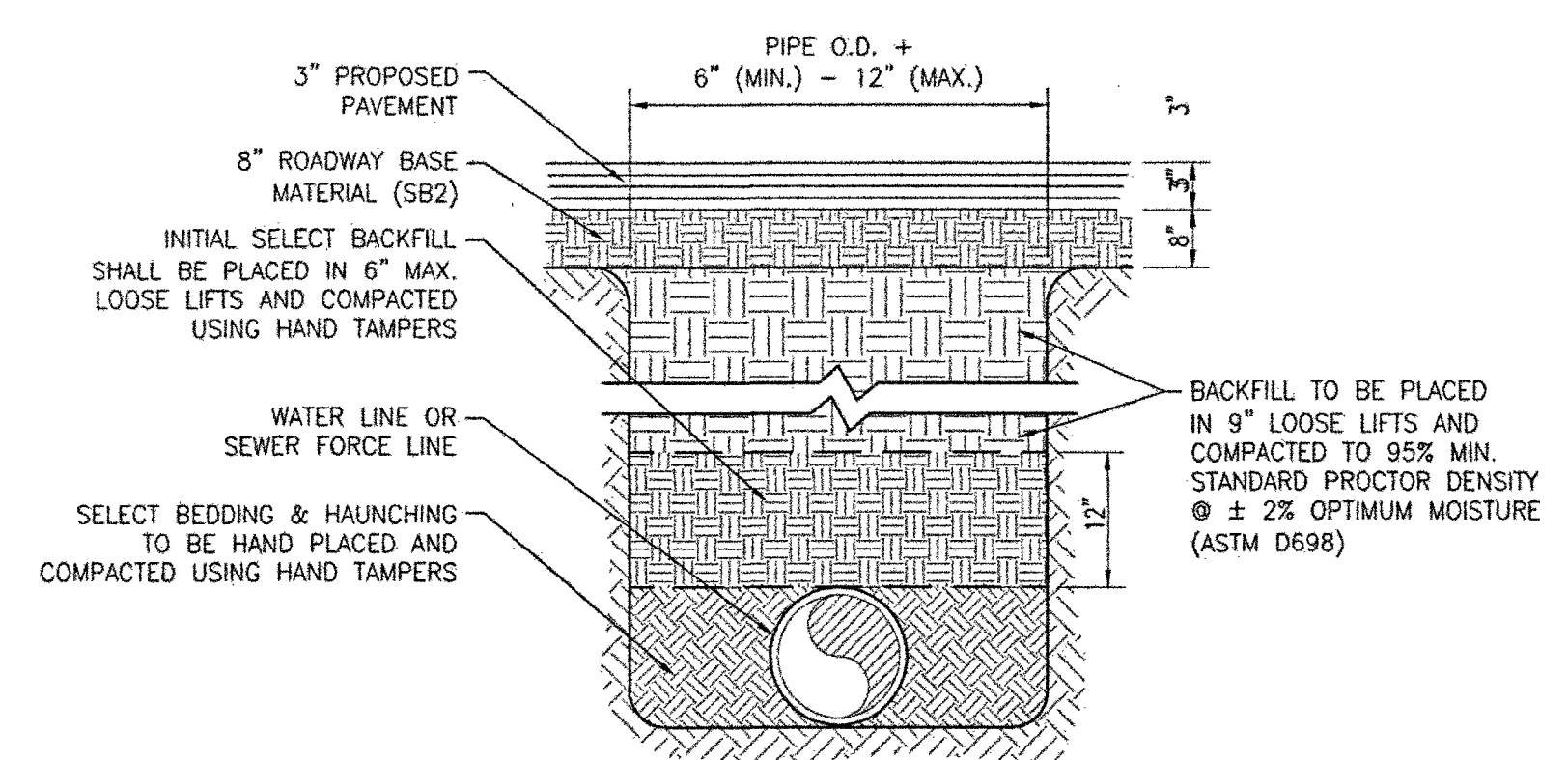

BEDDING DETAIL AT IMPROVED ASPHALT SURFACES
NOTE: THIS DETAIL SHALL APPLY TO ALL PROPOSED IMPROVED SURFACES. FOUNDATION SHALL EXTEND A MINIMUM OF 2' BEYOND BACK OF CURBS

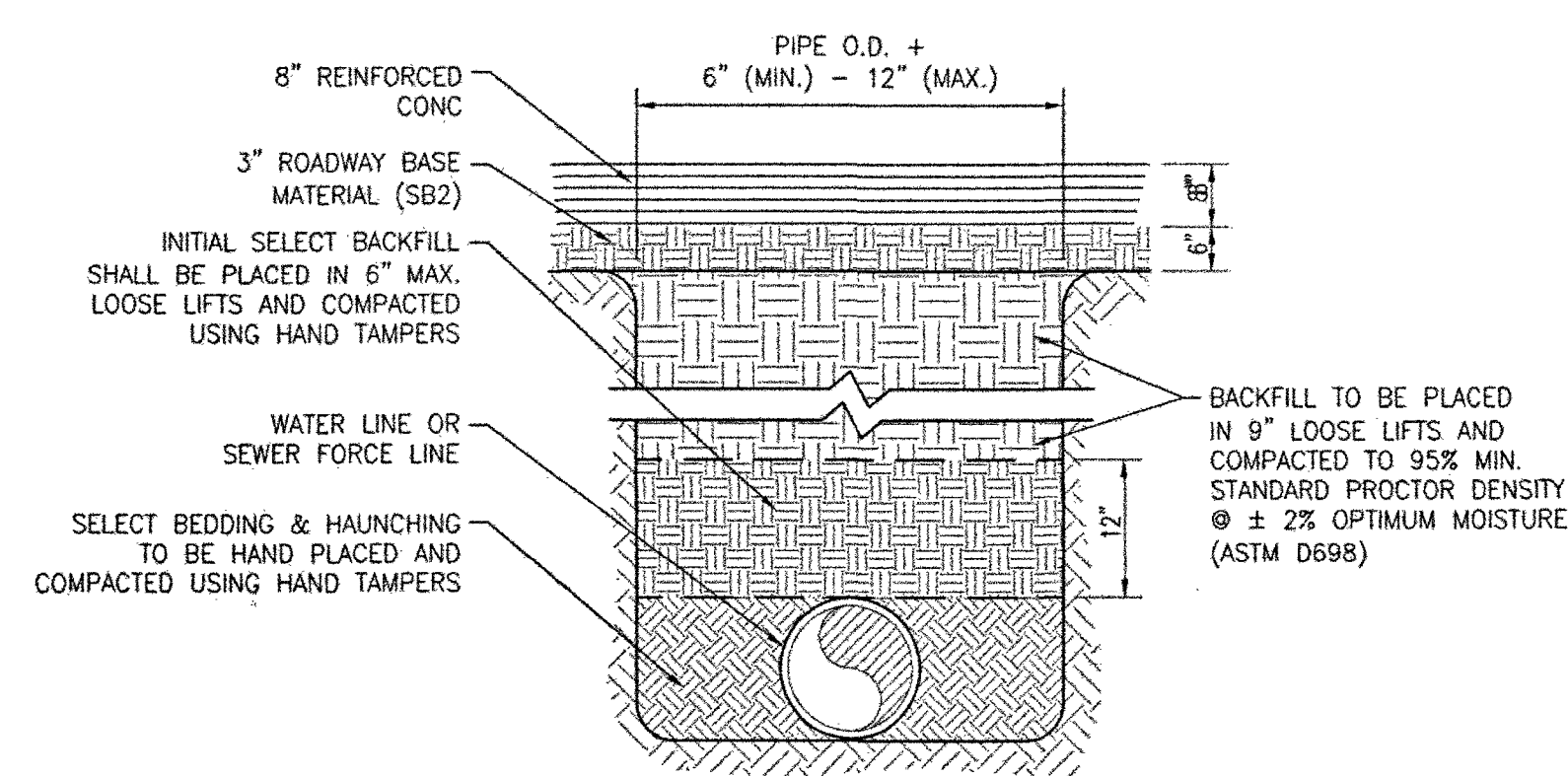

BEDDING DETAIL AT IMPROVED CONCRETE SURFACES
NOTE: THIS DETAIL SHALL APPLY TO ALL PROPOSED IMPROVED SURFACES. FOUNDATION SHALL EXTEND A MINIMUM OF 2' BEYOND BACK OF CURBS

STANDARD PIPE/CONDUIT BEDDING DETAILS
SCALE: N.T.S.

APPROVED FOR CONSTRUCTION
DATE: 10/12/11

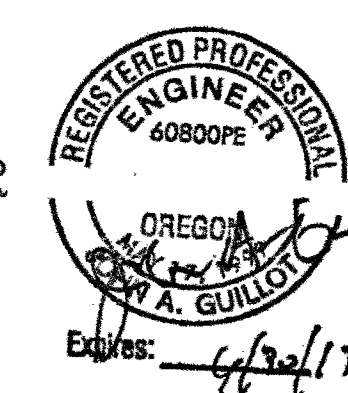

HUNT, GUILLOT & ASSOCIATES, L.L.C.
CONSULTING ENGINEERS AND PROJECT MANAGERS
P.O. BOX 580 RUSTON, LA 71273

CONFIDENTIAL
THESE DESIGNS AND DRAWINGS ARE THE EXCLUSIVE PROPERTY OF:
HUNT, GUILLOT & ASSOCIATES, RUSTON, LA
NO COPY OR REPRODUCTION MAY BE MADE WITHOUT WRITTEN APPROVAL.

ADROIT CONSTRUCTION
RVTD CNG FUELING STATION
SECTION AND DETAILS
SHEET 2

DESIGNED BY	PBW	8/23/11	CHECKED BY	CEH	9/14/11
DRAWN BY	PBW	8/23/11	APPROVED BY	RSO	9/14/11
PLOT AT 1: 1	DATE:	8/23/11	HGA JOB NO:	7110004	HGA ITEM NO:
SCALE	DRAWING NUMBER		REV.		
AS NOTED	7.110004-C-101		0		

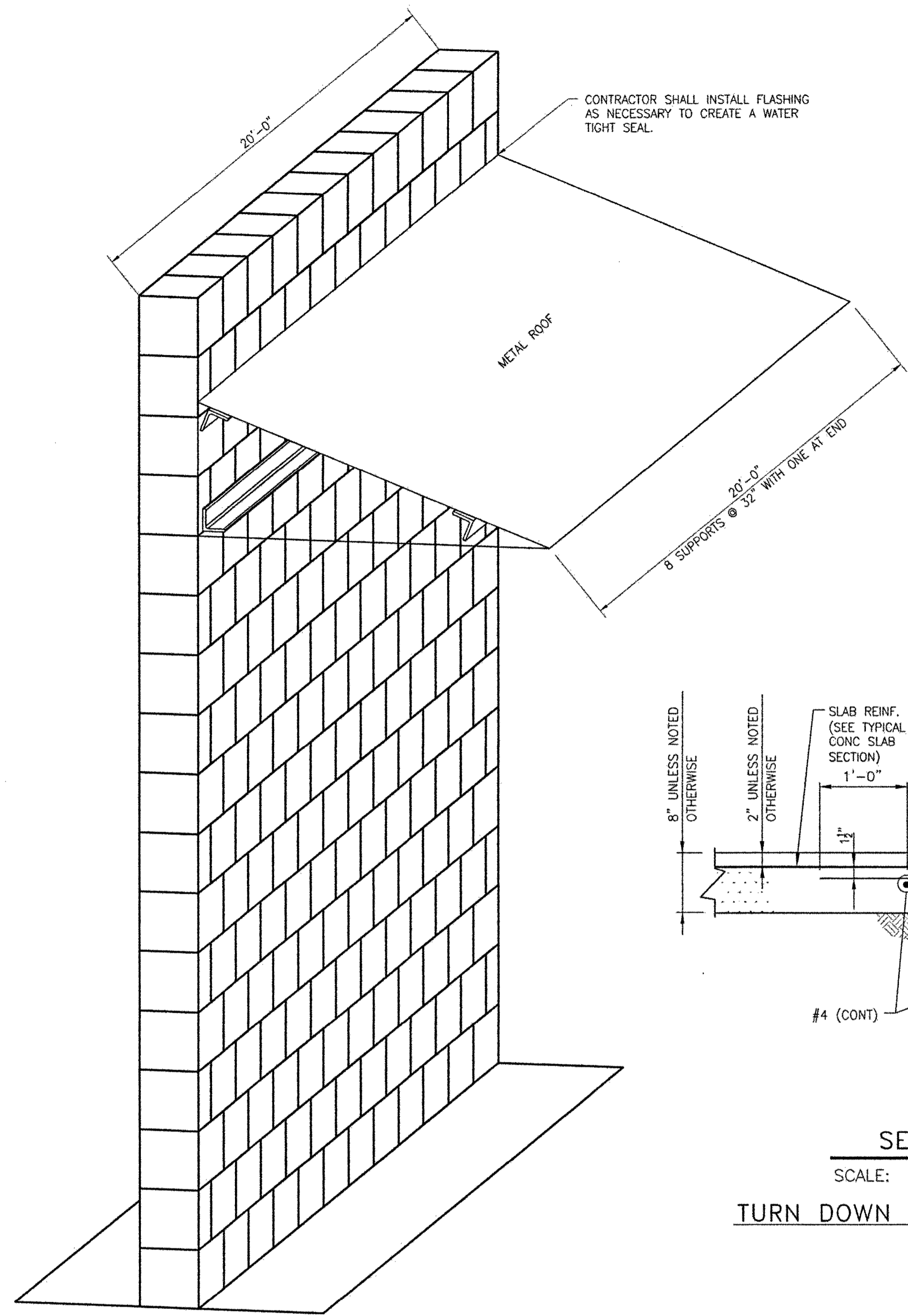

ISOMETRIC VIEW OF CMU WALL
SEE SECTION "B" THIS SHEET FOR FURTHER DETAILS

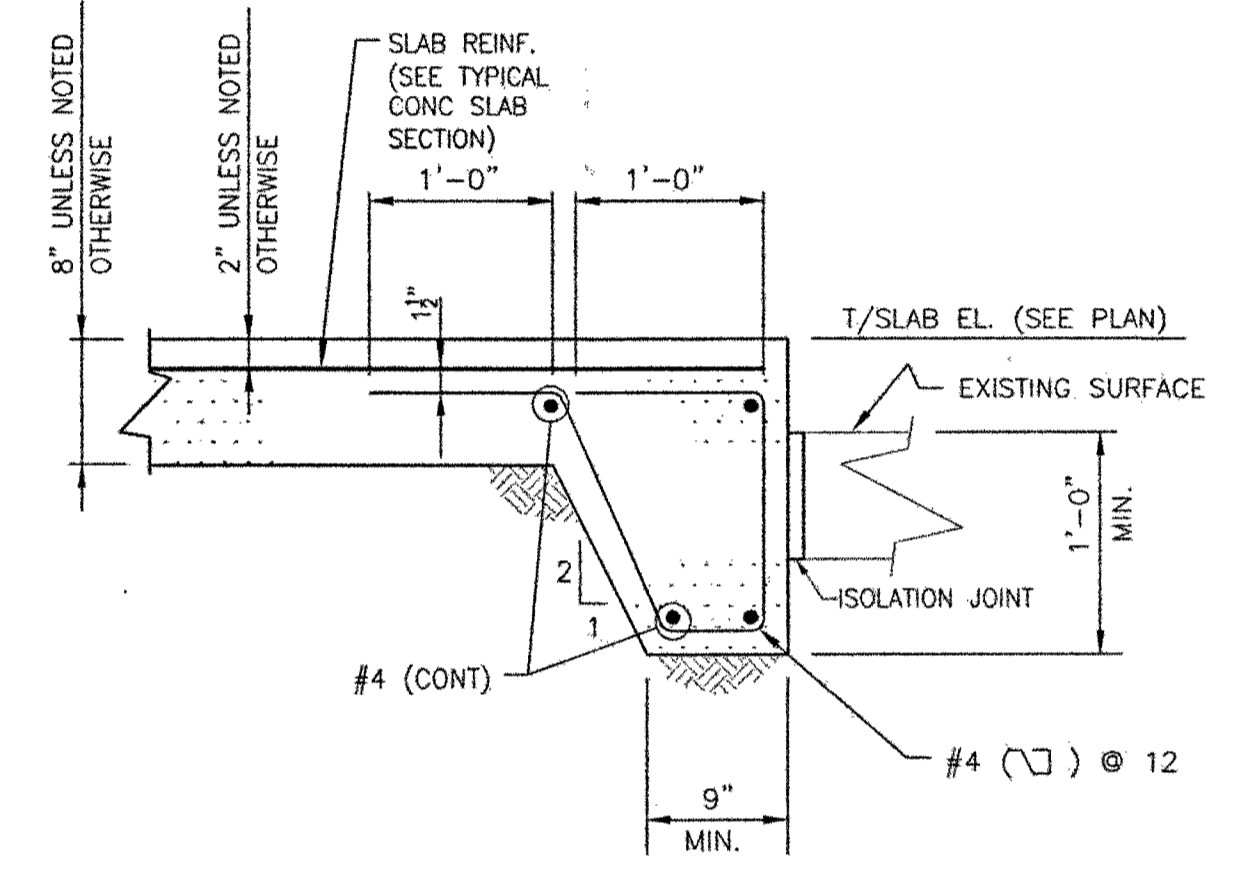

SECTION A
SCALE: 1"=1'-0"
TURN DOWN SLAB WITHOUT CURB

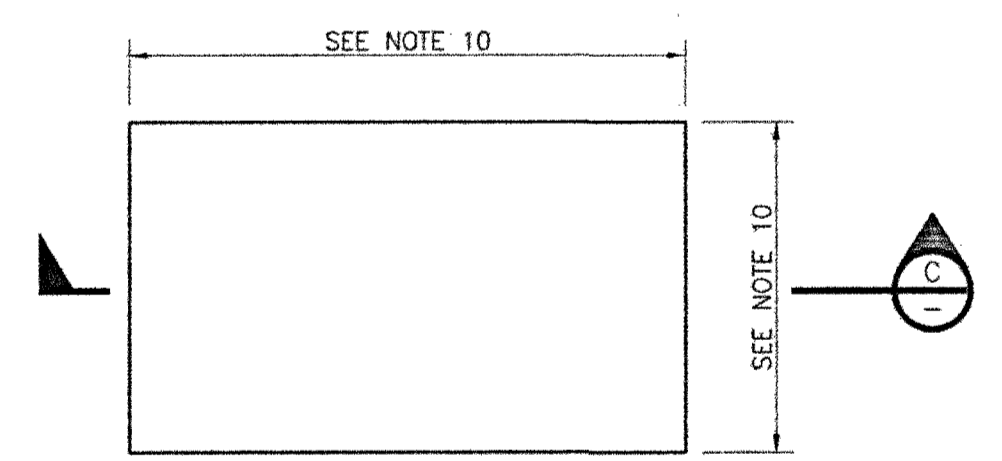

DETAIL 1
SCALE: NONE

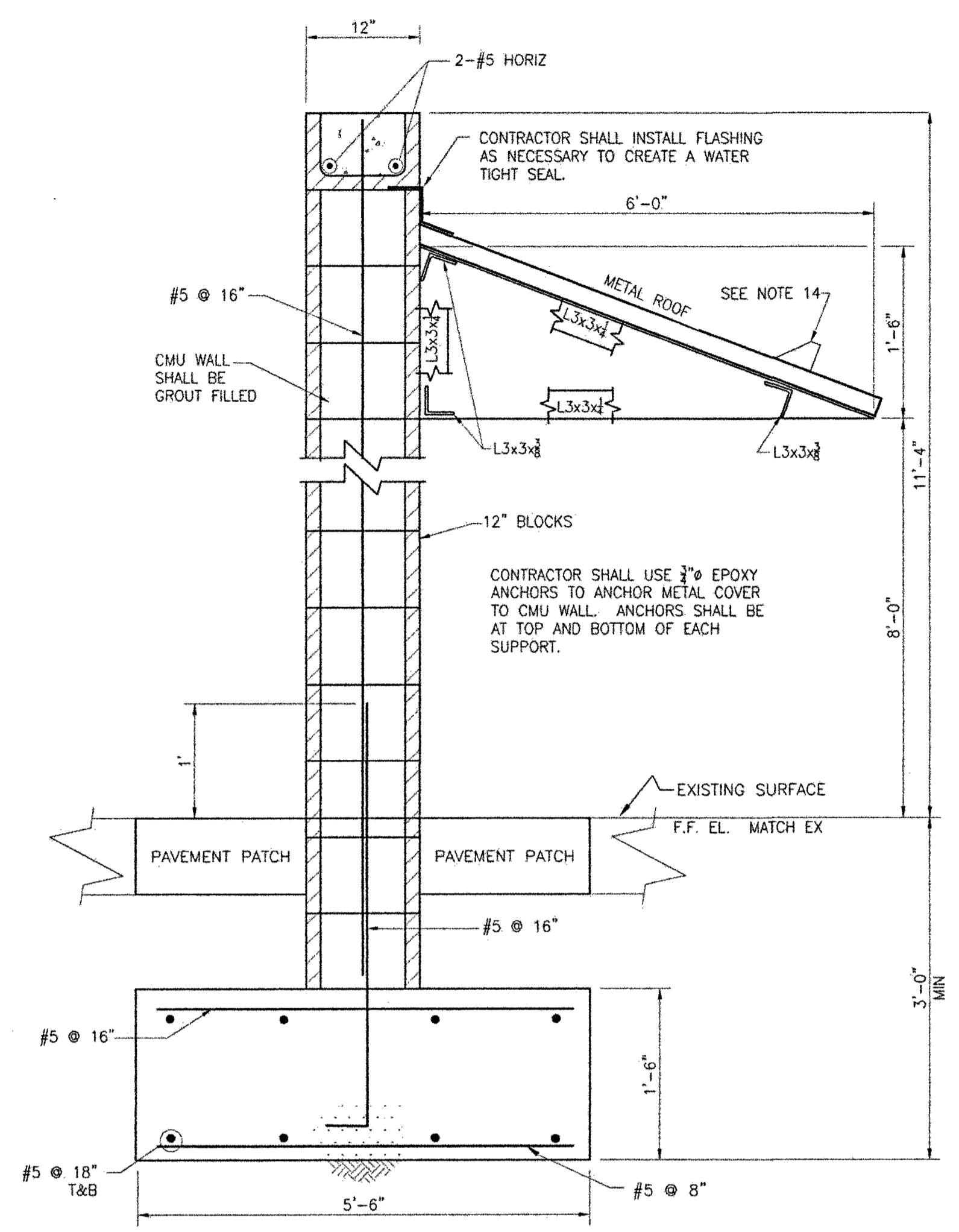

SECTION B
SCALE: 1"=1'-0"

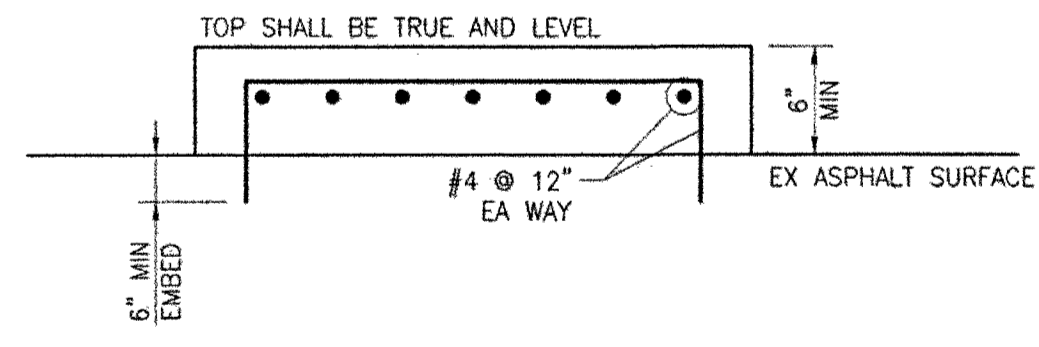

SECTION C
SCALE: NONE
TYPICAL CONCRETE SLAB SECTION

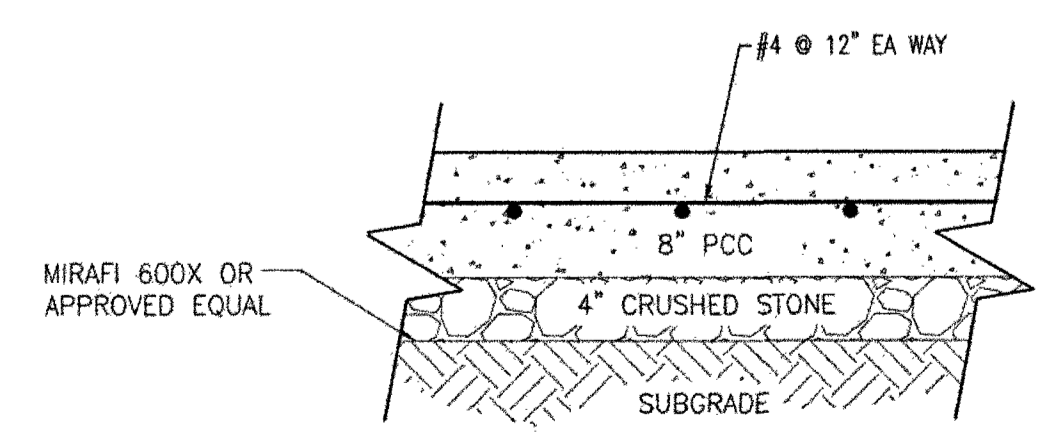

TYPICAL CONCRETE SLAB SECTION

GENERAL NOTES

- OVERALL DIMENSIONS OF ALL PADS ARE APPROXIMATE. CONTRACTOR SHALL VERIFY THAT ALL ANCHOR BOLTS SHALL BE 6" OR GREATER FROM THE NEAREST EDGE OF CONCRETE AND ADJUST PAD SIZE APPROPRIATELY.
- CONTRACTOR SHALL ANCHOR ALL EQUIPMENT.
- CONTRACTOR SHALL INSTALL ALL HOLES AND/OR PROTRUSIONS OF CONCRETE IN ACCORDANCE WITH DETAILS 2 & 3 LOCATED ON SHEET 7.110004-C-101.
- ALL NECESSARY EQUIPMENT SHALL BE ANCHORED IN ACCORDANCE WITH DETAIL 4 LOCATED ON SHEET 7.110004-C-101.
- ALL CONCRETE SHALL HAVE A COMPRESSIVE STRENGTH OF 4000 PSI.
- ALL STEEL SHALL BE 60 KSI.
- PRIOR TO ADDING ANY NEW MATERIAL THE EXISTING SOIL MUST BE COMPACTED TO 95% STANDARD PROCTOR TEST (ASTM D698). ANY SOFT AREAS FOUND SHALL BE REPLACED WITH SELECT BACKFILL.
- GEOTEXTILE FABRIC (WOVEN) SHALL BE USED UNDER ALL CRUSHED STONE.
- ALL CRUSHED STONE SHALL BE COMPACTED TO 98% OF LABORATORY MAXIMUM AS DETERMINED BY ASTM D698 METHOD C.
- CONTRACTOR SHALL SIZE PAD TO HAVE NINE (9") INCHES OF HORIZONTAL CLEARANCE ON ALL ANCHOR BOLTS. CONTRACTOR SHALL IMMEDIATELY NOTIFY THE ENGINEER SHOULD THE PAD EXTEND OUTSIDE THE PROTECTION OF THE SHOWN BOLLARDS.
- ALL ANGLED METAL SHALL BE HOT DIPPED GALVANIZED.
- METAL ROOF SHALL BE CORRUGATED TIN AND SHALL BE A COLOR APPROVED BY THE OWNER.
- ALL METAL JOINTS/CONNECTIONS SHALL BE 1/4" FILLET WELDED ALL AROUND.
- CONTRACTOR SHALL INSTALL AN ICE BREAKING DEVICE AT SIXTEEN (16) INCH MAXIMUM INCREMENTS.

MASONRY GENERAL NOTES

- REINFORCED MASONRY WORK AND MATERIALS SHALL BE IN ACCORDANCE WITH THE BUILDING CODE REQUIREMENTS FOR MASONRY STRUCTURES ACI 530/ASCE 5/TMS 402.
- REINFORCED MASONRY SHALL CONFORM TO THE SPECIFICATIONS FOR MASONRY STRUCTURES ACI 530.1/ASCE 6/TMS 602 (UNLESS NOTED IN PROJECT SPECIFICATIONS).
- PROVIDE CONCRETE MASONRY UNITS (CMU) OF NORMAL WEIGHT (125 PCF MINIMUM), GRADE N, TYPE 1, CONFORMING TO THE LATEST EDITION OF ASTM C 90. LAY UNITS IN RUNNING BOND BEAM UNLESS OTHERWISE NOTED.
- PROVIDE MASONRY MORTAR MEETING THE REQUIREMENTS OF TYPE S PER ASTM C 270. PROVIDE AGGREGATES FOR MORTAR CONFORMING TO ASTM C 404. PROVIDE MORTAR WITH A MINIMUM COMPRESSIVE STRENGTH OF 1,800 PSI AT 28 DAYS.
- PROVIDE MASONRY GROUT WITH A MINIMUM 28 DAY COMPRESSIVE STRENGTH OF 2,000 PSI TESTED IN ACCORDANCE WITH ASTM C 1019. GROUT TO MEET THE MINIMUM REQUIREMENTS SPECIFIED IN ASTM C 476.
- PROVIDE MASONRY ASSEMBLAGES WITH MINIMUM PRISM STRENGTH (F_m) OF 1,500 PSI, TESTED IN ACCORDANCE WITH ASTM C 140.
- PROVIDE CONCRETE MASONRY UNITS IN ACCORDANCE WITH ASTM C 426 LIMITS FOR DRYING SHRINKAGE OF CONCRETE BLOCKS.
- PROVIDE VERTICAL REINFORCEMENT IN CMU WALLS AS SHOWN ON DRAWINGS. FILL THE REINFORCED CELLS SOLID WITH GROUT. MAXIMUM HEIGHT OF GROUT POURS TO BE AS PER ACI 530.1, TABLE 1.15.1.
- PROVIDE HORIZONTAL JOINT REINFORCING IN WALLS AT 16 INCHES ON CENTER VERTICAL SPACINGS. JOINT REINFORCING SHALL BE HOT DIP GALVANIZED NO. 9 GAGE LADDER TYPE WITH CROSS TIES AT 16" ON CENTER, CONFORMING TO ASTM A 82. SPACE JOINT REINFORCEMENT AT 8 INCHES ON CENTER IN THE PARAPETS. LAP SPLICE ENDS A MINIMUM OF 12 INCHES AT SPLICES.
- ALIGN VERTICAL CELLS TO BE FILLED WITH GROUT TO PROVIDE CONTINUOUS UNOBSTRUCTED VERTICAL CELLS. REMOVE OVERHANGING MORTAR OR OTHER OBSTRUCTIONS AND DEBRIS FROM THE INSIDES OF SUCH CELL WALLS. PROVIDE GROUT WITH 8 INCH SLUMP AND CONSOLIDATE BY MEANS OF HAND TAMPING TO ENSURE COMPLETE FILLING OF CELLS.
- PROVIDE AN 8 INCH HIGH BOND BEAM (MINIMUM DEPTH UNLESS OTHERWISE NOTED) AT THE TOP OF ALL CMU WALLS. REINFORCE BOND BEAMS PER DETAILS. IF BOND BEAMS AT INTERSECTING WALLS MEET AT DIFFERENT ELEVATIONS, EXTEND BOND BEAMS AROUND INTERSECTING CORNER TO FIRST INTERIOR REINFORCED CELL, BUT NOT LESS THAN 4 FEET. CONSTRUCT BOND BEAMS WITH PORTLAND CEMENT GROUT 2,000 PSI MAXIMUM COMPRESSIVE STRENGTH AT 28 DAYS AND A MAXIMUM AGGREGATE SIZE OF 1/2 INCH.
- PROVIDE VERTICAL REINFORCING AT CORNERS OF CMU WALLS, AT ENDS OF WALLS, EACH SIDE OF CONTROL JOINT AND EACH SIDE OF WALL OPENINGS PER DETAILS. PROVIDE MINIMUM 1/2 INCH THROUGH-WALL CONTROL JOINTS AT 4'-0" MAXIMUM SPACING UNLESS NOTED OTHERWISE ON DRAWINGS.
- INSTALL ANCHORS, ACCESSORIES AND OTHER ITEMS TO BE BUILT IN AS WORK PROGRESSES.
- LAP SPLICE VERTICAL REINFORCING A MINIMUM OF 40 BAR DIAMETERS OR 24 INCHES, WHICHEVER IS GREATER.
- PERFORM CUTTING AND FITTING OF MASONRY WITH MASONRY SAWS PROVIDING CUT FINISHED UNITS.
- ALL CELLS SHALL BE GROUTED SOLID.
- WHEN A FOUNDATION DOWEL DOES NOT LINE UP WITH A VERTICAL CORE, DO NOT SLOPE DOWEL MORE THAN ONE HORIZONTAL TO SIX VERTICAL.
- WHEN VERTICAL DOUBLE REINFORCED CELLS ARE SPECIFIED, PROVIDE 1/2 INCH CLEARANCE FROM INSIDE FACE OF THE BLOCK MASONRY CELL OR MINIMUM OF ONE BAR DIAMETER, WHICHEVER IS GREATER. ENSURE THAT ALL VERTICAL REINFORCING STEEL IS POSITIONED AND HELD IN PLACE BY MEANS OF WIRE SPACERS.

REFERENCE DRAWINGS

- 7.110004-C-004 ADROIT CONSTRUCTION RYTD CNG FUELING STATION PAVING, GRADING & DRAINAGE PLAN
- 7.110004-C-200 ADROIT CONSTRUCTION RYTD CNG FUELING STATION GENERAL NOTES

APPROVED FOR CONSTRUCTION
DATE: 10/12/11



HUNT, GUILLOT & ASSOCIATES, L.L.C.
CONSULTING ENGINEERS AND PROJECT MANAGERS
P.O. BOX 580 RUSTON, LA 71273

CONFIDENTIAL
THESE DESIGNS AND DRAWINGS ARE THE EXCLUSIVE PROPERTY OF:
HUNT, GUILLOT & ASSOCIATES, RUSTON, LA.
NO COPY OR REPRODUCTION MAY BE MADE WITHOUT WRITTEN APPROVAL.

ADROIT CONSTRUCTION RYTD CNG FUELING STATION SECTION AND DETAILS SHEET 1

DESIGNED BY	PBW	8/23/11	CHECKED BY	CEH	9/14/11
DRAWN BY	PBW	8/23/11	APPROVED BY	RSO	8/29/11
PLOT AT 1: 1	DATE	8/23/11	HGA JOB NO:	7110004	HGA ITEM NO:
SCALE	DRAWING NUMBER		REV.		
AS NOTED	7.110004-C-100		0		

REV.	DESCRIPTION	CHK.	DATE	APP.	DATE
D	ISSUED FOR CONSTRUCTION	CEH	10/12/11	RSO	10/12/11
A	ISSUED FOR APPROVAL	CEH	9/14/11	RSO	9/14/11

NOTES:

1. ALL FENCE CONSTRUCTION AND COMPONENTS SHALL BE IN ACCORDANCE WITH THE "CHAIN LINK FENCE MANUFACTURERS INSTITUTE" (CLFMI) PRODUCT MANUAL.
2. ALL POST HOLES, EXCEPT GATE POST, SHALL BE AUGERED. DO NOT FORM.
3. PIPE LINES AND OTHER UNDERGROUND UTILITIES SHALL BE LOCATED BEFORE AUGERING.
4. BARBED WIRE SHALL BE INSTALLED, BELOW FENCE LINE, AT EXCESSIVE OPENINGS, I.E. DRAINAGE POINTS.
5. FOR CONCRETE GENERAL NOTES, SEE DRAWING STD-F-001.

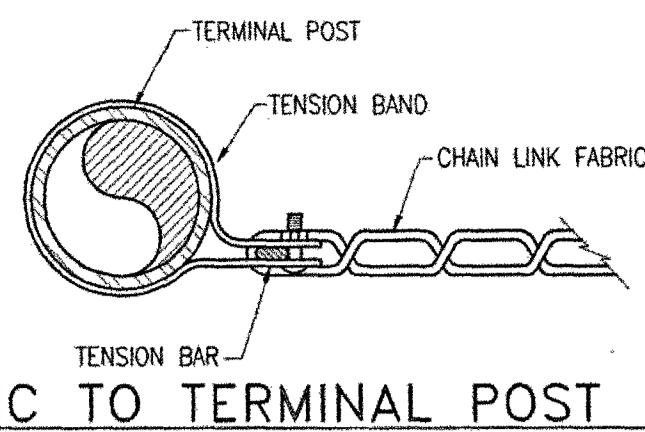

FABRIC TO TERMINAL POST

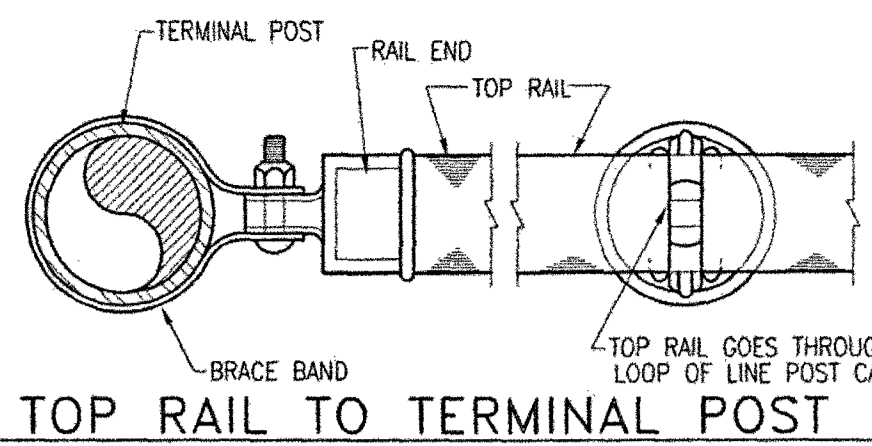

TOP RAIL TO TERMINAL POST

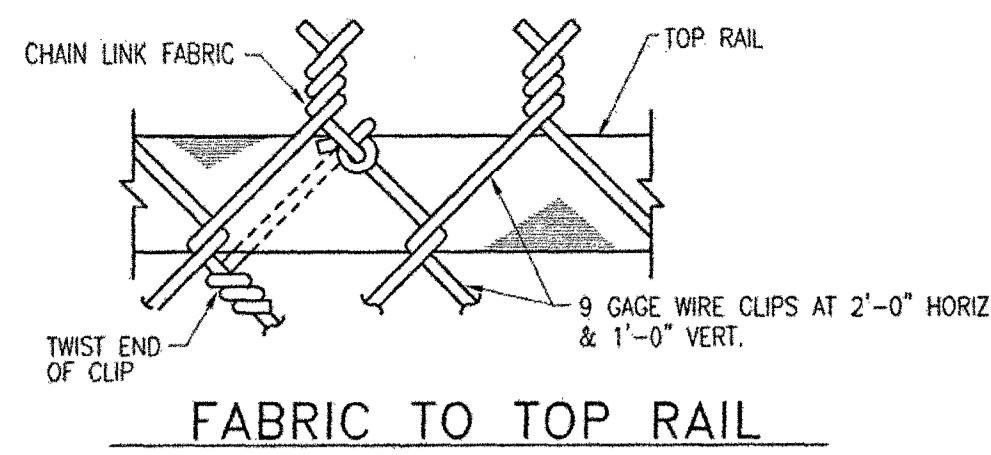

FABRIC TO TOP RAIL

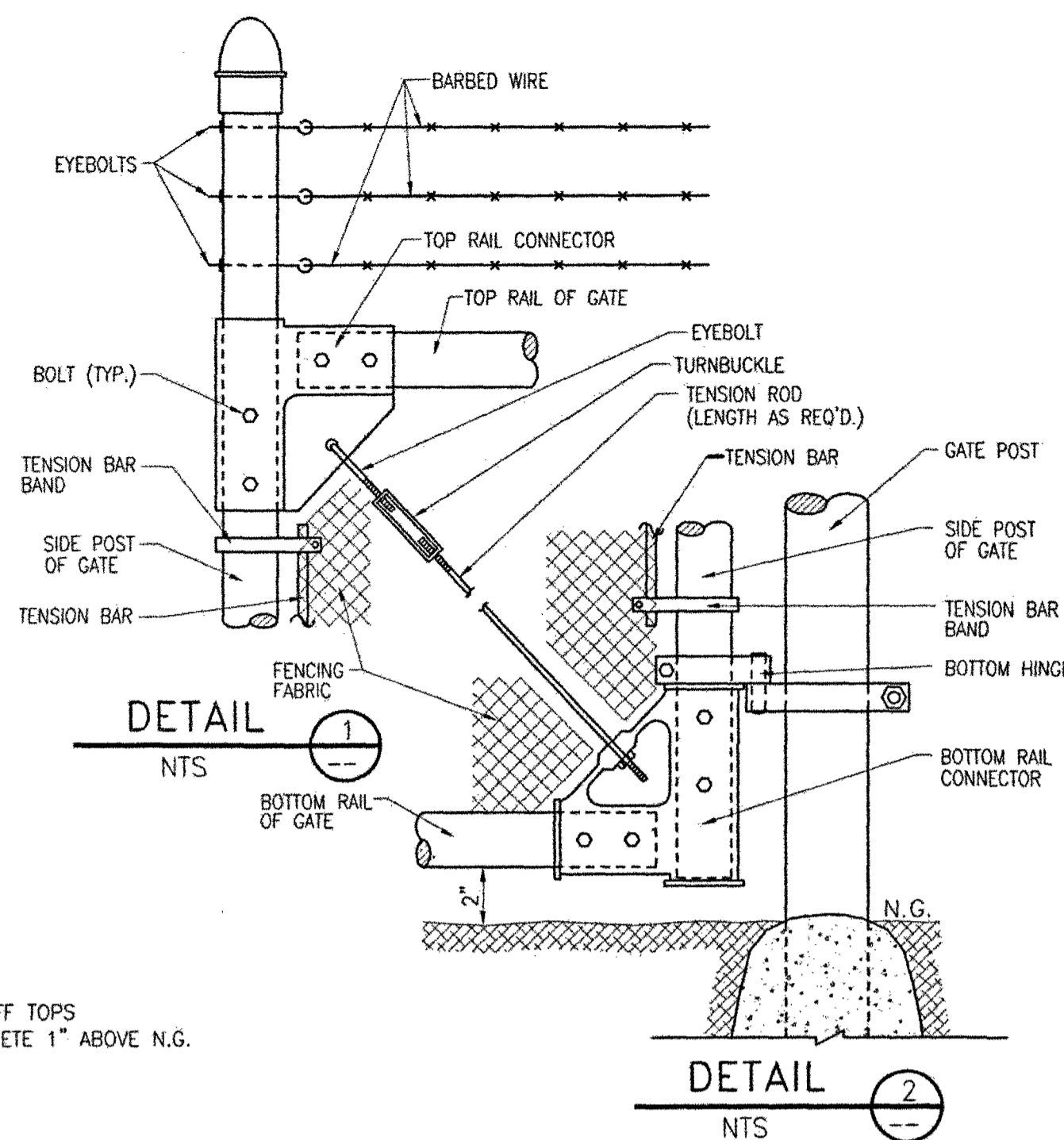

DETAIL 1 NTS

DETAIL 2 NTS

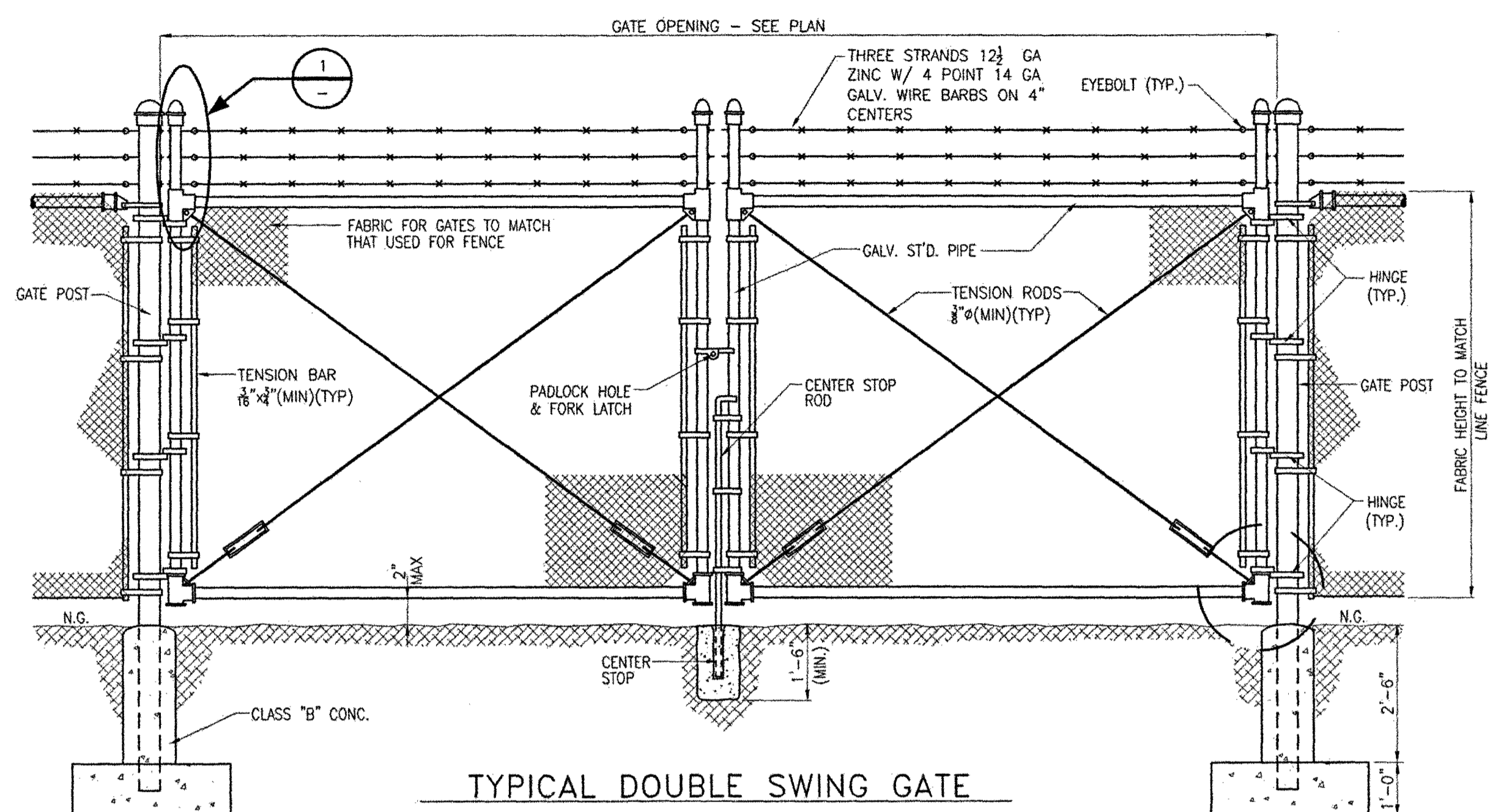

TYPICAL DOUBLE SWING GATE

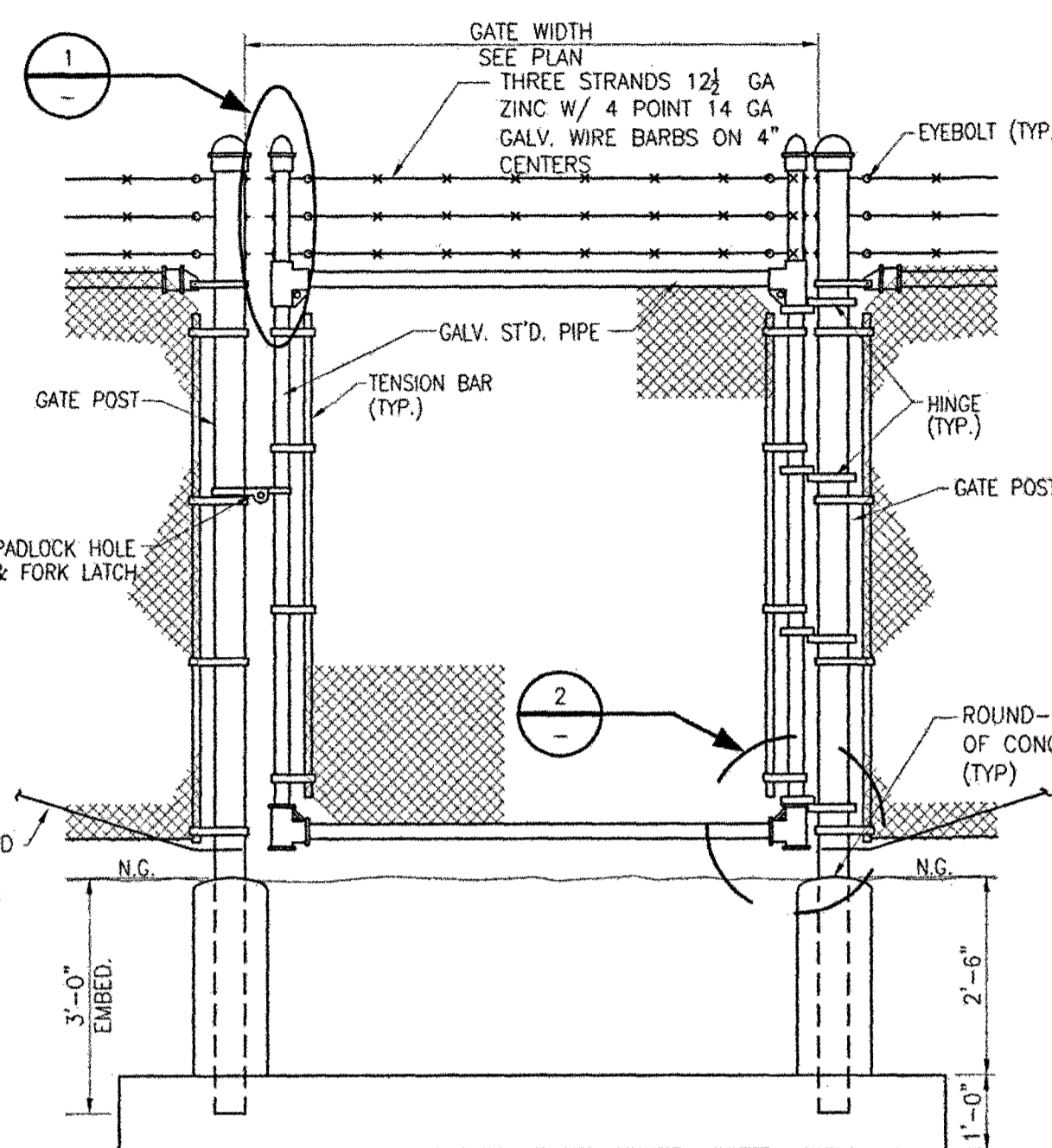

TYPICAL SINGLE SWING GATE

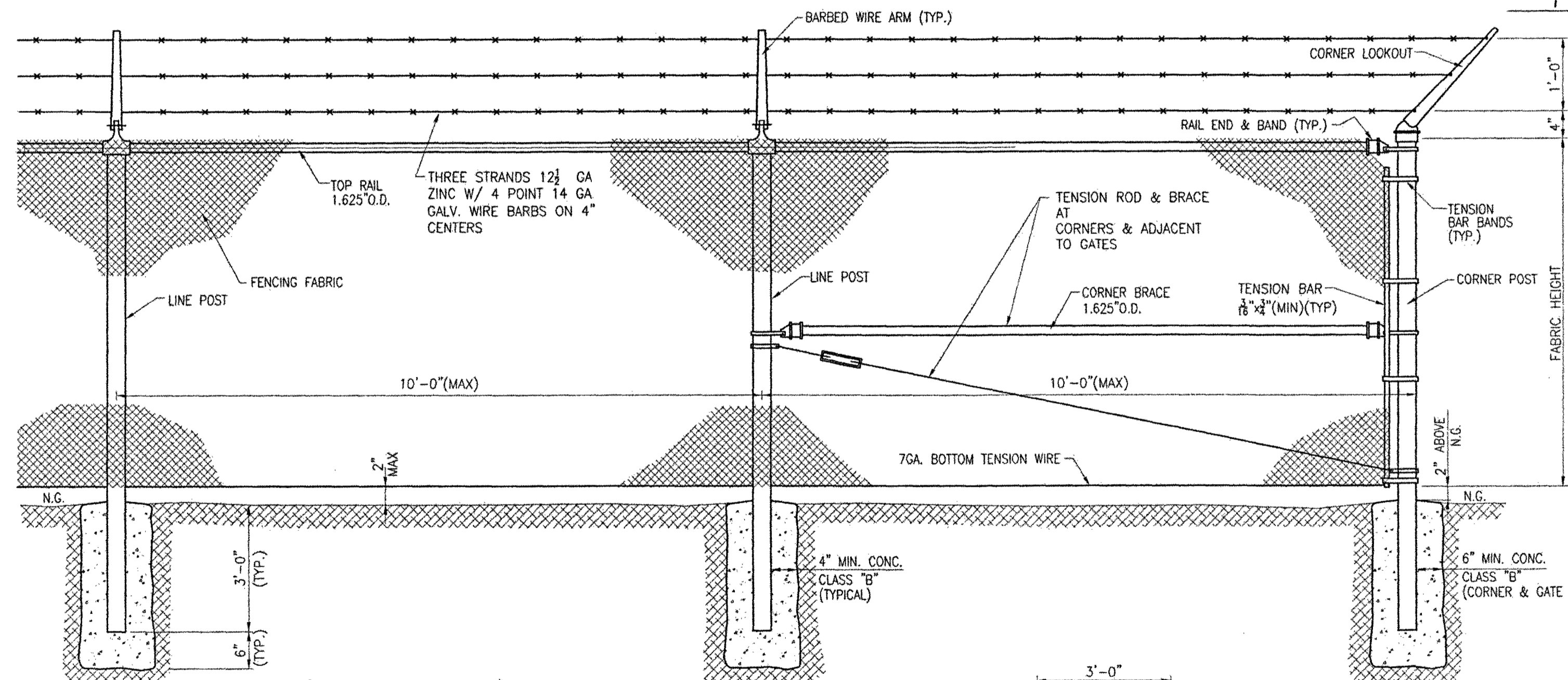

TYPICAL FENCING

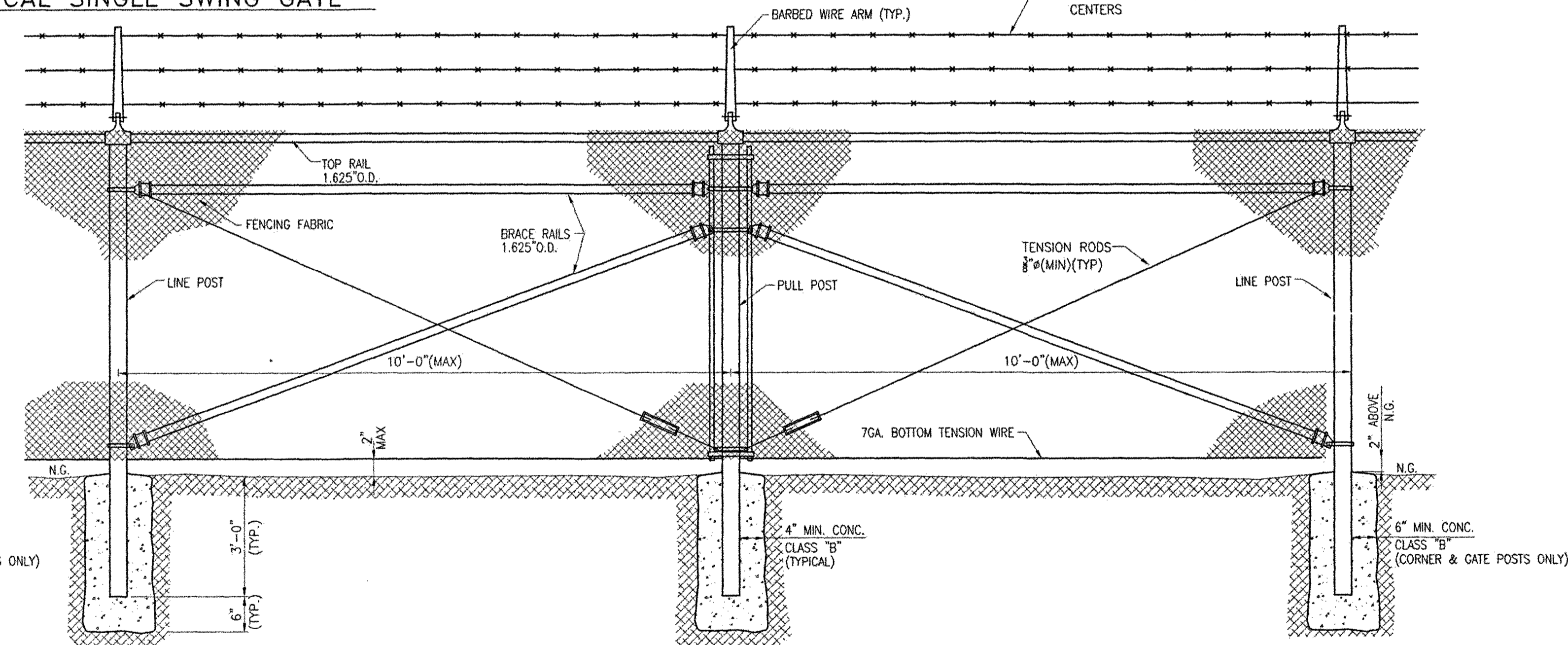

BRACE PANEL

PROVIDE BRACE PANEL WHENEVER STRAIGHT RUNS EXCEED 500 FEET

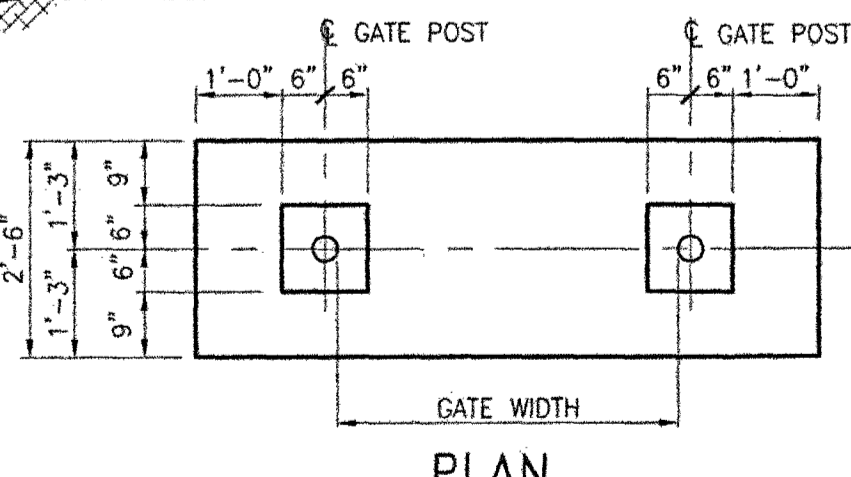

PLAN

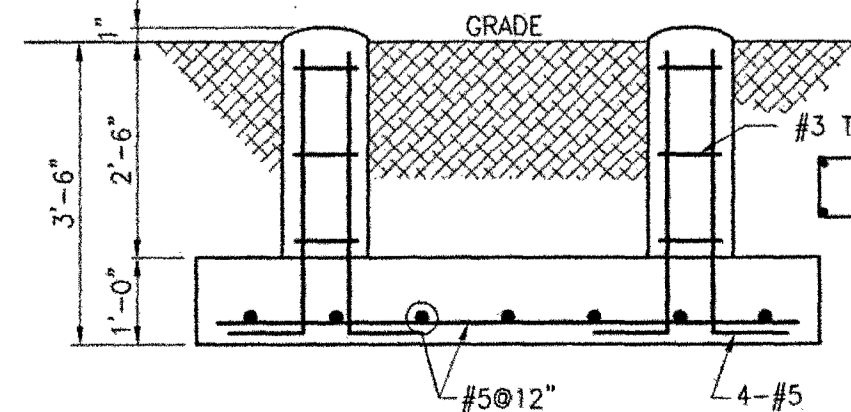

SECTION

SINGLE SWING GATE SUPPORT ONE (1) REQUIRED PER GATE

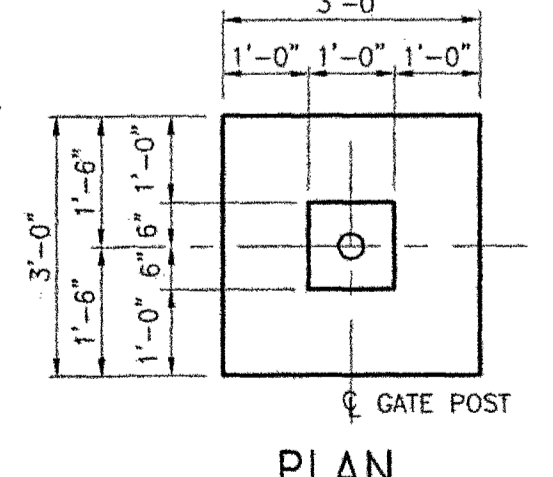

PLAN

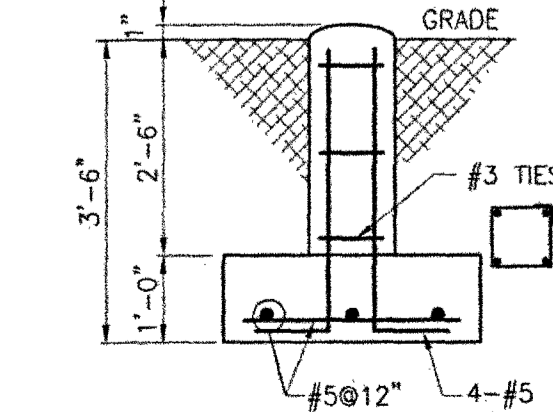

SECTION

DOUBLE GATE SUPPORT TWO (2) REQUIRED PER GATE

NOTE:
ALL HARDWARE TO BE GALVANIZED

FABRIC	HEAVY INDUSTRIAL	MEDIUM INDUSTRIAL	LIGHT INDUSTRIAL
SIZE	2"	2"	2"
GAGE	9	9	11

	6'-0" OR LESS	OVER 6'-0"
END, CORNER & PULL POST	2.375'00	2.875'00
LINE POST	1.90'00	2.375'00
GATE FRAME	1.86'00	1.90'00

	6'-0" OR LESS	OVER 6'-0"
GATE FRAME	1.86'00	1.90'00

GATE POST	GATE WIDTH FABRIC HEIGHT
4'-0" OR LESS	2.375'00
4'-0" TO 10'-0"	2.875'00
10'-0" TO 18'-0"	4.00'00

GATE POST	GATE WIDTH FABRIC HEIGHT
6'-0" TO 12'-0"	4.00'00
12'-0" TO 18'-0"	5.625'00
18'-0" TO 24'-0"	8.625'00

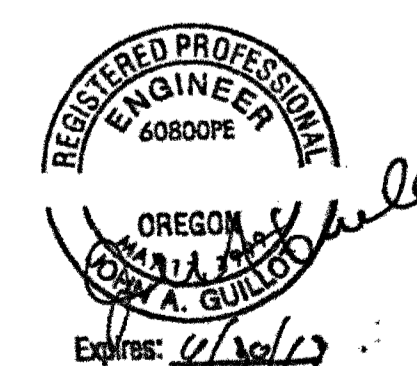

APPROVED FOR CONSTRUCTION
DATE: 10/12/11

HUNT, GUILLOT & ASSOCIATES, L.L.C.
CONSULTING ENGINEERS AND PROJECT MANAGERS
P.O. BOX 580 RUSTON, LA 71273

CONFIDENTIAL
THESE DESIGNS AND DRAWINGS ARE THE EXCLUSIVE PROPERTY OF:
HUNT, GUILLOT & ASSOCIATES, RUSTON, LA.
NO COPY OR REPRODUCTION MAY BE MADE WITHOUT WRITTEN APPROVAL.

ADROIT CONSTRUCTION
RVTD CNG FUELING STATION
FENCE DETAILS

REV.	DESCRIPTION	CHK.	DATE	APP.	DATE	SCALE	DRAWING NUMBER	REV.
0	ISSUED FOR CONSTRUCTION	CEH	10/12/11	RSO	10/12/11	1:1	7.110004-HGA ITEM NO:	
A	ISSUED FOR APPROVAL	CEH	9/14/11	RSO	9/14/11	NONE	7.110004-C-202	0

DESIGNED BY	HGA	2009	CHECKED BY	RSO	9/14/11
DRAWN BY	ADM	2009	APPROVED BY	RSO	9/14/11

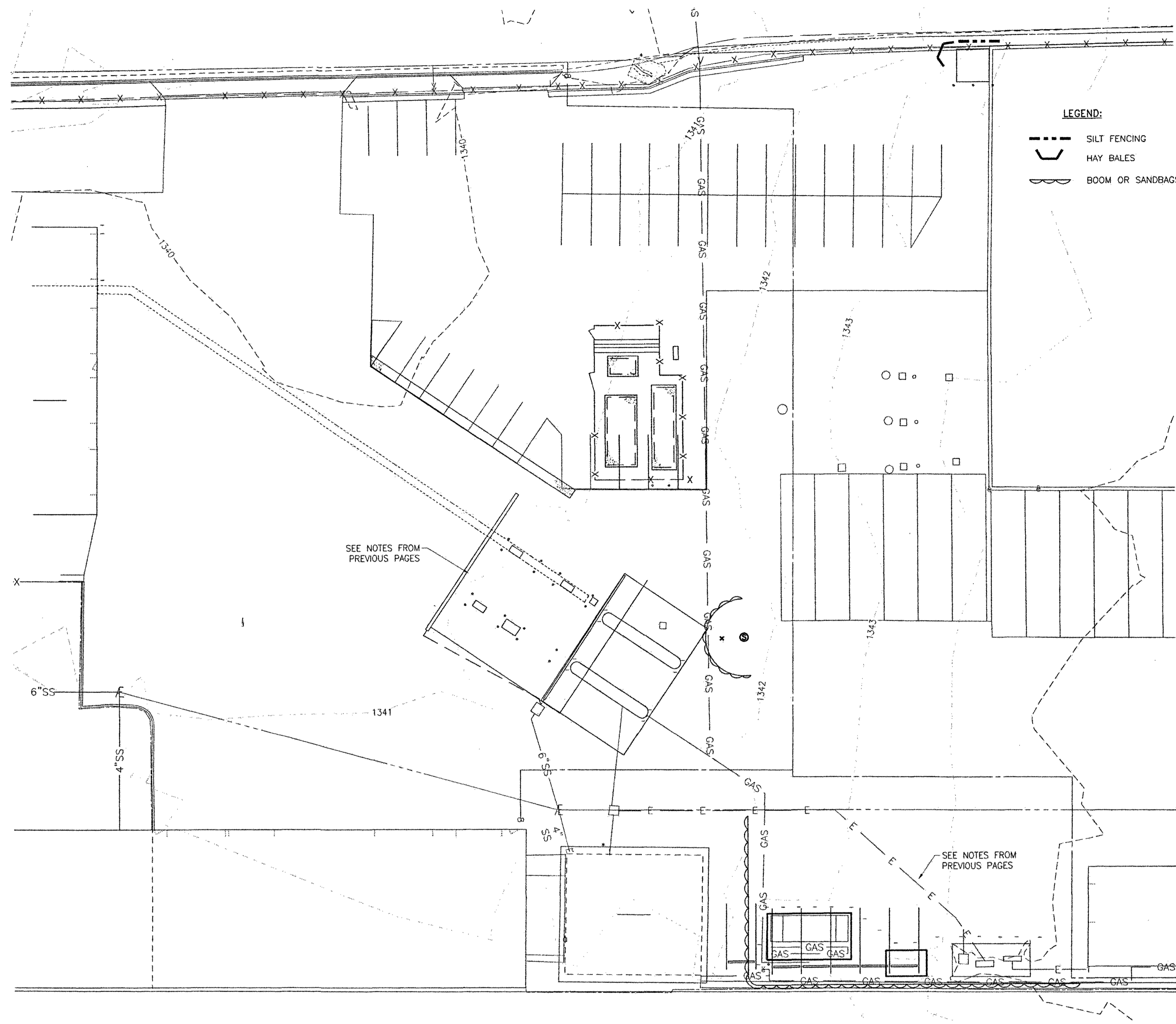

GENERAL NOTES:

1. CONTRACTOR WILL MAINTAIN ALL EROSION CONTROL MEASURES AS OUTLINED IN THE STORM WATER POLLUTION PREVENTION PLAN.
2. CONTRACTOR SHALL BE RESPONSIBLE FOR REMOVAL OF MUD TRACKED ONTO PUBLIC RIGHT-OF-WAY ON A TIMELY BASIS.
3. RIP-RAP & FILTER FABRIC SHALL BE INSTALLED AT OUTFLOWS WHERE EROSION IS ANTICIPATED. ENGINEER TO IDENTIFY THESE LOCATIONS DURING CONSTRUCTION.
4. ADDITIONAL PROTECTION: CONTRACTOR IS RESPONSIBLE FOR INSTALLING AND MAINTAINING ANY ADDITIONAL EROSION CONTROL MEASURES OTHER THAN THOSE SHOWN ON THESE PLANS TO INSURE THAT SEDIMENT IS CONFINED TO THE SITE.
5. IF THE ACTION OF VEHICLES TRAVELING OVER THE CRUSHED STONE CONSTRUCTION EXIT POINT IS NOT SUFFICIENT TO REMOVE THE MAJORITY OF DIRT AND MUD FROM THE EXITING TRAFFIC, THE CONTRACTOR SHALL PROVIDE HOSE BIBS AT THE EXIT POINT AND WASH TIRES BEFORE THE VEHICLES ENTER A PUBLIC ROAD. PROVISIONS SHALL BE MADE TO INTERCEPT THE WASH WATER AND TRAP THE SEDIMENT BEFORE IT IS CARRIED OF THE SITE.
6. IF SOIL STOCKPILING IS USED ON THE SITE, SILT FENCES SHALL BE USED TO CONTROL AND CONTAIN THE SEDIMENT.
7. TEMPORARY EROSION AND SEDIMENT CONTROL MEASURES SHALL BE REMOVED AND DISPOSED OF WITHIN 30 DAYS AFTER FINAL STABILIZATION. FINAL STABILIZATION HAS OCCURRED WHEN ALL SOIL DISTURBING ACTIVITIES ARE COMPLETED AND A UNIFORM PERENNIAL VEGETATIVE COVER WITH A DENSITY OF 70% FOR UNPAVED AREAS AND AREAS NOT COVERED BY PERMANENT STRUCTURES HAS BEEN ESTABLISHED.
8. THE EROSION CONTROL PLAN IS TO BE USED BY THE CONTRACTOR AS A MINIMUM GUIDELINE AND SHALL NOT BE USED AS A CONCLUSIVE OUTLINE. THE CONTRACTOR SHALL BE RESPONSIBLE FOR PROVIDING ADDITIONAL EROSION CONTROL METHODS AND/OR PRODUCTS NEEDED DUE TO UNFORESEEN CONSTRUCTION PROCEDURES.
9. ALL SEDIMENT SPILLED, DROPPED, WASHED OR TRACKED ONTO PUBLIC RIGHT-OF-WAY MUST BE REMOVED IN A TIMELY MANNER.
10. USE SAND BAGS, GRAVEL, BOARDS OR OTHER APPROVED METHODS TO PREVENT SEDIMENT FROM ENTERING ANY STORM DRAIN, DITCH, OR WATER COURSE.

EROSION CONTROL MAP
1"=20'-0"

APPROVED FOR CONSTRUCTION
DATE: 10/12/11

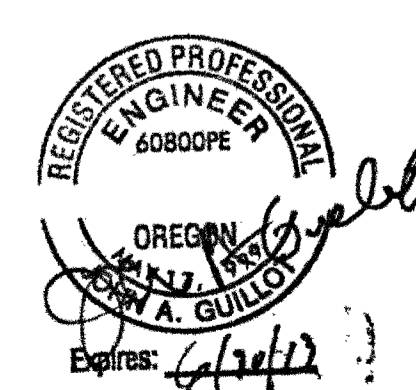

HUNT, GUILLOT & ASSOCIATES, L.L.C.
CONSULTING ENGINEERS AND PROJECT MANAGERS
P.O. BOX 580 RUSTON, LA 71273
MODEL ID:

CONFIDENTIAL
THESE DESIGNS AND DRAWINGS ARE THE EXCLUSIVE PROPERTY OF:
HUNT, GUILLOT & ASSOCIATES, RUSTON, LA.
NO COPY OR REPRODUCTION MAY BE MADE WITHOUT WRITTEN APPROVAL.

ADROIT CONSTRUCTION
RVTD CNG FUELING STATION
EROSION CONTROL DETAILS

DESIGNED BY	PBW	8/23/11	CHECKED BY	CEH	9/14/11
DRAWN BY	PBW	8/23/11	APPROVED BY	RSO	9/14/11
PLOT AT 1: 1	DATE:	8/23/11	HGA JOB NO:	7110004	HGA ITEM NO:
SCALE	DRAWING NUMBER		REV.		
AS NOTED	7.110004-C-201		0		

GENERAL SITE PLAN NOTES

- LOCATIONS, ELEVATIONS, AND DIMENSIONS OF EXISTING UTILITIES, STRUCTURES, AND OTHER FEATURES ARE SHOWN ACCORDING TO THE BEST INFORMATION AVAILABLE AT THE TIME OF PREPARATION OF THESE PLANS. THE CONTRACTOR SHALL VERIFY THE LOCATIONS, ELEVATIONS, AND DIMENSIONS OF ALL EXISTING UTILITIES, STRUCTURES, AND OTHER FEATURES, AFFECTING THIS WORK, PRIOR TO CONSTRUCTION.
- PRIOR TO THE INITIATION OF SITE CONSTRUCTION, THE CONTRACTOR SHALL VERIFY ANY EXISTING UTILITIES INCLUDING GAS, WATER, ELECTRIC, COMMUNICATIONS, CABLE TV, SANITARY, AND STORM SEWERS ON AND/OR ADJACENT TO THE SITE.
- THE CONTRACTOR SHALL EXERCISE EXTREME CAUTION IN AREAS OF BURIED UTILITIES AND SHALL CALL "ONE CALL" (811) OR UTILITY COMPANY AT LEAST 48 HOURS PRIOR TO CONSTRUCTION TO ARRANGE FOR FIELD LOCATIONS OF BURIED UTILITIES.
- THE CONTRACTOR IS RESPONSIBLE FOR REPAIRING ANY DAMAGE TO EXISTING FACILITIES, ABOVE OR BELOW GROUND THAT MAY OCCUR AS A RESULT OF THE WORK PERFORMED BY THE CONTRACTOR OR SUBCONTRACTORS.
- IT IS THE CONTRACTOR'S RESPONSIBILITY TO BECOME FAMILIAR WITH THE PERMIT AND INSPECTION REQUIREMENTS SPECIFIED BY THE VARIOUS GOVERNMENTAL AGENCIES AND THE ENGINEER.
- SAFETY:
 - DURING THE CONSTRUCTION AND/OR MAINTENANCE OF THIS PROJECT, ALL SAFETY REGULATIONS ARE TO BE ENFORCED. THE CONTRACTOR, OR HIS REPRESENTATIVE SHALL BE RESPONSIBLE FOR THE CONTROL AND SAFETY OF THE TRAVELING PUBLIC AND THE SAFETY OF HIS/HER PERSONNEL.
 - LABOR SAFETY REGULATIONS SHALL CONFORM TO THE PROVISIONS SET FORTH BY OSHA IN THE FEDERAL REGISTER OF THE DEPARTMENT OF TRANSPORTATION.
 - THE MINIMUM STANDARDS AS SET FOR THE DOTD SHALL BE FOLLOWED IN THE DESIGN, APPLICATION, INSTALLATION, MAINTENANCE, AND REMOVAL OF ALL TRAFFIC CONTROL DEVICES, WARNING DEVICES, AND BARRIERS NECESSARY TO PROTECT THE PUBLIC AND CONSTRUCTION PERSONNEL FROM HAZARDS WITHIN THE PROJECT LIMITS.
 - ALL TRAFFIC CONTROL MARKINGS AND DEVICES SHALL CONFORM TO THE PROVISIONS SET FORTH IN THE MANUAL ON UNIFORM TRAFFIC CONTROL DEVICES PREPARED BY THE U.S. DEPARTMENT OF TRANSPORTATION FEDERAL HIGHWAY ADMINISTRATION.
 - ALL SUBSURFACE CONSTRUCTION SHALL COMPLY WITH THE "TRENCH SAFETY ACT", THE CONTRACTOR SHALL INSURE THAT THE METHOD OF TRENCH PROTECTION AND CONSTRUCTION IS IN COMPLIANCE WITH THE OCCUPATIONAL SAFETY AND HEALTH ADMINISTRATION (OSHA) REGULATIONS.
- IT SHALL BE THE SOLE RESPONSIBILITY OF THE CONTRACTOR TO COMPLY WITH AND ENFORCE ALL APPLICABLE SAFETY REGULATIONS. THE ABOVE INFORMATION HAS BEEN PROVIDED FOR THE CONTRACTOR'S INFORMATION ONLY AND DOES NOT IMPLY THAT THE OWNER OR ENGINEER WILL INSPECT AND/OR ENFORCE SAFETY REGULATIONS.
- A QUALIFIED TESTING LABORATORY SHALL PERFORM ALL TESTING NECESSARY TO ASSURE COMPLIANCE OF THE IN-PLACE MATERIALS AS REQUIRED BY THE PLANS, THE VARIOUS AGENCIES AND PERMIT CONDITIONS. SHOULD ANY RETESTING BE REQUIRED DUE TO THE FAILURE OF ANY TESTS TO MEET THE REQUIREMENTS, THE CONTRACTOR WILL BEAR ALL COSTS OF SAID RETESTING.
- IN ACCORDANCE WITH GENERALLY ACCEPTED CONSTRUCTION PRACTICES, THE CONTRACTOR WILL BE SOLELY AND COMPLETELY RESPONSIBLE FOR CONDITIONS OF THE JOB SITE, INCLUDING SAFETY OF ALL PERSONS AND PROPERTY DURING PERFORMANCE OF THE WORK. THIS REQUIREMENT WILL APPLY CONTINUOUSLY AND NOT LIMITED TO NORMAL WORKING HOURS.
- THE CONTRACTOR SHALL THOROUGHLY REVIEW ALL PLANS AND SPECIFICATIONS, SHALL PREPARE DETAILED MATERIAL QUANTITIES AND COSTS ACCORDINGLY BEFORE SUBMITTING HIS BID. ANY WORK CONSTRUCTION MATERIALS, FITTINGS, AND APPURTENANCES REQUIRED BY THE PLANS AND SPECIFICATIONS, (INCLUDING FITTINGS AND MATERIAL TAKE-OFF ITEM POINTS) AND NOT OTHERWISE IDENTIFIED AS A PAY ITEM OR A MATERIAL TAKE-OFF ITEM, SHALL BE DEEMED INCIDENTAL TO CONSTRUCTION AND SHALL BE PREFORMED, SUPPLIED AND INSTALLED AT NO ADDITIONAL PAY.
- THE CONTRACTOR SHALL PROVIDE TEMPORARY UTILITIES SUCH AS ELECTRICITY AND WATER.
- IMPORTED BACKFILL SHALL BE PAID FOR BASED ON THE ACTUAL VOLUME OF CUBIC YARDS INSTALLED IN THE TRENCH OR PAVEMENT SECTION LIMITS SHOWN IN THE PLANS AS GIVEN IN THE OREGON STANDARD SPECIFICATIONS FOR CONSTRUCTION, PER THE UNIT RATE IN THE CONTRACTOR'S BID PROPOSAL. IF MEASUREMENT IS CALCULATED BY VEHICULAR MEASUREMENT, THE AMOUNT SHALL BE ADJUSTED BY DIVIDING THE MEASURED QUANTITY BY 1.30 SHRINKAGE FACTOR.
- THE CONTRACTOR SHALL RESTORE IN KIND EXISTING LANDSCAPING DISTURBED DUE TO CONSTRUCTION. THIS SHALL INCLUDE, BUT NOT LIMITED TO TREES, SHRUBS, FLOWERS, SOLID SOD, BEDDING MATERIAL(SOIL) AND SPRINKLER SYSTEM APPURTENANCES. DISTURBED AREAS MUST BE SEEDED AND FERTILIZED UNLESS NOTED AS SOLID SOD ON THESE PLANS. FINAL PAYMENT FOR THIS ITEM WILL BE UPON NO EROSION AND THE ESTABLISHMENT OF AN ADEQUATE STAND OF PERMANENT GRASS AS DEEMED SATISFACTORY BY THE OWNER.
- THE CONTRACTOR SHALL MAINTAIN WATER AND SEWER SERVICE (IF APPLICABLE) AT ALL TIMES DURING CONSTRUCTION.
- THE CONTRACTOR SHALL BE RESPONSIBLE FOR SECURING THE NECESSARY CITY, STATE AND PARISH PERMITS FROM CONTROLLING AGENCIES REQUIRED FOR CONSTRUCTION OF THIS PROJECT. THE PERMIT SHALL BE OBTAINED IN THE NAME OF THE OWNER.
- THE CONTRACTOR IS RESPONSIBLE FOR REESTABLISHING EXISTING DRAINAGE CONDITIONS.
- THE CONTRACTOR MUST MAINTAIN LOCAL TRAFFIC ALONG STREETS AND ACROSS INTERSECTIONS. THE CONTRACTOR SHALL BE INSTALL TEMPORARY TRAFFIC MAINTENANCE AGGREGATE FOR LOCAL TRAFFIC. THE CONTRACTOR SHALL BE RESPONSIBLE FOR PLACEMENT OF SIGNS AND BARRICADES AS REQUIRED UNTIL COMPLETION OF CONSTRUCTION TO INSURE SAFE WORKING CONDITIONS FOR CONSTRUCTION PERSONNEL AS WELL AS SAFE DRIVING CONDITIONS FOR THE GENERAL PUBLIC. THE USE OF FLAGMEN SHALL BE UTILIZED AT THE DISCRETION OF THE CONTRACTOR. TRAFFIC SHALL BE MAINTAINED IN ACCORDANCE WITH ALL CURRENT REGULATIONS SPECIFIED BY THE MANUAL OF UNIFORM TRAFFIC CONTROL DEVICES (MUTCD).
- THE CONTRACTOR SHALL BE RESPONSIBLE FOR LAYOUT AND ALIGNMENT OF THE PROPOSED PROJECT.
- CONTRACTOR SHALL BE RESPONSIBLE FOR THE DEVELOPMENT AND DEPLOYMENT OF A TEMPORARY EROSION CONTROL PLAN THAT MEETS ALL APPLICABLE LOCAL, STATE & FEDERAL GOVERNMENT REGULATION. PLAN SHALL BE SUBMITTED TO ENGINEER FOR APPROVAL PRIOR TO START OF CONSTRUCTION.
- ALL TRENCH AND OTHER EXCAVATIONS SHALL BE IN STRICT ACCORDANCE WITH OSHA REGULATIONS AND APPLICABLE LOCAL CODES AND ORDINANCES.
- CONTRACTOR SHALL MAINTAIN ONE SET OF "RECORD DRAWINGS" AT THE PROJECT SITE AT ALL TIMES. ALL LOCATIONS OF UTILITIES (INCLUDING SERVICE LINES), ENGINEER APPROVED CHANGES AND ANY DEVIATIONS FROM THE PLANS SHALL BE CLEARLY MARKED ON THE DRAWINGS. CONTRACTOR SHALL DELIVER TO ENGINEER WHEN UTILITY IMPROVEMENT INSTALLATIONS ARE COMPLETE. ENGINEER SHALL PROVIDE ONE FINAL COPY OF THE RECORD DRAWING TO ADROIT CONSTRUCTION FOR OWNER'S PERMANENT RECORDS.
- CONTRACTOR SHALL PERFORM ALL WORK AS REQUIRED TO PROTECT THE ADJOINING PROPERTY, STREETS, SIDEWALKS, ETC. FROM DAMAGE.
- CONTRACTOR SHALL NOTIFY ENGINEER, OWNER, AND LOCAL MUNICIPALITY (WATER & SEWER DEPT, ELECTRICAL DEPT., AS APPROPRIATE) 48 HOURS PRIOR TO CONSTRUCTION, TESTING AND OTHER OPERATIONS AS REQUIRED BY NOTES ON PLANS. CONTRACTOR IS SPECIFICALLY CAUTIONED THAT FAILURE TO NOTIFY ENGINEER, AND/OR OWNER MAY RESULT IN UNCOVERING AND/OR RE-INSTALLING AND/OR REPLACEMENT OF UTILITY IMPROVEMENTS TO THE ENGINEER'S AND OWNER'S SATISFACTION AT CONTRACTOR'S COST (NO COST TO OWNER OR ENGINEER). CONTRACTOR'S START OF WORK AT JOB SITE MEANS CONTRACTOR HAS READ AND AGREED TO THESE CONDITIONS.

GENERAL GRADING NOTES:

- SELECT FILL MATERIAL PLACED DURING CONSTRUCTION SHALL MEET REQUIREMENTS FOR TYPE OF MATERIAL, PLACEMENT AND COMPACTION SPECIFIED IN THE DOTD STANDARD SPECIFICATIONS.
- THE ENTIRE CONSTRUCTION AREA SHALL BE STRIPPED OF ORGANIC MATERIAL AND PROOF ROLLED PRIOR TO PLACEMENT OF FILL. AREAS OF UNSTABLE SOIL SHALL BE REMOVED AND REPLACED BY THE ENGINEER. EXCAVATED MATERIAL NOT USED FOR FILL ON SITE SHALL BE TESTED FOR CONTAMINATION AS REQUESTED BY ENGINEER. CONTAMINATED MATERIAL SHALL BE PROPERLY DISPOSED OF AT A PERMITTED LANDFILL.
- SELECT FILL SHALL BE PLACED ON PREPARED SUBGRADE IN 8" LOOSE LIFTS AND COMPACTED TO 95% STANDARD PROCTOR DENSITY OR AS DIRECTED BY PROJECT ENGINEER. COMPACTION TESTS WILL BE REQUIRED FOR EACH LIFT.
- THE CONTRACTOR SHALL PROVIDE, INSTALL AND MAINTAIN EROSION CONTROL DEVICES AS SHOWN IN THE EROSION CONTROL PLAN TO PREVENT SILTATION OF ADJACENT PROPERTY AND DRAINAGE FACILITIES PRIOR TO ANY SITE WORK. ANY SILTATION OF ADJACENT PROPERTY WILL BE REMOVED PRIOR TO FINAL ACCEPTANCE BY OWNER.
- ALL EXISTING DEBRIS WITHIN CONSTRUCTION LIMITS (ABOVE OR BELOW GROUND), CONSTRUCTION DEBRIS AND OTHER WASTE MATERIAL SHALL BE DISPOSED OF OFF-SITE BY THE CONTRACTOR IN ACCORDANCE WITH APPLICABLE REGULATORY AGENCY REQUIREMENTS.

SITE DESIGN CRITERIA

- THE OREGON 2010 STRUCTURAL SPECIALTY CODE SECTION 1613 IS USED TO DESIGN FOR EARTHQUAKE LOADS.
- THE DESIGN WIND SPEED IS 94.5 MILES PER HOUR (3-SECOND GUST) IN ACCORDANCE WITH THE OREGON 2010 STRUCTURAL SPECIALTY CODE; SEE SECTION 1609.3.1 FOR ADDITION DESIGN INFORMATION.
 - WIND EXPOSURE CATEGORY: B
- SOIL BEARING PRESSURE: 1,500 POUNDS PER SQUARE FOOT.
- ROOF SNOW LOAD IS 20 POUNDS PER SQUARE FOOT, NO DRIFTING REQUIREMENTS
- RAINFALL DESIGN IS BASED ON TWO INCHES PER HOUR.
- THE FROST DEPTH IS 12"

CONCRETE NOTES:

- ALL CONCRETE USED FOR PAVEMENT, CURB, DRAINAGE STRUCTURES AND MISCELLANEOUS CONSTRUCTION SHALL ATTAIN A MINIMUM ULTIMATE COMPRESSIVE STRENGTH OF 4000 PSI AT 28 DAYS.
- NO CONCRETE SHALL BE PLACED WITHOUT PRIOR APPROVAL OF THE ENGINEER. INSPECTOR SHALL BE ON SITE FOR ALL CONCRETE POURS. 48 HOURS PRIOR NOTICE REQUIRED BEFORE ALL CONCRETE POURS.
- ALL CONCRETE PAVEMENT JOINTS SHALL BE CLEANED AND SEALED WITH POLYURETHANE OR SILICONE POLYMER JOINT SEALER.
- CONTRACTOR TO PROVIDE A 3/4" BITUMINOUS EXPANSION JOINT MATERIAL WITH SEALER AT ALL CONCRETE EXPANSION JOINTS AND AT ABUTMENT OF CONCRETE AND OTHER MATERIALS (DRAINAGE STRUCTURES, OTHER POURED CONCRETE, ETC.).
- CONCRETE AGGREGATE SHALL CONFORM TO ODOT STANDARD SPECIFICATIONS.
- ALL REINFORCING BARS SHALL BE NEW BILLET INTERMEDIATE GRADE DEFORMED BARS CONFORMING TO A.S.T.M. A-615 AND SHALL HAVE A MINIMUM YIELD STRENGTH OF 60 KSI.
- REINFORCING BARS AND WELDED WIRE FABRIC (W.W.F.) SHALL BE TIED AND HELD AT POSITIONS SHOWN ON THE DETAILS BY USE OF STEEL WIRE BAR SUPPORTS. SUITABLE BOTTOM PLATES SHALL BE PROVIDED TO PREVENT DISPLACEMENT OF THE SUPPORT FOOT WHERE BAR SUPPORTS ARE USED ON EARTH OR AGGREGATE SUBGRADE.
- EXPOSED CONCRETE CORNERS SHALL BE CHAMFERED 3/4" UNLESS OTHERWISE NOTED.
- CONTRACTOR SHALL CONTACT ODOT OR CITY PRIOR TO BEGINNING CONSTRUCTION WITHIN STATE OR CITY RIGHT-OF-WAY. THE STATE REQUIREMENTS FOR CONSTRUCTION SIGNING SHALL BE FOLLOWED WHILE WORK IS BEING PERFORMED WITHIN STATE OR CITY R.O.W.
- BASE COURSE SHALL BE PROVIDED IN ACCORDANCE WITH ODOT STANDARD SPECIFICATIONS OR AS SPECIFIED IN THESE PLANS.

UTILITY NOTES:

- CONTRACTOR IS RESPONSIBLE FOR VERIFYING ALL UTILITIES AND NOTIFYING THE APPROPRIATE UTILITY COMPANY PRIOR TO BEGINNING CONSTRUCTION.
- THE CONTRACTOR IS SPECIFICALLY CAUTIONED THAT THE LOCATION AND/OR ELEVATION OF EXISTING UTILITIES AS SHOWN ON THESE PLANS IS BASED ON RECORDS OF THE VARIOUS UTILITY COMPANIES AND, WHERE POSSIBLE, MEASUREMENTS TAKEN IN THE FIELD. THE INFORMATION IS NOT TO BE RELIED ON AS BEING EXACT OR COMPLETE. THE CONTRACTOR MUST CALL THE APPROPRIATE UTILITY COMPANY AT LEAST 48 HOURS BEFORE ANY EXCAVATION TO REQUEST EXACT FIELD LOCATION OF THE UTILITIES. IT SHALL BE THE RESPONSIBILITY OF THE CONTRACTOR TO RELOCATE ALL EXISTING UTILITIES WHICH CONFLICT WITH THE PROPOSED IMPROVEMENTS SHOWN ON THE PLANS.
- CONTRACTOR SHALL VERIFY HORIZONTAL AND VERTICAL LOCATION OF ALL EXISTING STORM SEWER STRUCTURES, PIPES, AND ALL UTILITIES PRIOR TO CONSTRUCTION.
- CONTRACTOR IS RESPONSIBLE FOR REPAIRS OF DAMAGE TO ANY EXISTING IMPROVEMENTS DURING CONSTRUCTION, SUCH AS, BUT NOT LIMITED TO, UTILITIES, PAVEMENT, STRIPING, CURBS, ETC. REPAIRS SHALL BE EQUAL TO OR BETTER THAN EXISTING CONDITION.
- CONTRACTOR SHALL COORDINATE INSTALLATION OF UTILITIES IN SUCH A MANNER AS TO AVOID CONFLICTS AND ASSURE PROPER DEPTHS ARE ACHIEVED AS WELL AS COORDINATING WITH CITY UTILITY REQUIREMENTS AS TO LOCATIONS AND SCHEDULING FOR TIE-INS/CONNECTIONS PRIOR TO CONNECTING EXISTING FACILITIES.
- CONSTRUCTION SHALL COMPLY WITH ALL GOVERNING CODES AND BE CONSTRUCTED TO SAME.
- SEE PLANS AND SPECIFICATIONS FOR BACKFILLING AND COMPACTION REQUIREMENTS ON UTILITY TRENCHES.
- CONTRACTOR SHALL COMPLY TO THE FULLEST EXTENT WITH THE LATEST STANDARD OF OSHA DIRECTIVES OR ANY OTHER AGENCY HAVING JURISDICTION FOR EXCAVATION AND TRENCHING PROCEDURES. THE CONTRACTOR SHALL USE SUPPORT SYSTEMS, SLOPING, BENCHING, AND OTHER MEANS OF PROTECTION. THIS TO INCLUDE BUT NOT LIMITED TO, ACCESS AND EGRESS FROM ALL EXCAVATION AND TRENCHING.
- CONTRACTOR SHALL COORDINATE WITH OTHER UTILITIES AS TO ASSURE PROPER DEPTH AND PREVENT ANY CONFLICT OF UTILITIES.
- CONTRACTOR SHALL GROUT AROUND ALL PIPE ENTRANCES TO SANITARY SEWER MANHOLES AND STORM DRAIN BOXES WITH NON-SHRINKING GROUT TO ASSURE CONNECTION IS WATER TIGHT.
- WATER SERVICES, CONNECTIONS, AND INSTALLATIONS SHALL BE COMPLETED BY A OREGON LICENSED PLUMBER.

LANDSCAPING NOTES:

- THE CONTRACTOR SHALL RESTORE IN KIND EXISTING LANDSCAPING DISTURBED DUE TO CONSTRUCTION. THIS SHALL INCLUDE, BUT NOT LIMITED TO TREES, SHRUBS, FLOWERS, SOLID SOD, BEDDING MATERIAL(SOIL) AND SPRINKLER SYSTEM APPURTENANCES. DISTURBED AREAS MUST BE SEEDED AND FERTILIZED UNLESS NOTED AS SOLID SOD ON THESE PLANS. FINAL PAYMENT FOR THIS ITEM WILL BE UPON NO EROSION AND THE ESTABLISHMENT OF AN ADEQUATE STAND OF PERMANENT GRASS AS DEEMED SATISFACTORY BY THE OWNER.
- CONTRACTOR SHALL SOLID SOD ALL DISTURBED, NON-PAVED, AREAS WITHIN 7 DAYS OF LAST CONSTRUCTION AND MAINTAIN FOR AT LEAST 30 DAYS. SODDING SHALL BE IN ACCORDANCE WITH OREGON STANDARD SPECIFICATIONS FOR CONSTRUCTION, 2008 EDITION.
- CONTRACTOR SHALL APPLY FERTILIZER TO ALL SOLID SOD AREAS IN ACCORDANCE WITH THE OREGON STANDARD SPECIFICATIONS FOR CONSTRUCTION, 2008 EDITION.
- ALL TREES SHALL BE IN ACCORDANCE WITH THE CITY OF MEDFORD STANDARDS AND SHALL BE APPROVED TO BE PLACED BENEATH A POWER LINE.

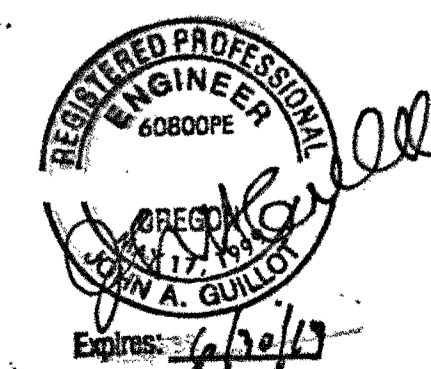

APPROVED FOR CONSTRUCTION
DATE: 10/12/11

HUNT, GUILLOT & ASSOCIATES, L.L.C.
CONSULTING ENGINEERS AND PROJECT MANAGERS
P.O. BOX 580 RUSTON, LA 71273
MODEL ID:

CONFIDENTIAL
THESE DESIGNS AND DRAWINGS ARE THE EXCLUSIVE PROPERTY OF:
HUNT, GUILLOT & ASSOCIATES, RUSTON, LA.
NO COPY OR REPRODUCTION MAY BE MADE WITHOUT WRITTEN APPROVAL.
ADROIT CONSTRUCTION
RVRTD CNG FUELING STATION
GENERAL NOTES

DESIGNED BY	PBW	8/23/11	CHECKED BY	CEH	9/14/11
DRAWN BY	PBW	8/23/11	APPROVED BY	RSO	9/14/11
PLOT AT 1:	1	DATE: 8/23/11	HGA JOB NO:	7110004	HGA ITEM NO:
SCALE	DRAWING NUMBER		REV.		
NTS	7.110004-C-200		0		

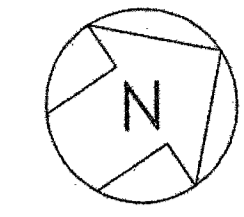

LEGEND	
	FIRE HYDRANT
	POWER POLE
	LIGHT POLE
	GUY WIRE
	ELECTRIC LINE
	PROPERTY LINE
	FIBER OPTIC CABLE
	GAS LINE
	WATER LINE
	RIGHT OF WAY
	TELEPHONE PEDESTAL
	EXISTING FENCE
	CONCRETE PAVING
	LANDSCAPING
	DEMOLITION CONCRETE AREA
	DEMOLITION ASPHALT AREA

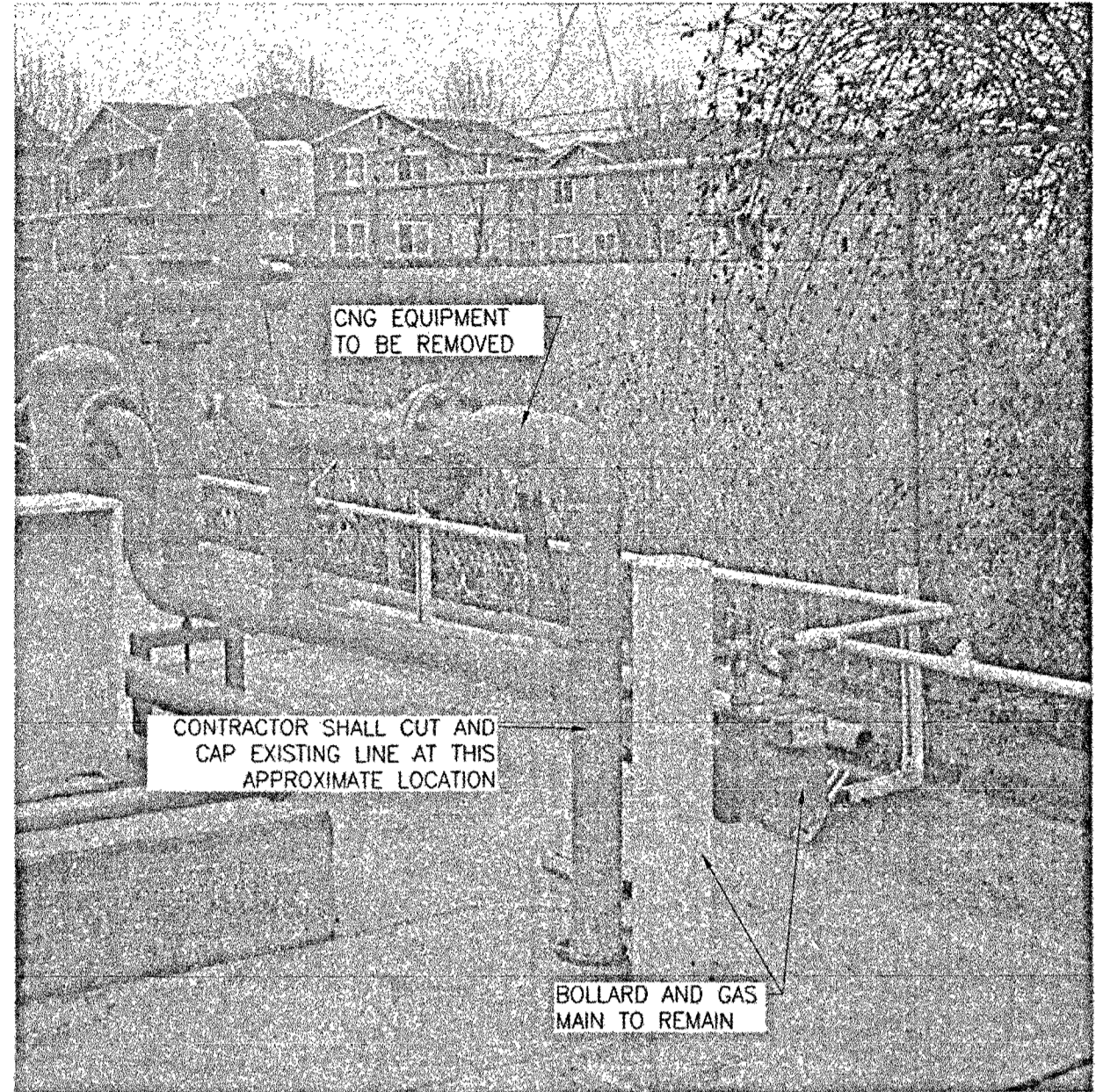

EXISTING GAS LINE & METER

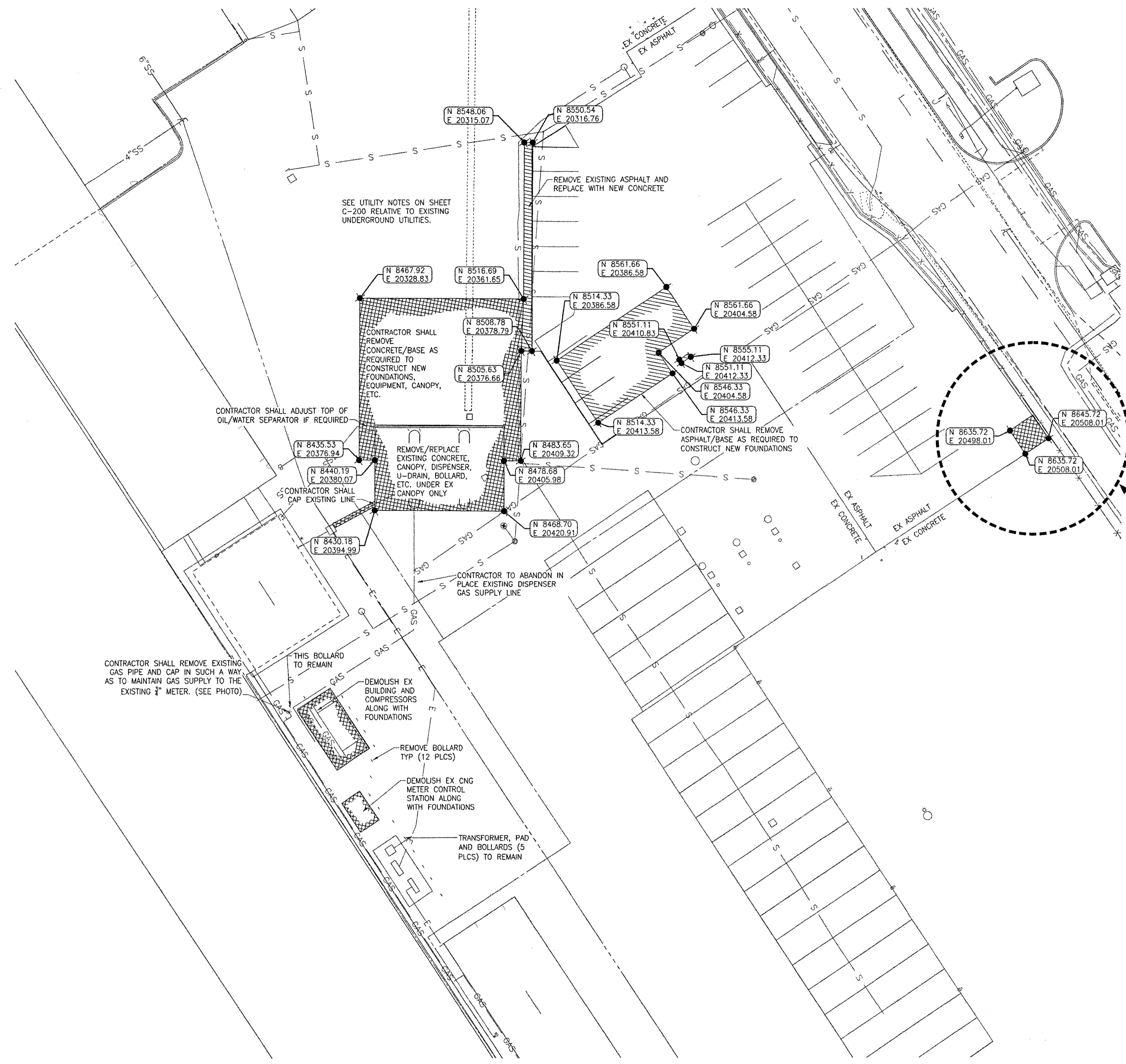

NOTES:

- CONTRACTOR SHALL BE RESPONSIBLE FOR THE DISPOSAL OF ALL DEMOLISHED MATERIAL AT AN OFF-SITE LOCATION.
- CONTRACTOR SHALL DEMOLISH AS NEEDED TO INSTALL FOUNDATIONS.
- CONTRACTOR SHALL REMOVE SURFACE AND SUBSURFACE AS NECESSARY TO ROUTE CONDUITS IN ACCORDANCE WITH MECHANICAL AND ELECTRICAL DRAWINGS. ALL TRENCHES SHALL BE BACKFILLED AND RETURNED TO EXISTING CONDITIONS UNLESS OTHERWISE NOTED.
- CONTRACTOR SHALL BE RESPONSIBLE FOR THE REMOVAL/DEMOLITION OF EXISTING PIPE WITHIN THE DEMOLITION LIMITS IN STRICT COMPLIANCE WITH ALL FEDERAL, STATE, AND LOCAL REGULATIONS.
- ALL EDGE OF DEMOLITION AREAS SHALL BE SAWCUT ONE-HALF THE DEPTH OF THE PAVEMENT BUT NOT LESS THAN FOUR (4) INCHES TO PROVIDE A CLEAN EDGE.
- NO SOIL REPORT OR AS BUILT INFORMATION WERE PROVIDED FOR THIS SITE. CONTRACTOR SHALL DETERMINE EXISTING PAVEMENT THICKNESS.

REFERENCE DRAWINGS

- 7.110004-C-003 ADROIT CONSTRUCTION RVTD CNG FUELING STATION SITE LAYOUT PLAN
- 7.110004-C-200 ADROIT CONSTRUCTION RVTD CNG FUELING STATION GENERAL NOTES



APPROVED FOR CONSTRUCTION
DATE: 10/12/11

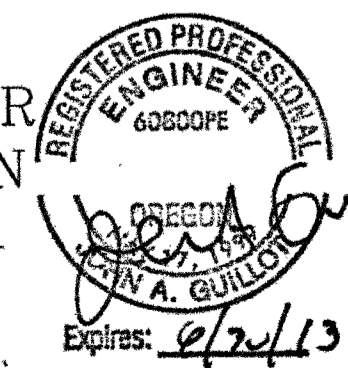

HUNT, GUILLOT & ASSOCIATES, L.L.C.
CONSULTING ENGINEERS AND PROJECT MANAGERS
P.O. BOX 580 RUSTON, LA 71273
MODEL NO.

CONFIDENTIAL
THESE DESIGNS AND DRAWINGS ARE THE EXCLUSIVE PROPERTY OF:
HUNT, GUILLOT & ASSOCIATES, RUSTON, LA.
NO COPY OR REPRODUCTION MAY BE MADE WITHOUT WRITTEN APPROVAL.

**ADROIT CONSTRUCTION
RVTD CNG FUELING STATION
DEMOLITION PLAN**

REV.	DESCRIPTION	CHK.	DATE	APP.	DATE
0	ISSUED FOR CONSTRUCTION	CEH	10/12/11	RSO	10/12/11
A	ISSUED FOR APPROVAL	CEH	9/14/11	RSO	9/14/11

DESIGNED BY	8/11/11	CHECKED BY	9/14/11
PBW		CEH	
DRAWN BY	8/11/11	APPROVED BY	9/14/11
PBW		RSO	
SCALE	DRAWING NUMBER	HGA JOB NO:	HGA ITEM NO:
1"=20'-0"	7.110004-C-002	7110004	
REV.	0		

TOPOGRAPHIC MAP OF SURVEY

Located in the Southwest One-quarter of Section 8, Township 37, Range 1 West of the Willamette Meridian, City of Medford, Jackson County, Oregon.

PREPARED FOR:

ROGUE VALLEY TRANSPORTATION DISTRICT
3200 Crater Lake Avenue
Medford, OR 97504

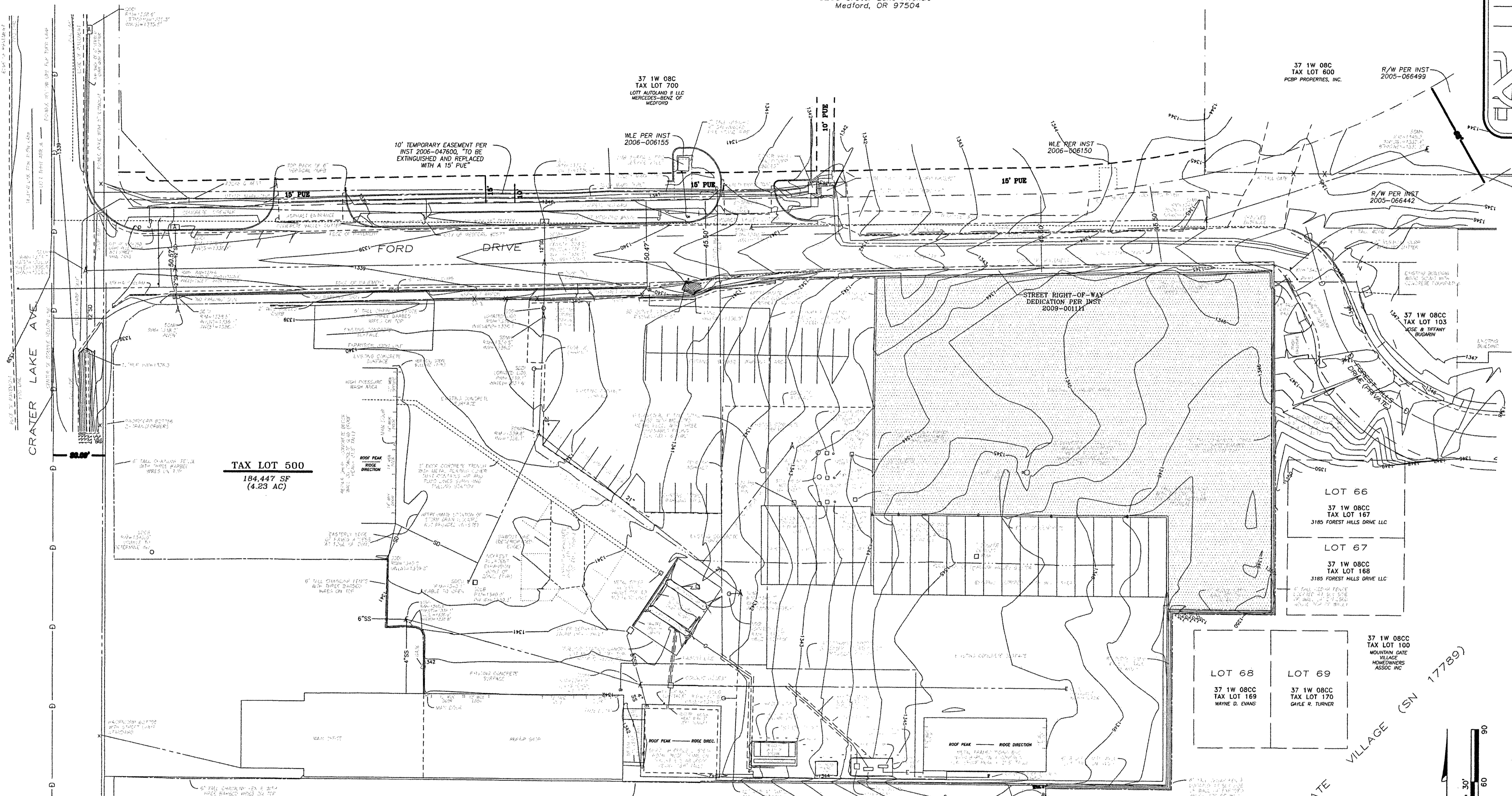
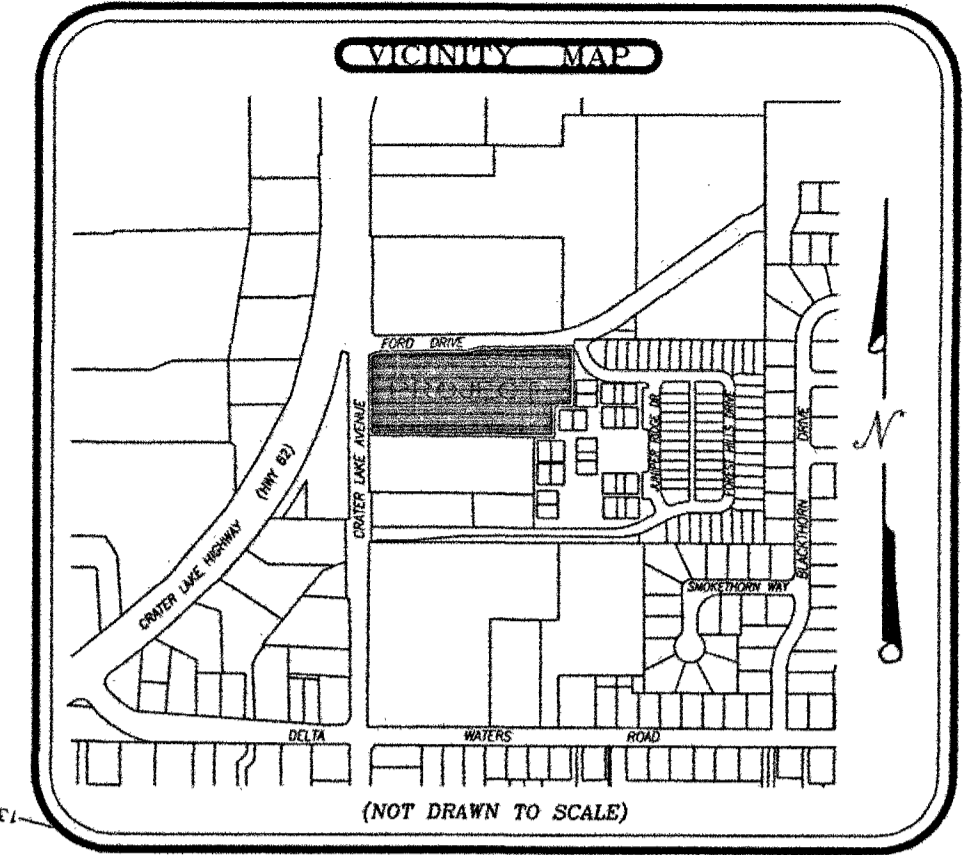

- LEGEND:**
- G- Indicates a utility marked gas line.
 - V Indicates an existing gas valve.
 - # Indicates an existing gas meter.
 - A Indicates an existing gas fiberglass sign/placard.
 - SS- Indicates a utility marked sanitary sewer line.
 - E Indicates an existing sanitary sewer manhole.
 - E Indicates an existing sanitary sewer cleanout.
 - T Indicates an existing sanitary sewer lateral.
 - SD- Indicates a utility marked storm sewer line.
 - A Indicates an existing storm sewer manhole.
 - I Indicates an existing storm sewer cleanout.
 - f Indicates an existing mail box on a concrete slab.
 - J Indicates an existing street light.
 - a Indicates an existing power pedestal.
 - i Indicates an existing power meter box.
 - x Indicates an existing power pole and guy anchor.
 - OHU- Indicates an existing overhead utility line.
 - OE- Indicates an existing overhead electric line.
 - E- Indicates a utility marked buried electric line.
 - T- Indicates a utility marked telephone line.
 - T Indicates an existing telephone pedestal.
 - W- Indicates a utility marked water line.
 - m Indicates an existing water meter.
 - Indicates an existing water valve.
 - < Indicates an existing fire hydrant.
 - Δ Indicates an existing irrigation water spigot.
 - ⊙ Indicates an existing lawn irrigation box.
 - D Indicates a deciduous tree with drip-line diameter drawn to scale.
 - ND Indicates a non-deciduous tree with drip-line diameter drawn to scale.
 - w=1000' Indicates the elevation at the top of the valve nut for a water valve.
 - n, ne, nw Indicates a general direction: northerly, northeasterly, northwesterly, etcetera.
 - CLF Indicates a chain link fence.
 - WBF Indicates a wood board fence.
 - ep Indicates the edge of a paved street.
 - ttc Indicates the top back of a 6" vertical curb.
 - Indicates centerline of an existing fence line.

PROJECT NOTES:

Contour Interval: 0.5 foot
Index Contour Interval: 1 foot

All existing underground utilities, as depicted hereon, were located with reasonable accuracy, as marked on the ground by affected agencies and utility companies. Oregon Administrative Rules Chapter 552, Division 1, Definitions, 95-001-0010 (12), states: "reasonable accuracy" means location within 24 inches of the outside lateral dimensions of both sides of an underground facility.

Property herein, in accordance with the public records report provided by AmeriTitle, may be subject to the following matters of record:

Regulations, including levies, assessments, water and irrigation rights and easements for ditches and canals of the Rogue River Valley Irrigation District.

The rights of the public in and to the subject tract of land hereof, lying within the limits of public roads, streets and highway.

The terms, provisions and conditions, including but not limited to maintenance provisions, dealing mainly with public sewer lines, per the Agreement Granting Easements in Instrument No. 75-07946 of the Official Records of Jackson County, Oregon; report notes as being appurtenant to subject tract.

The Terms and Provisions of a Mortgage recorded as Instrument No. 82-10870 and a Promissory Note per Instrument No. 83-03704 of the Official Records of Jackson County, Oregon.

Underground 10-foot wide easement granted to Pacific Power and Light Co. per Instrument No. 87-22543 and to PacifiCorp per Instrument No. 94-34638, both of the Official Records of Jackson County, Oregon. The location of said easement was not able to be accurately placed hereon, further research and coordination with PacifiCorp would be necessary to locate.

Appurtenant easement for sewer lines per Instrument No. 85-10144 of the Official Records of Jackson County, Oregon.

BASIS OF SURVEY:

Basis of Bearings: Geodetic North based on WGS 84 (World Geodetic System 1984), via GPS (Global Positioning System) observations. Basis applied to the West line of Section 8 and centerline of Crater Lake Avenue, as depicted hereon.

Basis of Elevations: City of Medford vertical datum referenced from City of Medford Bench Mark Number A-231, having a published elevation of 1326.224 feet, and being a found brass disk in the center of a headwall of a box culvert under Crater Lake Avenue, being approximately 18 feet southerly of power pole number PacifiCorp 080500 and approximately 250 feet northerly of the One-quarter Corner common to Sections 7 and 8, Township 37 South, Range 1 West of the Willamette Meridian, in the City of Medford, Jackson County, Oregon.

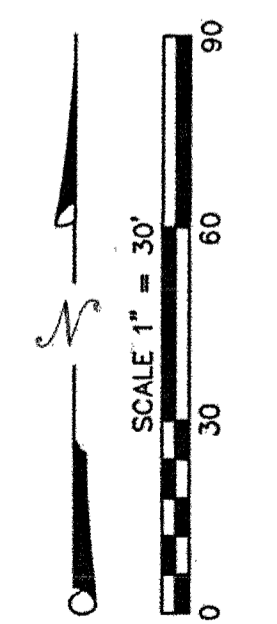

- ABBREVIATIONS:**
- CMP= Indicates an existing corrugated metal pipe.
 - PVC= Indicates an existing polyurethane vinyl chaired pipe.
 - RCP= Indicates an existing re-enforced concrete pipe.
 - SSCO= Indicates an existing sanitary sewer cleanout.
 - SSMH= Indicates an existing sanitary sewer manhole.
 - SDCO= Indicates an existing storm sewer cleanout.
 - SDCI= Indicates an existing storm sewer curb inlet.
 - WV= Indicates an existing water valve.

PREPARED BY: Neathamer Surveying, Inc.
3132 St. Suite 110
P.O. Box 1584
Medford, Oregon 97501
Phone (541) 732-2869
FAX (541) 732-1382

PLOT DATE: May 6, 2009 **PROJECT NUMBER:** 09020
Sheet 1 of 1 © CEN

THIS SURVEY DRAWING WAS PROVIDED TO HUNT, GUILLOT, AND ASSOCIATES BY ROGUE VALLEY TRANSPORTATION DISTRICT. IT IS PROVIDED FOR REFERENCE SINCE IT WAS THE BASIS OF HUNT, GUILLOT, AND ASSOCIATES DESIGN.

PLANS FOR RVTD CNG FUELING STATION FOR ADROIT CONSTRUCTION

OCTOBER 2011

NOTE:
ITEMS NOT ADDRESSED IN THE SPECIFICATIONS SPECIFIC TO THIS PROJECT SHALL BE GOVERNED BY THE CITY OF MEDFORD'S STANDARD SPECIFICATIONS. ITEMS NOT ADDRESSED IN THE CITY'S SPECIFICATIONS SHALL BE GOVERNED BY THE 2008 EDITION OF THE OREGON STANDARD SPECIFICATIONS FOR CONSTRUCTION.



PREPARED BY:
HUNT, GUILLOT & ASSOCIATES, L.L.C.
CONSULTING ENGINEERS AND PROJECT MANAGERS
P.O. BOX 580
RUSTON, LA 71273

APPROVED FOR
CONSTRUCTION
DATE: 10/12/11

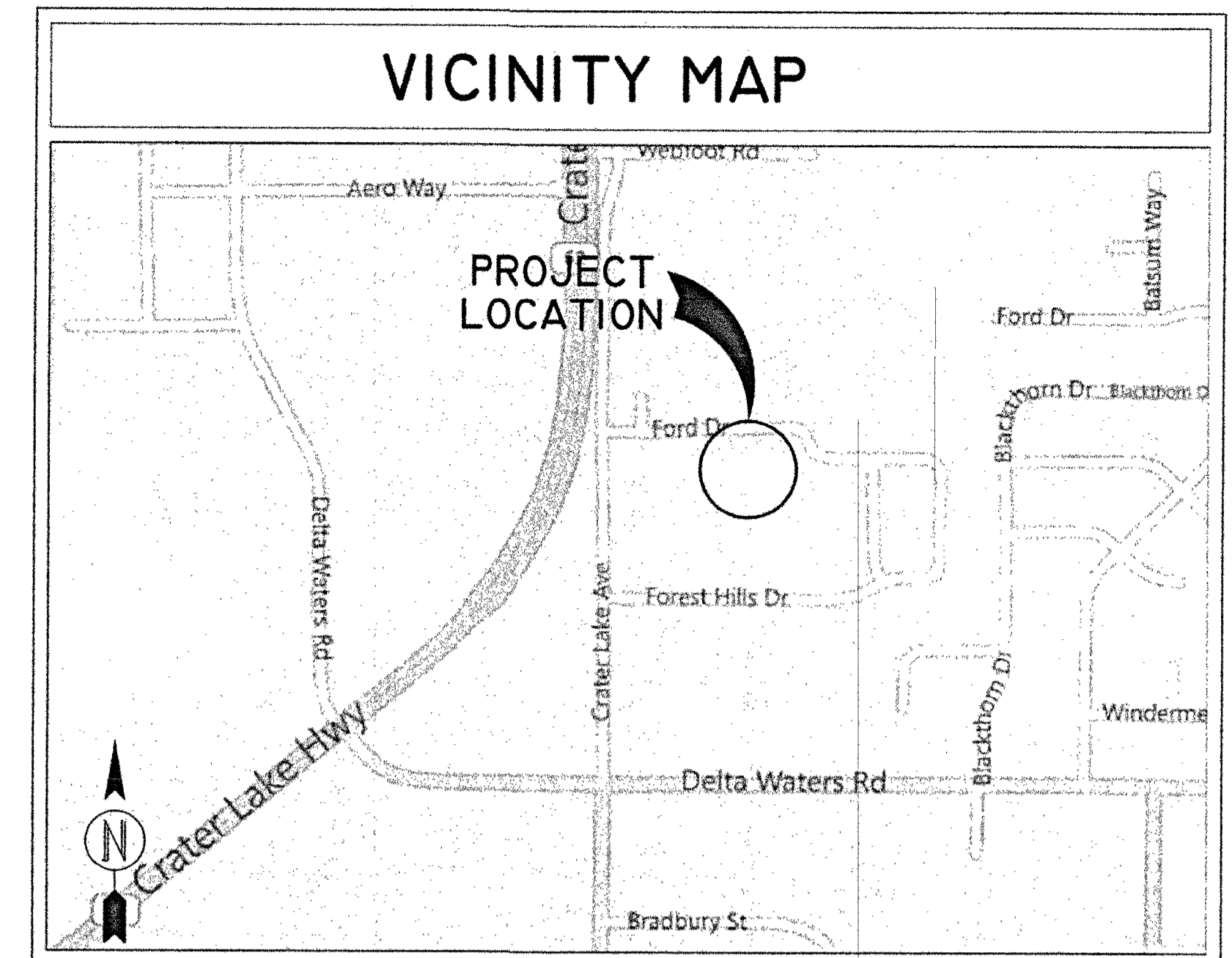

ROGUE VALLEY TRANSPORTATION DISTRICT APPROVAL	
APPROVED BY _____	DATE _____
PRESIDENT _____	

SHEET INDEX	
SHEET NO.	DESCRIPTION
T-001	TITLE SHEET
C-001	TOPOGRAPHIC SURVEY
C-002	DEMOLITION PLAN
C-003	SITE LAYOUT PLAN
C-004	PAVING, GRADING & DRAINAGE PLAN
C-100	SECTIONS AND DETAILS SHEET 1
C-101	SECTIONS AND DETAILS SHEET 2
C-200	GENERAL NOTES
C-201	EROSION CONTROL DETAILS
C-202	FENCE DETAILS
M-001	SITE LAYOUT
M-002	EQUIPMENT LAYOUT
M-003	DISPENSER LAYOUT
M-004	PIPE SPECIFICATIONS
E-001	ONE-LINE/GENERAL NOTES
E-002	ELECTRICAL SITE PLAN
E-003	ELECTRICAL DETAILS
STD-F-001	ANCHOR BOLT DETAILS

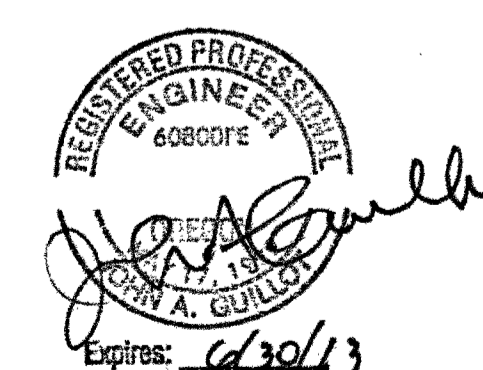

HUNT, GUILLOT & ASSOCIATES, L.L.C.
CONSULTING ENGINEERS AND PROJECT MANAGERS
P.O. BOX 580 RUSTON, LA 71273
MODEL #:

CONFIDENTIAL
THESE DESIGNS AND DRAWINGS ARE THE EXCLUSIVE PROPERTY OF:
HUNT, GUILLOT & ASSOCIATES, RUSTON, LA.
NO COPY OR REPRODUCTION MAY BE MADE WITHOUT WRITTEN APPROVAL.

**ADROIT CONSTRUCTION
RVTD CNG FUELING STATION
TITLE SHEET**

DESIGNED BY	PBW	8/23/11	CHECKED BY	CEH	9/14/11
DRAWN BY	PBW	8/23/11	APPROVED BY	RSO	9/14/11
PLOT AT 1: 1		DATE: 8/23/11	HGA JOB NO: 7.110004	HGA ITEM NO:	
SCALE	DRAWING NUMBER		REV.		
1"=150'-0"	7.110004-T-001		0		

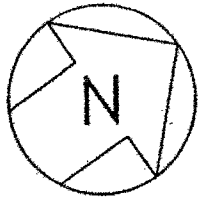

LEGEND	
	FIRE HYDRANT
	POWER POLE
	LIGHT POLE
	GUY WIRE
	ELECTRIC LINE
	PROPERTY LINE
	FIBER OPTIC CABLE
	GAS LINE
	WATER LINE
	RIGHT OF WAY
	TELEPHONE PEDESTAL
	EXISTING FENCE
	CONCRETE PAVING
	ASPHALT PAVING
	LANDSCAPING
	FLOW DIRECTION ARROW
	EXPANSION JOINT
	DUMMY JOINT
	THICKENED EDGE

NOTES:

- CONTRACTOR SHALL INSTALL CANOPY FOUNDATION IN ACCORDANCE WITH CANOPY VENDOR INSTRUCTIONS AND/OR DRAWINGS.
- CANOPY DOWNSPOUT SHALL BE FIELD ROUTED TO CONNECT TO STORM SYSTEM.
- FOUNDATION DESIGN IS BASED ON ASSUMED MINIMUM SOIL BEARING CAPACITIES AS PROVIDED BY THE CITY OF MEDFORD BUILDING SAFETY DEPARTMENT'S INFORMATION HANDOUT. IF THE SOIL BEARING CAPACITY IS FOUND TO BE LESS THAN THE ASSUMED MINIMUM, CONTRACTOR SHALL NOTIFY THE ENGINEER IMMEDIATELY.
- U-DRAIN CONSTRUCTION DRAWINGS SHALL BE SUBMITTED FOR APPROVAL PRIOR TO INSTALLATION. U-DRAIN SHALL BE INSTALLED ACCORDING TO MANUFACTURER'S RECOMMENDATIONS IN SUCH A WAY AS TO SECURE TO SURROUNDING PAVEMENT. U-DRAIN SHALL ALSO BE TRAFFIC RATED FOR CITY BUSES AND ADA COMPLIANT.
- PER CITY OF MEDFORD RECORDS, DETENTION FOR THIS SITE EXISTS. DRAINAGE FOR THIS AREA FLOWS INTO STORM DRAIN AND EXITS THROUGH A 21" DIAMETER STORM DRAIN TO THE WEST. THIS OUTFLOW HAS A DETENTION OUTFALL SYSTEM. PER STORM WATER ORDINANCE, STORM WATER QUALITY SHALL BE REQUIRED FOR THE ADDITIONAL CANOPY AND DISTURBED AREAS.
- THIS PROJECT REQUIRES 2817 SQUARE FEET OF DRAINAGE TO BE FILTERED. SEE PLAN FOR PROPOSED DRAINAGE AREA TO BE FILTERED.
- CONTRACTOR SHALL FIELD GRADE ALL CONCRETE AS NECESSARY TO DRAIN.

REFERENCE DRAWINGS

- 7.110004-C-003 ADROIT CONSTRUCTION RVTD CNG FUELING STATION SITE LAYOUT PLAN
- 7.110004-C-200 ADROIT CONSTRUCTION RVTD CNG FUELING STATION GENERAL NOTES

APPROVED FOR CONSTRUCTION
DATE: 10/12/11

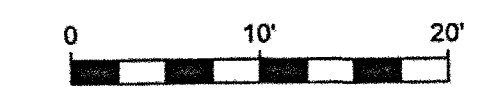

HUNT, GUILLOT & ASSOCIATES, L.L.C.
CONSULTING ENGINEERS AND PROJECT MANAGERS
P.O. BOX 580 RUSTON, LA 71273

CONFIDENTIAL
THESE DESIGNS AND DRAWINGS ARE THE EXCLUSIVE PROPERTY OF:
HUNT, GUILLOT & ASSOCIATES, RUSTON, LA.
NO COPY OR REPRODUCTION MAY BE MADE WITHOUT WRITTEN APPROVAL.

ADROIT CONSTRUCTION RVTD CNG FUELING STATION PAVING, GRADING & DRAINAGE PLAN

DESIGNED BY	PBW	8/23/11	CHECKED BY	CEH	9/14/11
DRAWN BY	PBW	8/23/11	APPROVED BY	RO	9/14/11
PLOT AT 1:1	DATE	8/23/11	HGA JOB NO:	7110004	HGA ITEM NO:
SCALE	1"=10'-0"	DRAWING NUMBER	7.110004-C-004	REV.	0

DETENTION AREA CALCULATIONS	
LOCATION	AREA (SQ. FT.)
EXISTING CANOPY	1413
PROPOSED CANOPY	2500
COMPRESSOR PAD	217
TANK PAD	197
DRYER PAD	60
CMU WALL	80
GAS METER	6
TRANSFORMER VAULT	100
EXISTING CNG EQUIPMENT PAD	366
EXISTING CNG METER CONTROL PAD	98
CONCRETE EXTENSION	225
TRENCHING	381
TOTAL	2817

REV.	DESCRIPTION	CHK.	DATE	APP.	DATE
0	ISSUED FOR CONSTRUCTION	CEH	10/12/11	RSO	10/12/11
A	ISSUED FOR APPROVAL	CEH	9/14/11	RSO	9/14/11

